

Cal. VD76A

ϕ 23.70 mm

H 3.45 mm

Item	Version No.
Specification - 1	Version 4
Specification - 2	Version 1
Appearance	Version 5
Casing	Version 7
Hand Fitting	Version 4
Hand Setting Stem	Version 4
Dial	Version 2
Casing Ring	Version 1
Assembly Plan	Version 6
Hands	Version 2



MOVEMENT SPECIFICATION - 1

CAL.VD76A 10 1/2 Ligne Quartz Movement Two Hands with 3 Eyes (Day/Date/Small second indicator)

1. MOVEMENT DIMENSIONS

- Outside diameter ϕ 23.70 22.60mm (12H~6H) x 22.60mm (3H~9H)
- Casing diameter ϕ 23.30 22.10mm (12H~6H) x 21.40mm (3H~9H)
- Total height 3.45 mm

2. TIME STANDARD

- Type of quartz oscillator Tuning fork
- Frequency of quartz oscillator 32,768 H Z
- Accuracy Monthly rate: Less than 20 seconds per month at normal temperature range
- Regulation device Nil
- Regulation hands unbalance Minute : Less than 0.6 μ N·m (60mg·mm)
Hour : Less than 0.6 μ N·m (60mg·mm)
- Small hands unbalance Less than 0.05 μ N·m (5mg·mm)
for day, date, small second hands

3. BATTERY

- Type Silver oxide battery
- Size ϕ 6.8 x t 2.6 (mm)
- Nominal voltage 1.55V
- Battery life Approx. 3 years
- Recommended battery SR626SW (SEIZAIKEN)

4. STEPPING MOTOR

- Type Two pole stepping motor
- Step 180° every second

5. JEWEL

0 jewel

6. ANTIMAGNETISM

(direct current magnetic field)

\geq 1600 A / m

7. SHOCK RESISTANCE

On equal level with general quartz movement

8. OPERATING TEMPERATURE RANGE

From - 5°C to + 50°C

9. TEST OF ACCURACY

- Equipment to be used SEIKO Quartz Tester QT - 99
Greiner Quartz Timer - C
Watch Q-Tester 4000
- Duration of measurement 10 seconds
- Microphone to be used Electromagnetic detection type

*** All specifications are subject to change without notice.**

Movement Specification - 2

CAL. VD76A

OPERATION

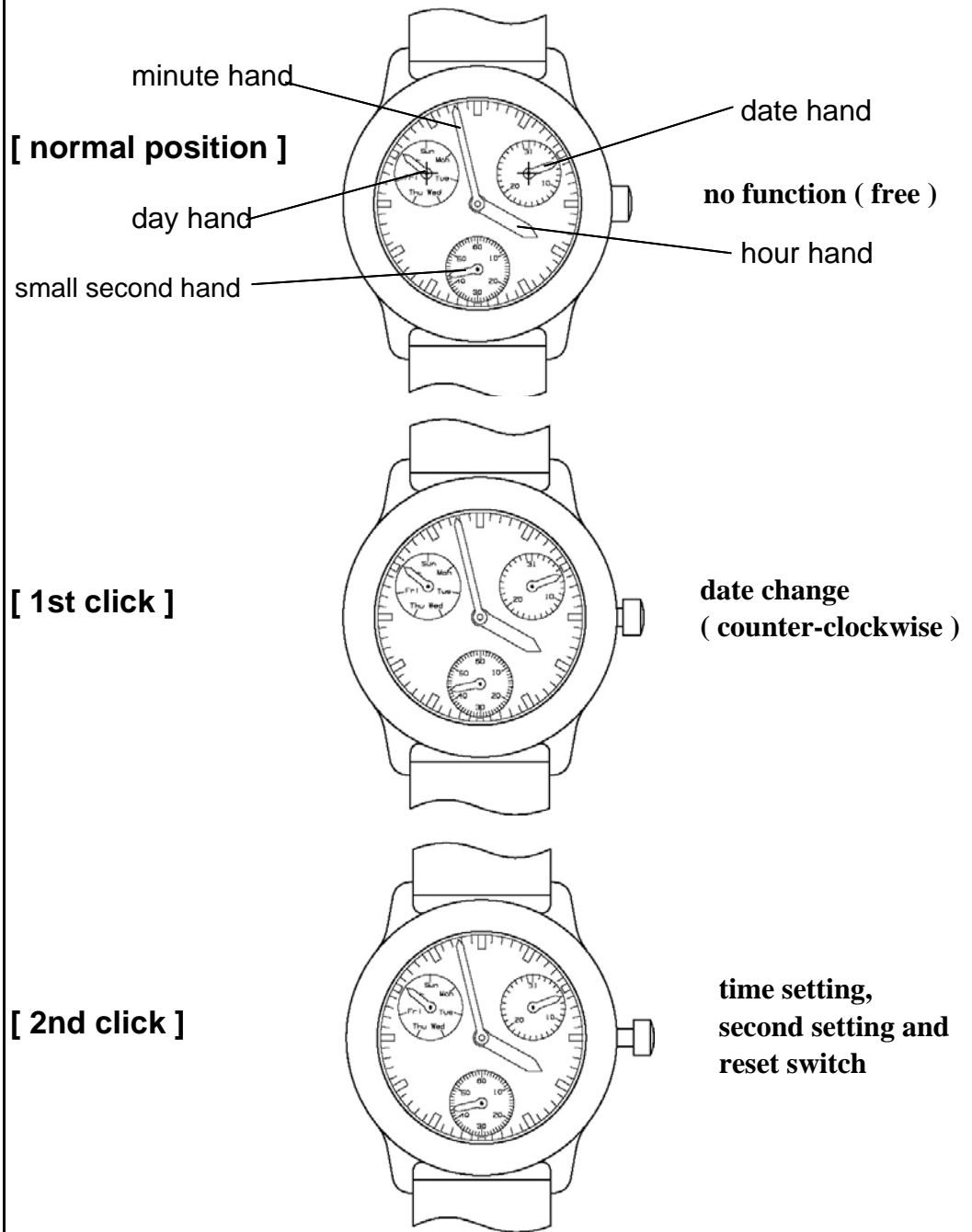

Version 1

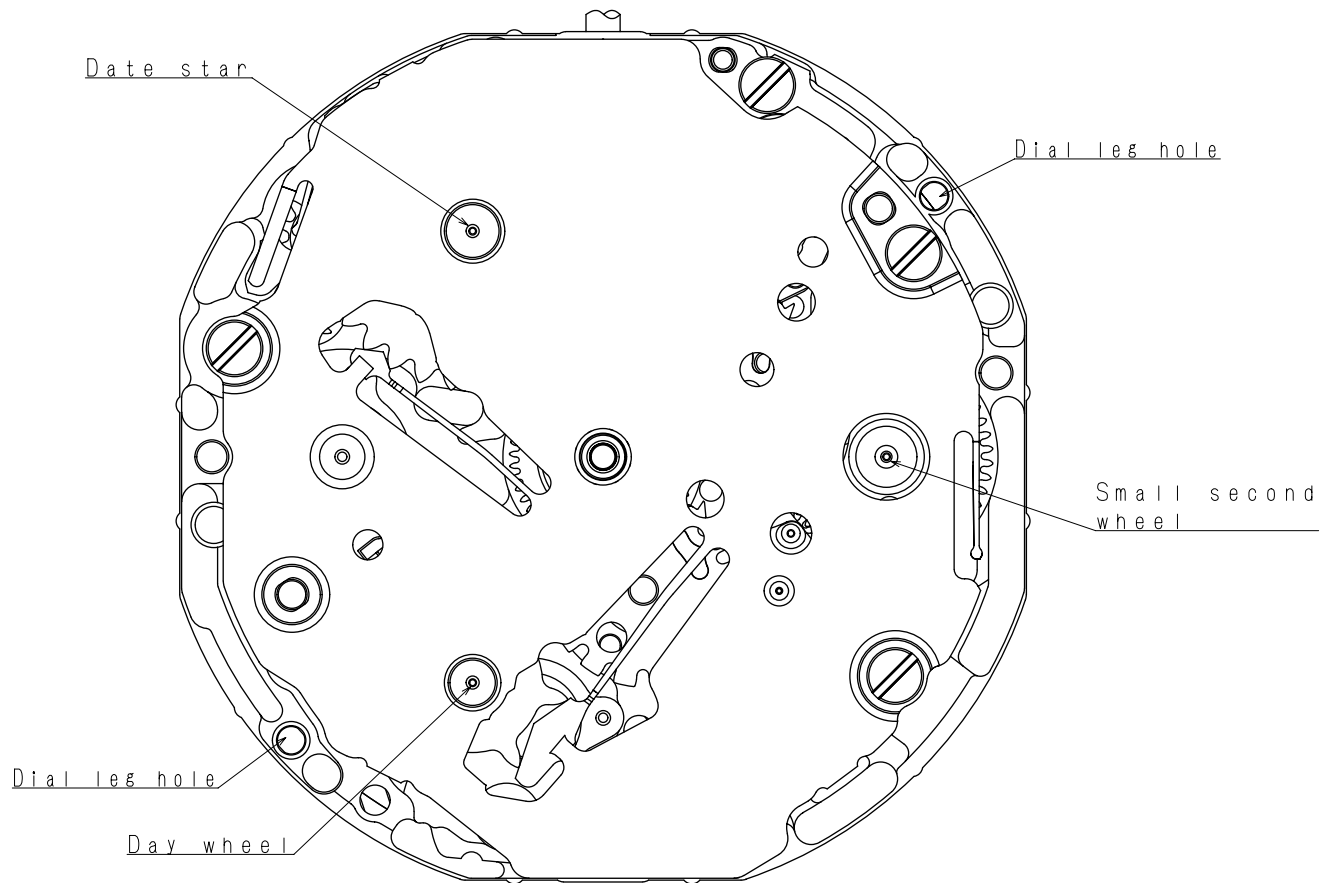
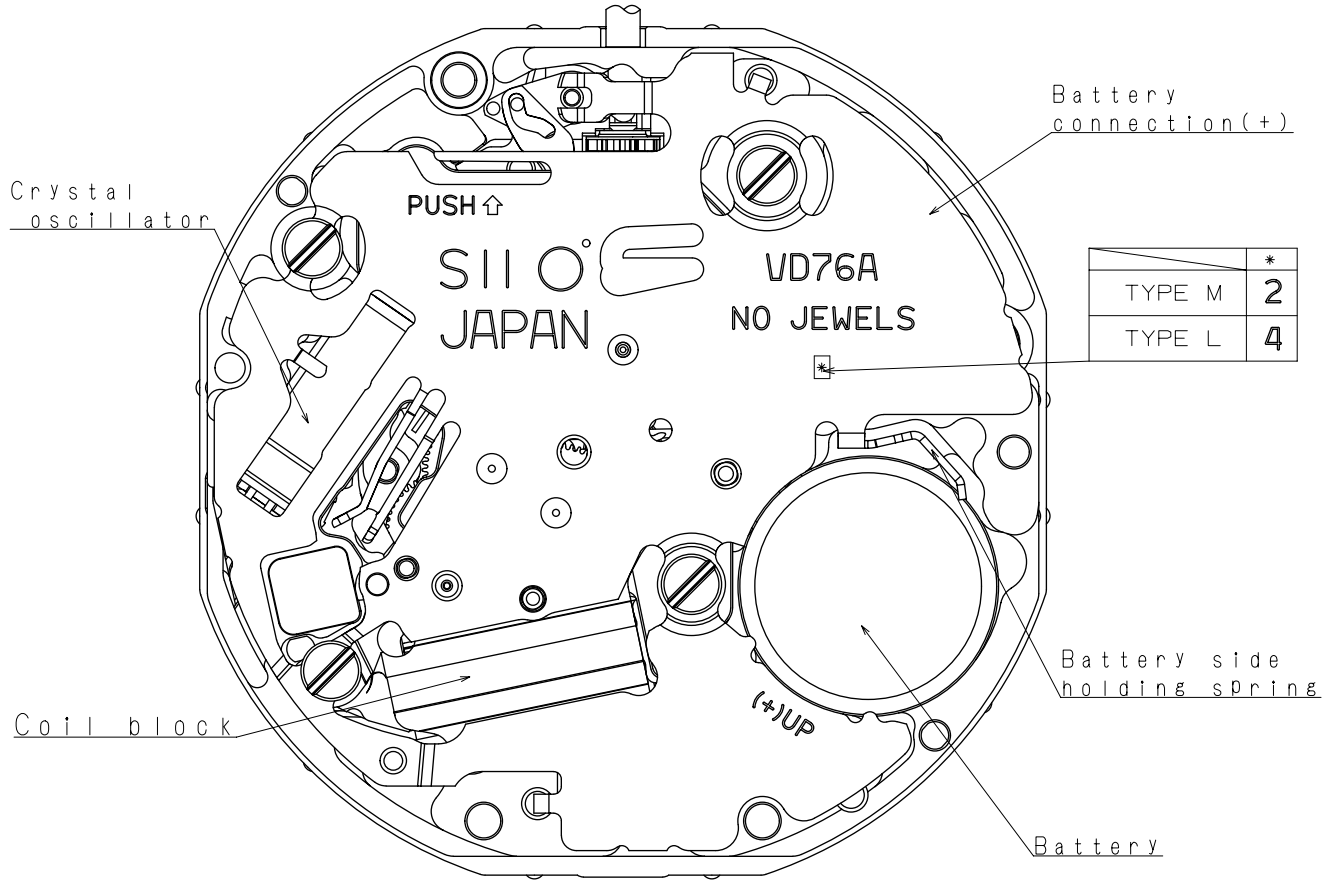

Scale : 5/1
Unit : 1=1/100mm

Version:5

* First pull out stroke 45
** Second pull out stroke 39.9

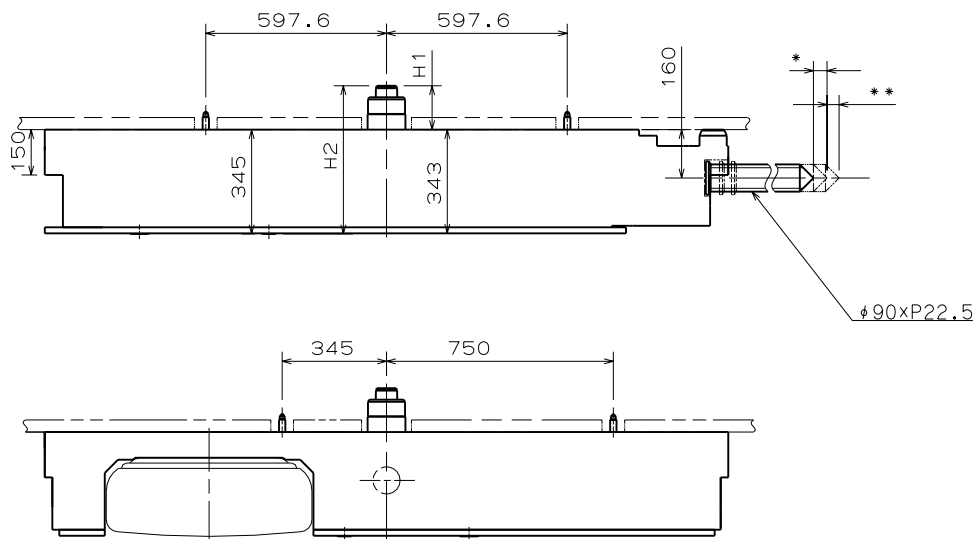

Center post 中心柱位		Type M 一般針高	Type L 高針
Maximum height from main plate surface 與機芯平面之最大高度	H1	150	230
Total height incl. movement 機芯總高度	H2	495	575

Hand Setting Stem	TYPE A	TYPE B
L1	2436	3012

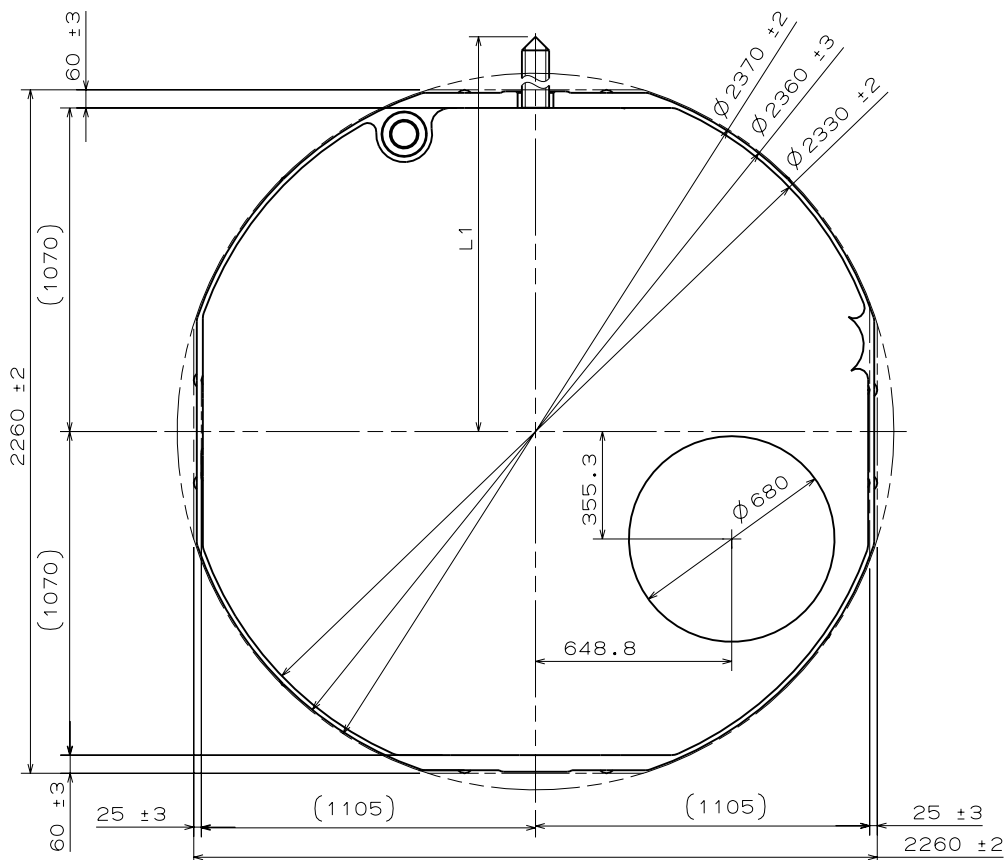

Scale : 4/1

Unit : 1=1/100mm

Version : 7

Hand Fitting

Cal. VD76A

- *Hour hand unbalance $\leq 0.6 \mu\text{N}\cdot\text{m}$ (60mg·mm)
- *Minute hand unbalance $\leq 0.6 \mu\text{N}\cdot\text{m}$ (60mg·mm)
- *Small second hand unbalance $\leq 0.05 \mu\text{N}\cdot\text{m}$ (5mg·mm)
- *Day hand unbalance $\leq 0.05 \mu\text{N}\cdot\text{m}$ (5mg·mm)
- *Date hand unbalance $\leq 0.05 \mu\text{N}\cdot\text{m}$ (5mg·mm)

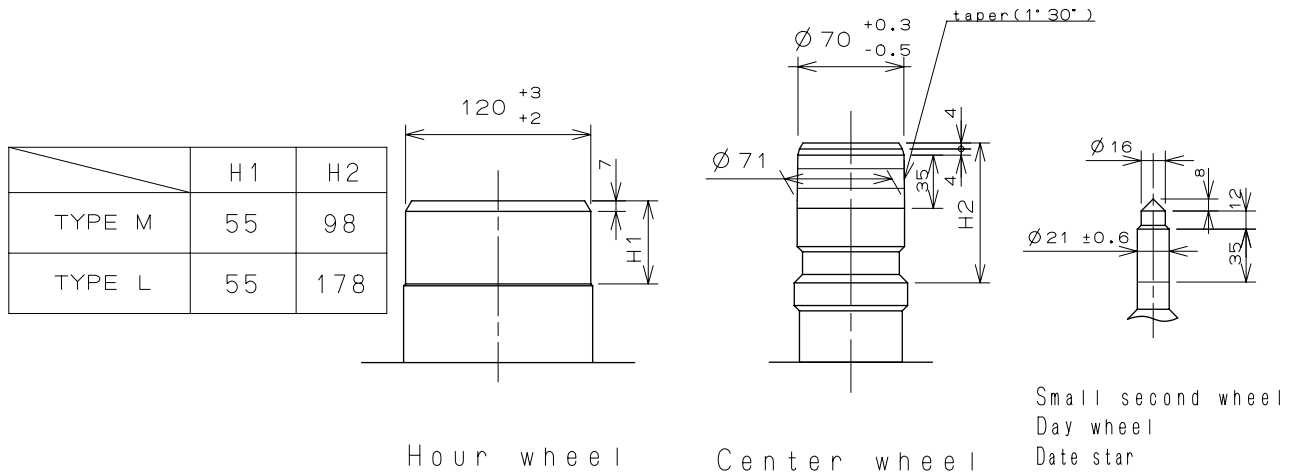

Part name	Part No.	
	TYPE M	TYPE L
Hour wheel	0273 1690	0273 0350
Center wheel	0221 0690	0221 0760
Small second wheel	0240 1690	0240 0150
Day wheel	1019 1690	1019 0400
Date star	0970 1690	0970 0370

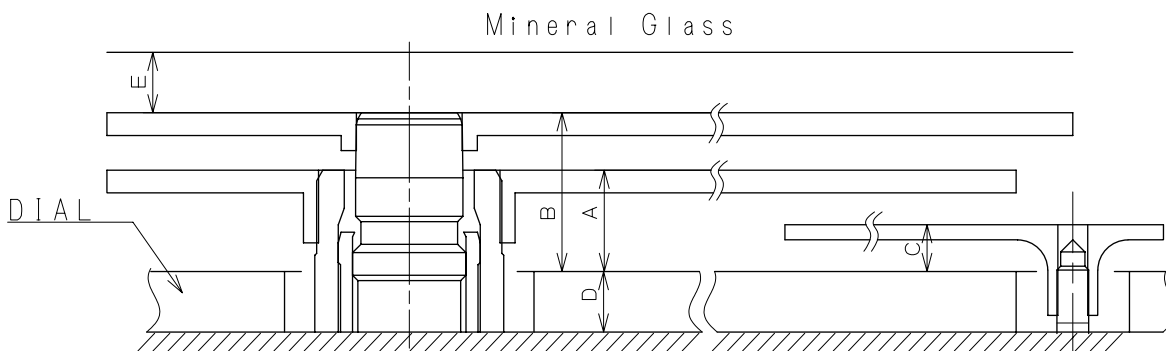

	A	B	C	D	E
TYPE M	72	110	31	40	35
TYPE L	95	145	41	85	40

Scale : 20/1

Version : 4

Unit : 1=1/100mm

Hand Fitting

Cal. VD76A

- *Hour hand unbalance $\leq 0.6 \mu\text{N}\cdot\text{m}$ (60mg·mm)
- *Minute hand unbalance $\leq 0.6 \mu\text{N}\cdot\text{m}$ (60mg·mm)
- *Small second hand unbalance $\leq 0.05 \mu\text{N}\cdot\text{m}$ (5mg·mm)
- *Day hand unbalance $\leq 0.05 \mu\text{N}\cdot\text{m}$ (5mg·mm)
- *Date hand unbalance $\leq 0.05 \mu\text{N}\cdot\text{m}$ (5mg·mm)

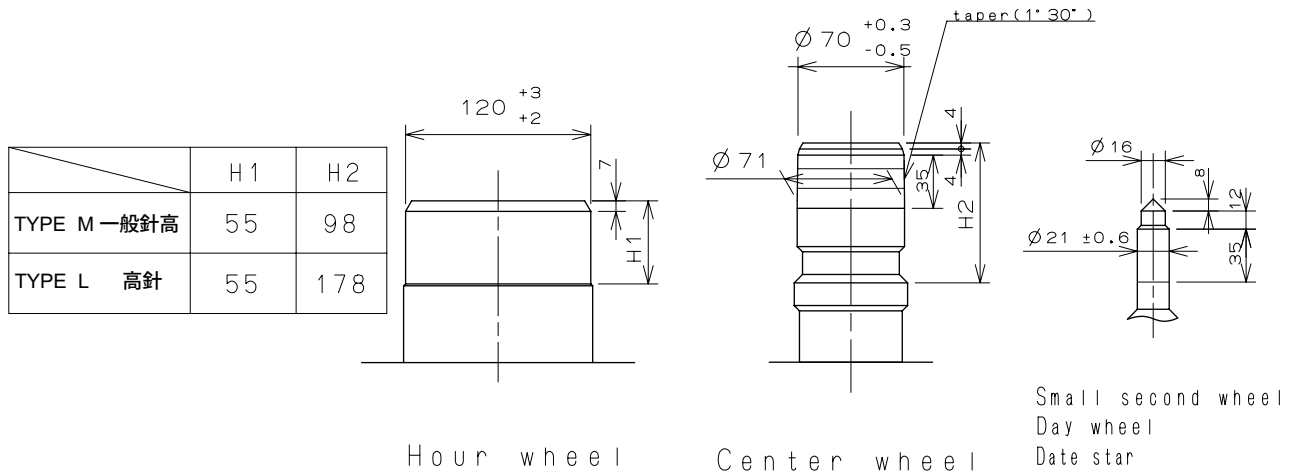

Part name	Part No.	
	TYPE M 一般針高	TYPE L 高針
Hour wheel 時針輪	0273 1690	0273 0350
Center wheel 分針輪	0221 0690	0221 0760
Small second wheel 小秒針輪	0240 1690	0240 0150
Day wheel 星期針輪	1019 1690	1019 0400
Date star 日曆針輪	0970 1690	0970 0370

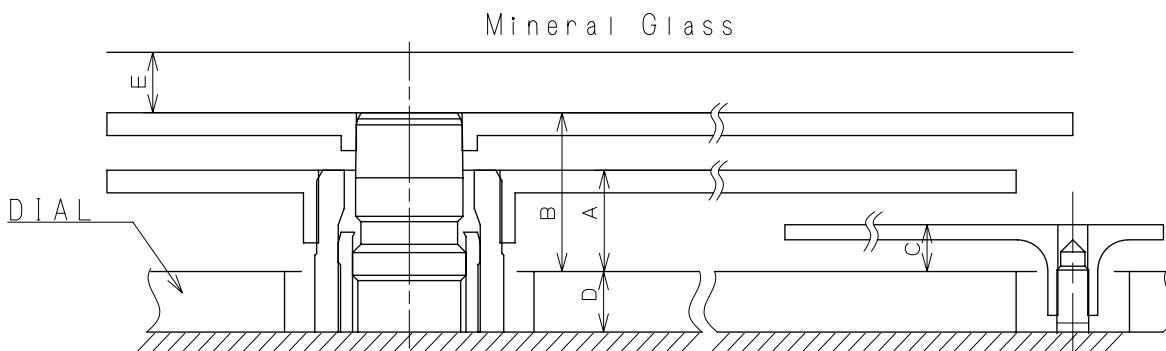

	A	B	C	D	E
TYPE M 一般針高	72	110	31	40	35
TYPE L 高針	95	145	41	85	40

Scale : 20/1

Version : 4

Unit : 1=1/100mm

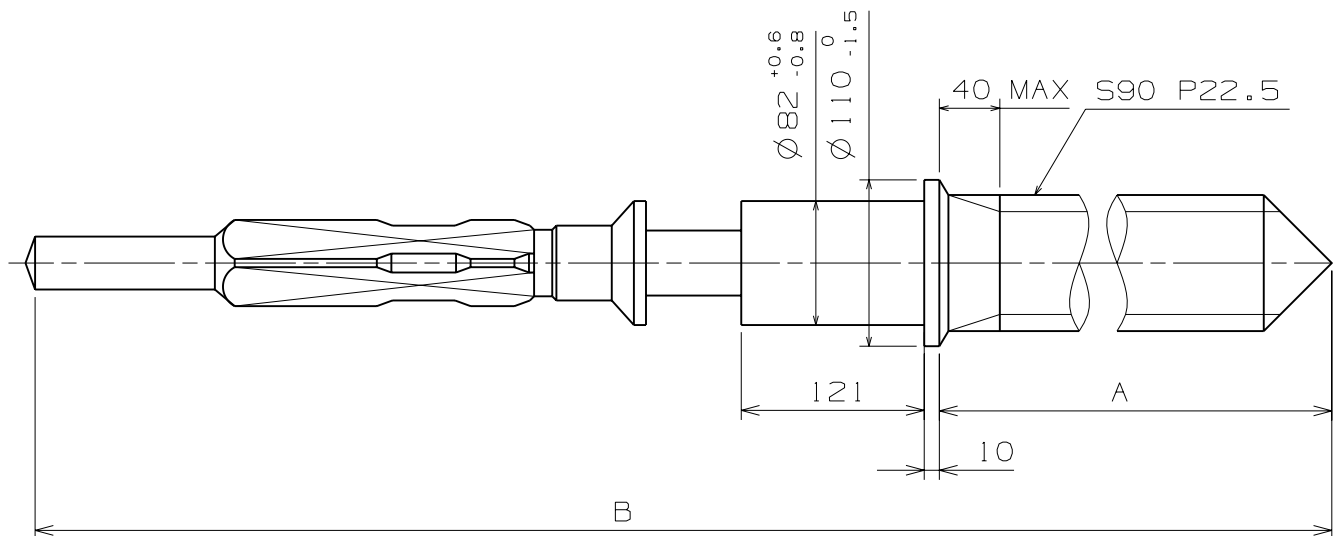

	Part. No.	A	B
TYPE A	0351 1770	1371	1969
TYPE B	0351 1220	1947	2545

Scale : 20/1

Unit : 1=1/100mm

Version:4

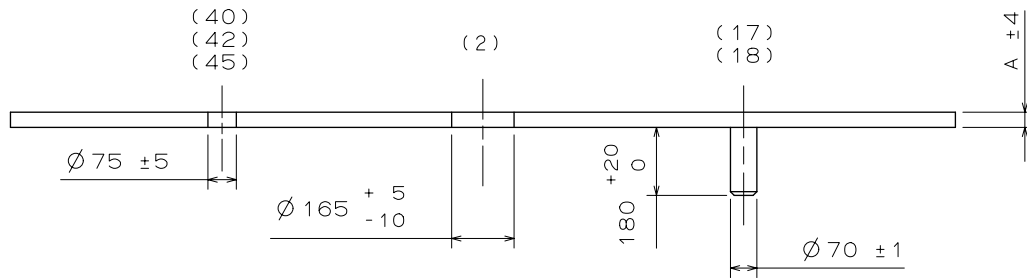
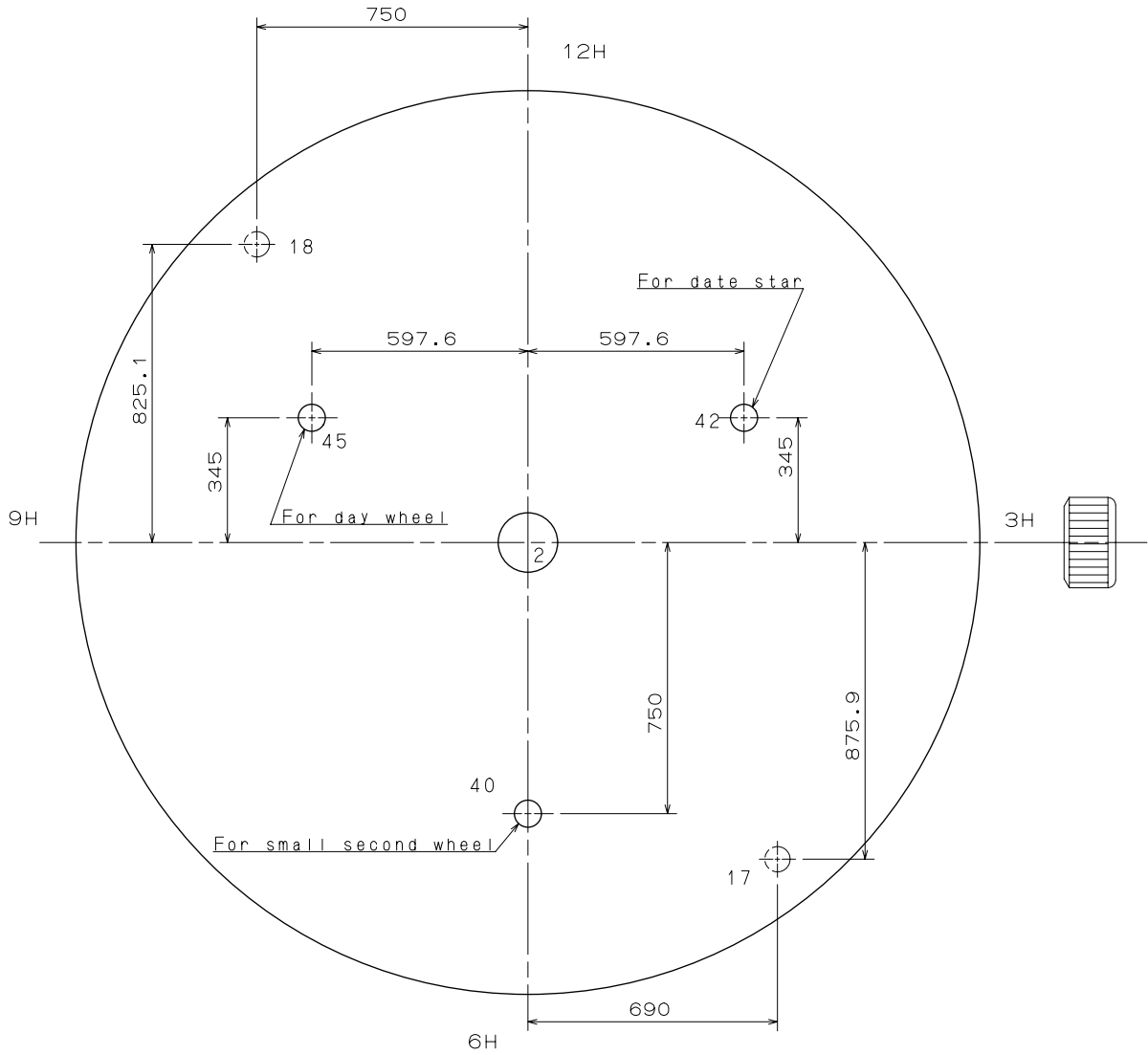

	TYPE M	TYPE L
A	40	85

Scale : 5/1
Unit : 1=1/100mm

Version:2

Casing Ring

Cal. VD76A

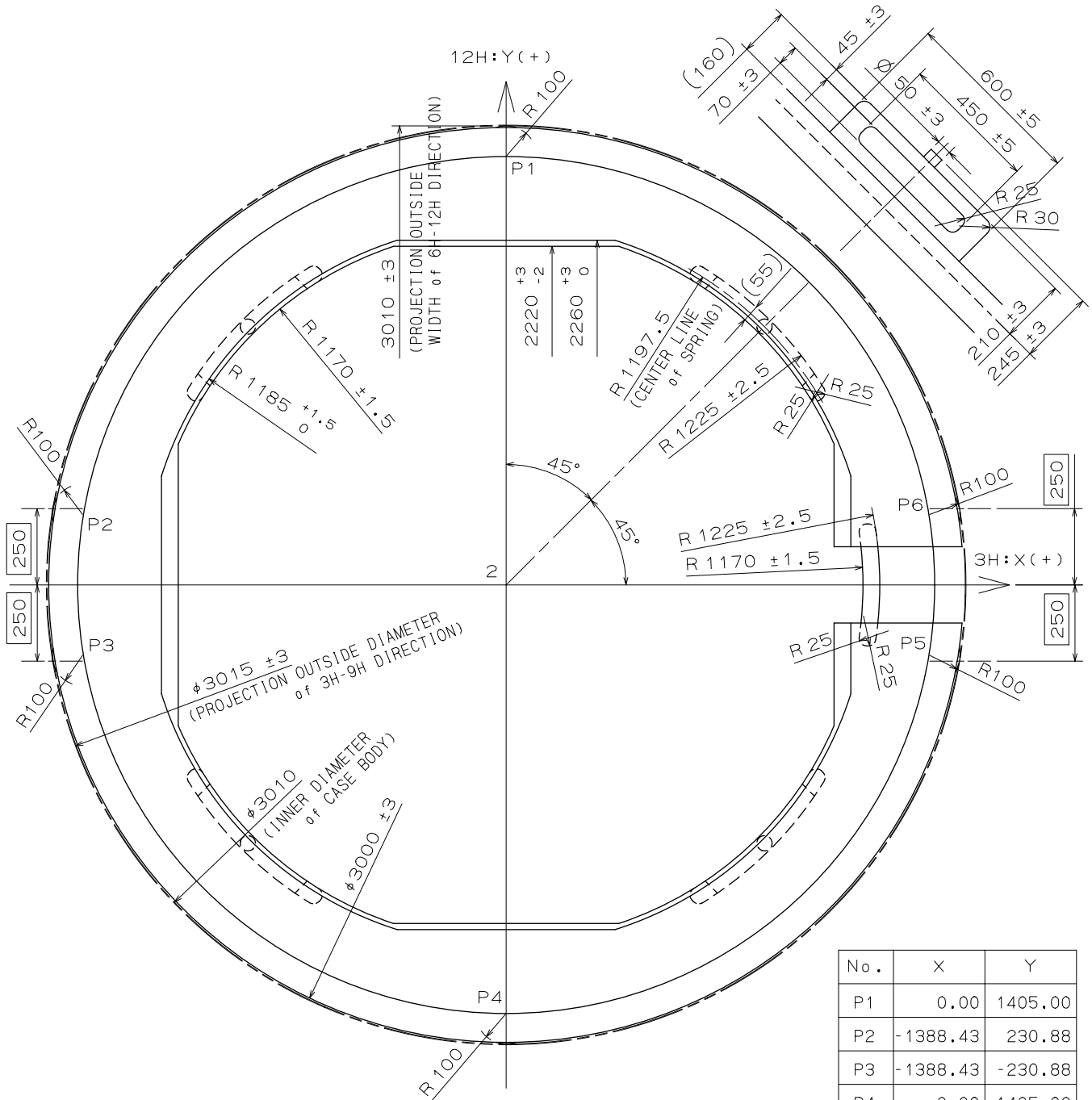

No.	X	Y
P1	0.00	1405.00
P2	-1388.43	230.88
P3	-1388.43	-230.88
P4	0.00	-1405.00
P5	1388.43	-230.88
P6	1388.43	230.88

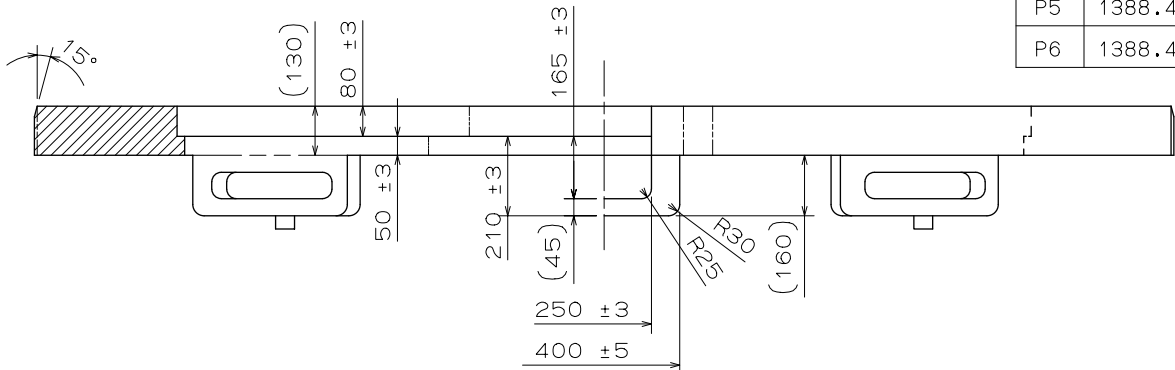

SECTIONAL VIEW of 6H(12H) DIRECTION

SIDE VIEW of 3H DIRECTION

Scale : 5/1
Unit : 1=1/100mm

Version:1

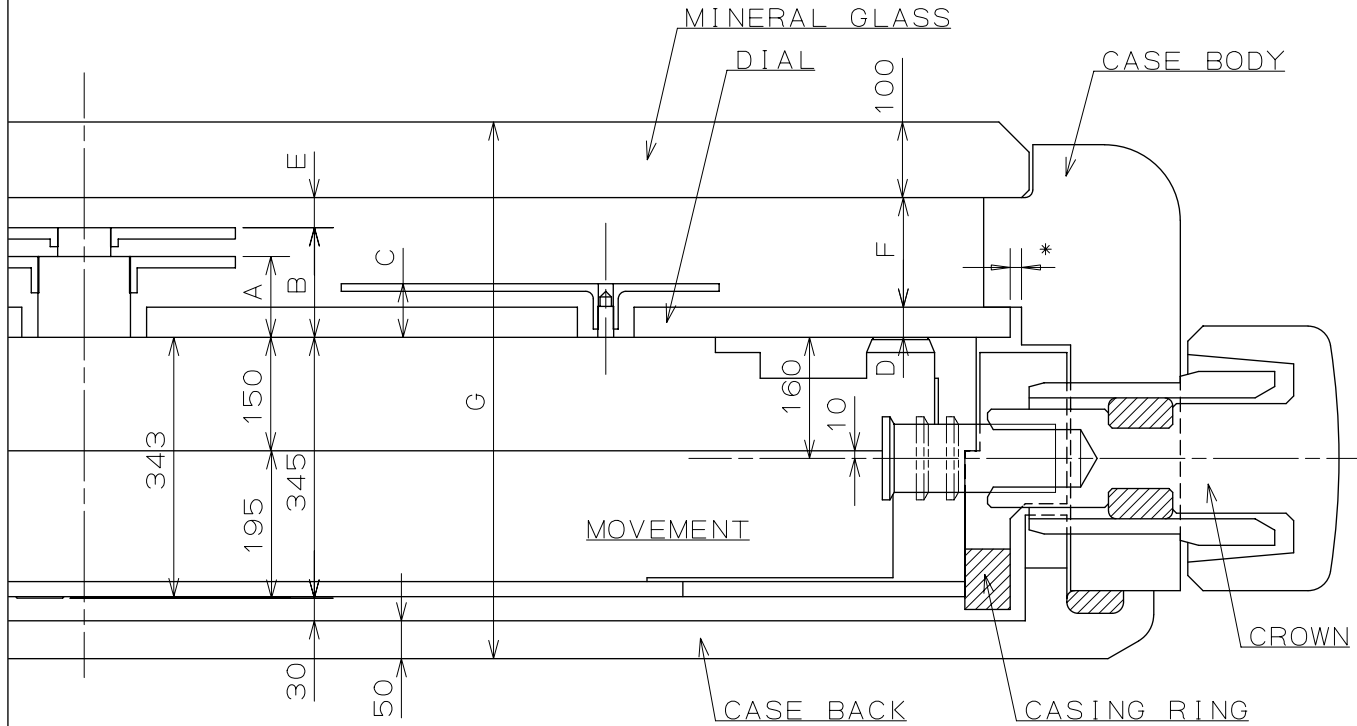

	A	B	C	D	E	F	G
TYPE M	112	150	71	40	35	145	710
TYPE L	180	230	126	85	40	185	795

*Recommended Dimension(Clearance of DIAL and CASE BODY):15

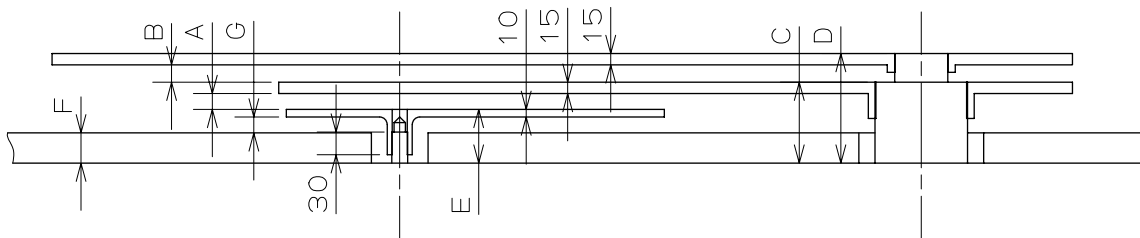

	A	B	C	D	E	F	G
TYPE M	26	23	112	150	71	40	21
TYPE L	39	35	180	230	126	85	31

Scale : 10/1

Unit : 1=1/100mm

Version:6

TYPE M

MINUTE

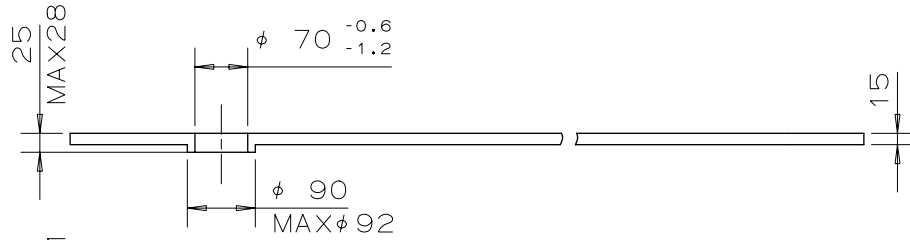

HOUR

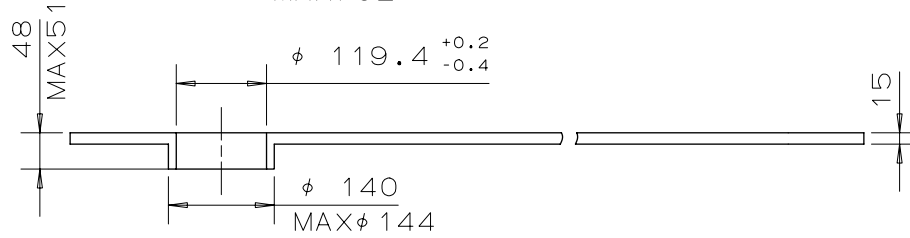

SMALL SECOND
DAY
DATE

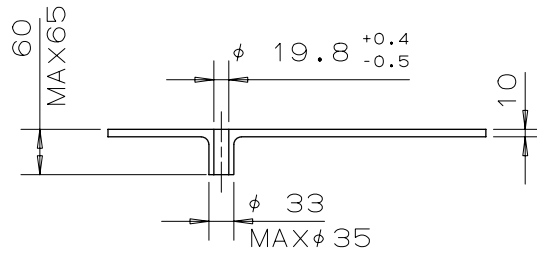

TYPE L

MINUTE

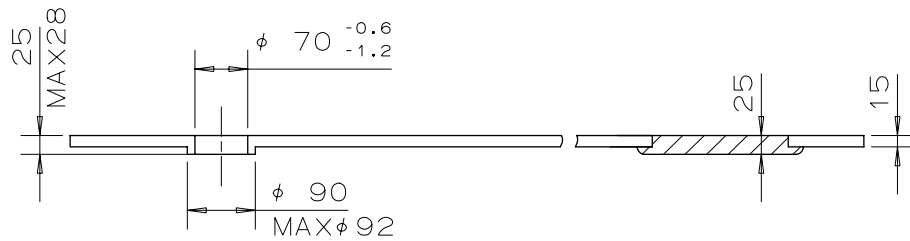

HOUR

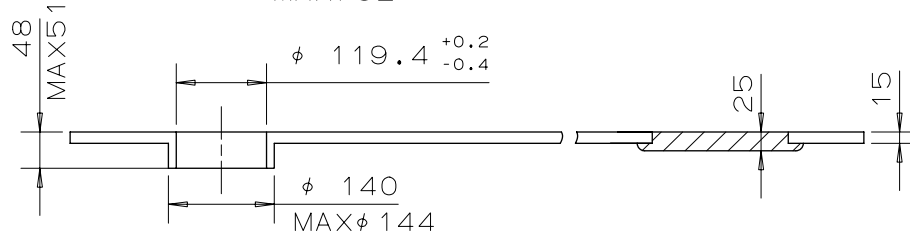

SMALL SECOND
DAY
DATE

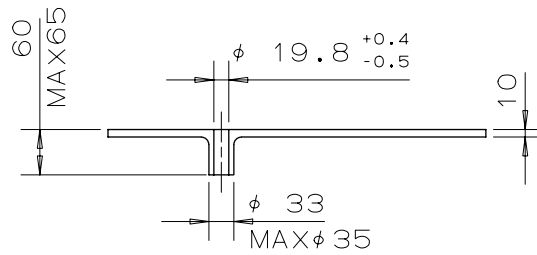

Scale : 10/1

Unit : 1=1/100mm

Version:2