

Cal. VJ45B

ϕ 26.40 mm

H 2.94 mm

Item	Version No.
Specification	Version 5
Appearance - 1	Version 2
Appearance - 2	Version 3
Casing	Version 4
Hand Fitting	Version 2
Hand Setting Stem	Version 4
Dial - 1	Version 4
Casing Ring	Version 3
Assembly Plan	Version 3
Hands	Version 3



MOVEMENT SPECIFICATIONS

CAL.VJ45B 11 1/2 Ligne Quartz Movement Three Hands with Day & Wide Date

1. MOVEMENT DIMENSIONS

- Outside diameter 23.50mm (12H~6H) x 23.50mm (3H~9H), ϕ 26.40mm
- Casing diameter 21.90mm (12H~6H) x 23.50mm (3H~9H), ϕ 25.60mm
- Total height 2.94 mm (including the battery)

2. TIME STANDARD

- Type of quartz oscillator Tuning fork
- Frequency of quartz oscillator 32,768 H Z
- Accuracy Monthly rate: Less than 20 seconds per month at normal temperature range
- Regulation device Nil
- Regulation hands unbalance
 - Second : Less than 0.07 μ N·m (7mg·mm)
 - Minute : Less than 0.30 μ N·m (30mg·mm)
 - Hour : Less than 0.30 μ N·m (30mg·mm)

3. BATTERY

- Type Silver oxide battery
- Size ϕ 6.8 x t 2.1 (mm)
- Battery life Approx. 3 years
- Recommended battery SR621SW (SEIZAIKEN)

4. STEPPING MOTOR

- Type Two pole stepping motor
- Step 180° every second

5. JEWEL

0 jewel

6. ANTIMAGNETISM

(direct current magnetic field)

\geq 1600 A / m

7. SHOCK RESISTANCE

On equal level with general quartz movement

8. OPERATING TEMPERATURE RANGE

From - 5°C to + 50°C

9. SETTING MECHANISM

- Crown at normal position Free
- Crown pulled out to 1st click
 - Clockwise : Instant day change
 - Counterclockwise : Instant date change
- Crown pulled out to 2nd click Time setting, second setting and reset switch

10. TEST OF ACCURACY

- Equipment to be used
 - Quartz Tester QT - 99
 - Greiner Quartz Timer - C
 - Witschi Q-Tester 4000
- Duration of measurement 10 seconds
- Microphone to be used Electromagnetic detection type (DM-1)

11. ATTACHED PARTS

Parts Name	Parts Code
Silver oxide battery	3016 - 17G0
Hand setting stem	0351 - 0010

*** All specifications are subject to change without notice.**

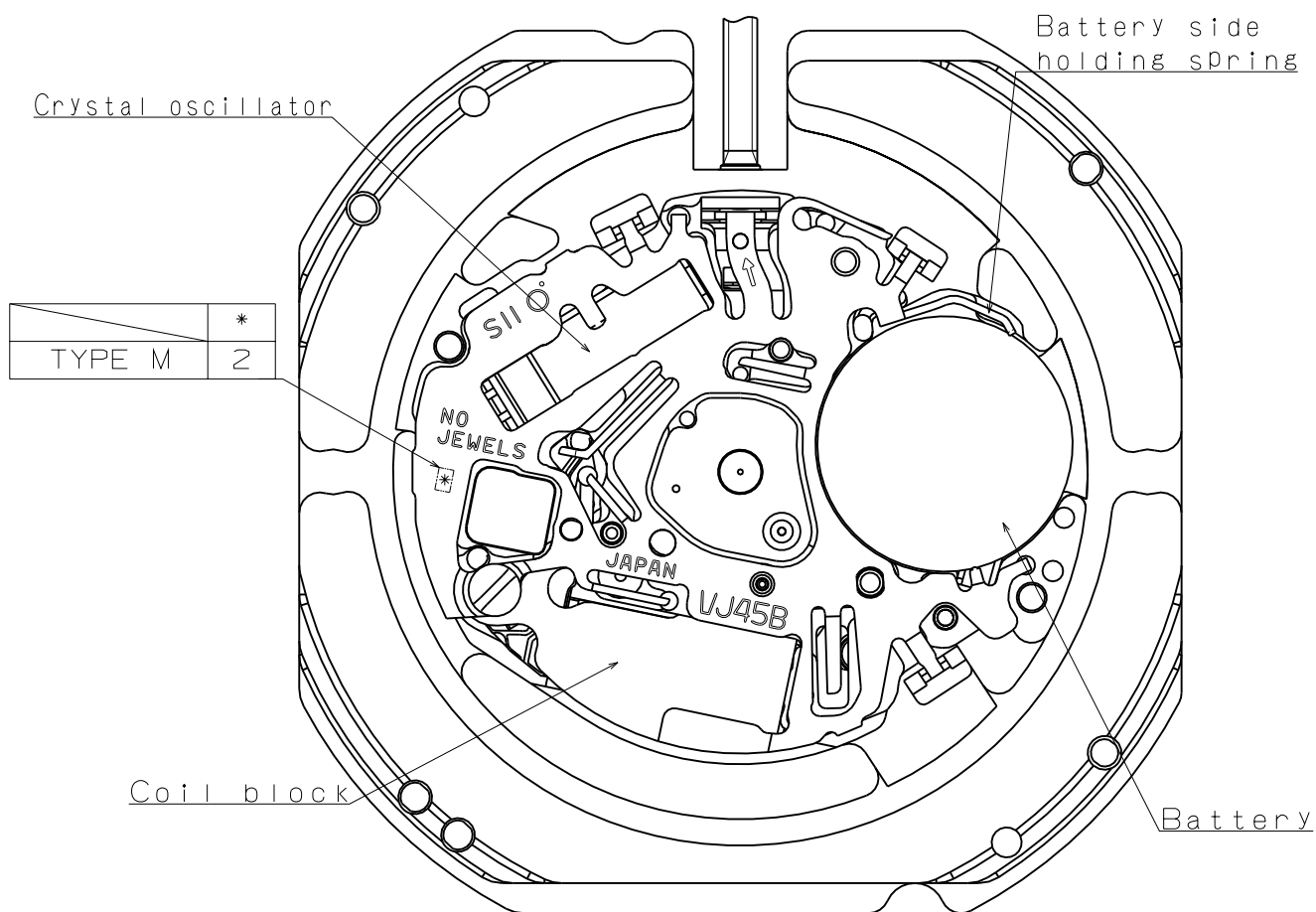

Scale : 5/1

Version:2

Unit : 1=1/100mm

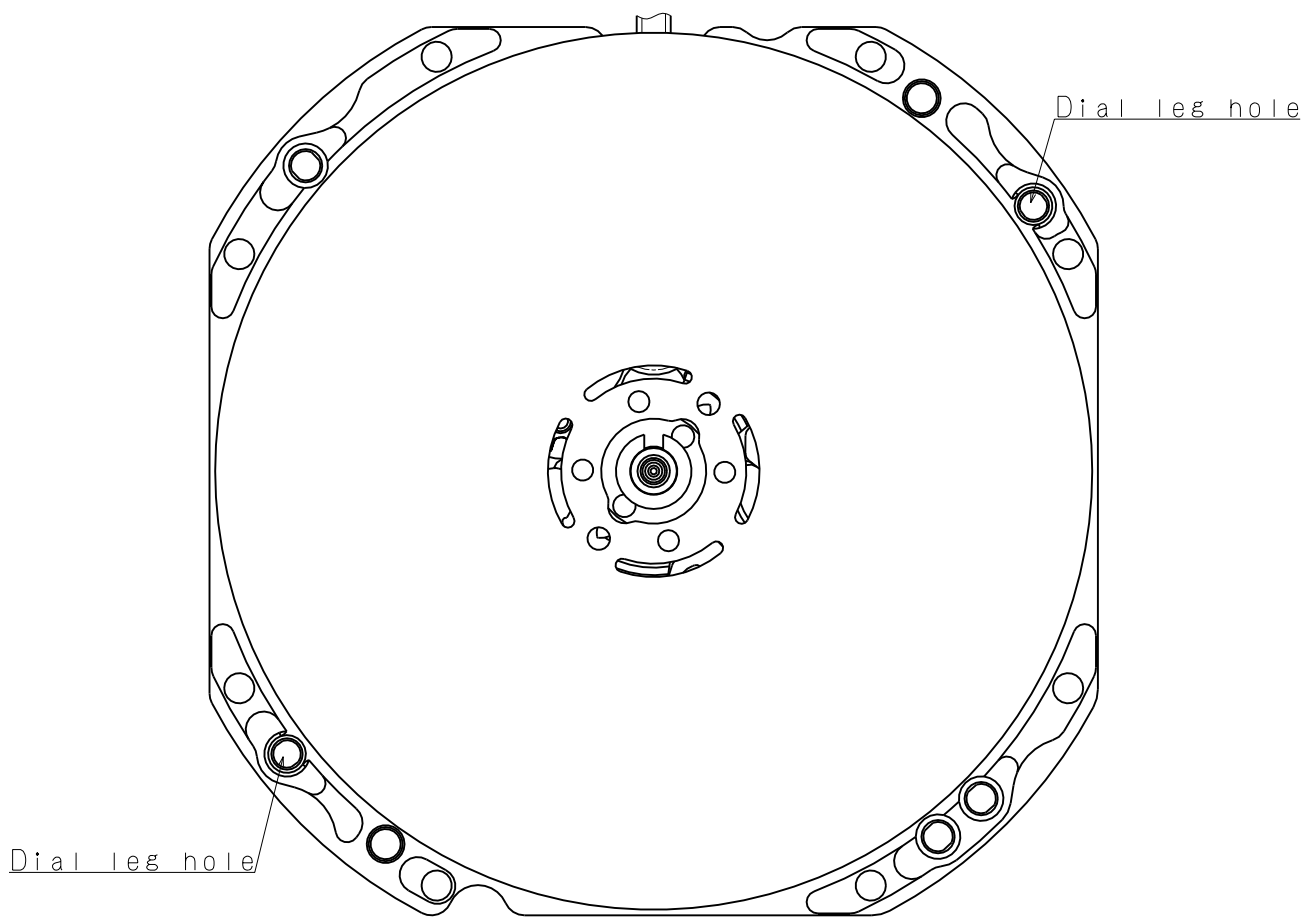

Scale : 5/1

Unit : 1=1/100mm

Version:3

Battery Side holding spring Type.

* First Pull out Stroke 37.5

** Second Pull out Stroke 50

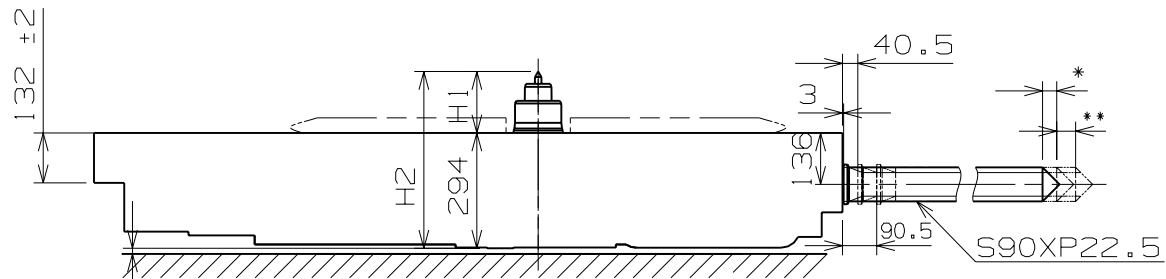

Center post		TYPE M
Maximum height from main plate surface	H1	162.7
Total height incl. movement	H2	456.7

Hand Setting Stem	TYPE A
L1	2413

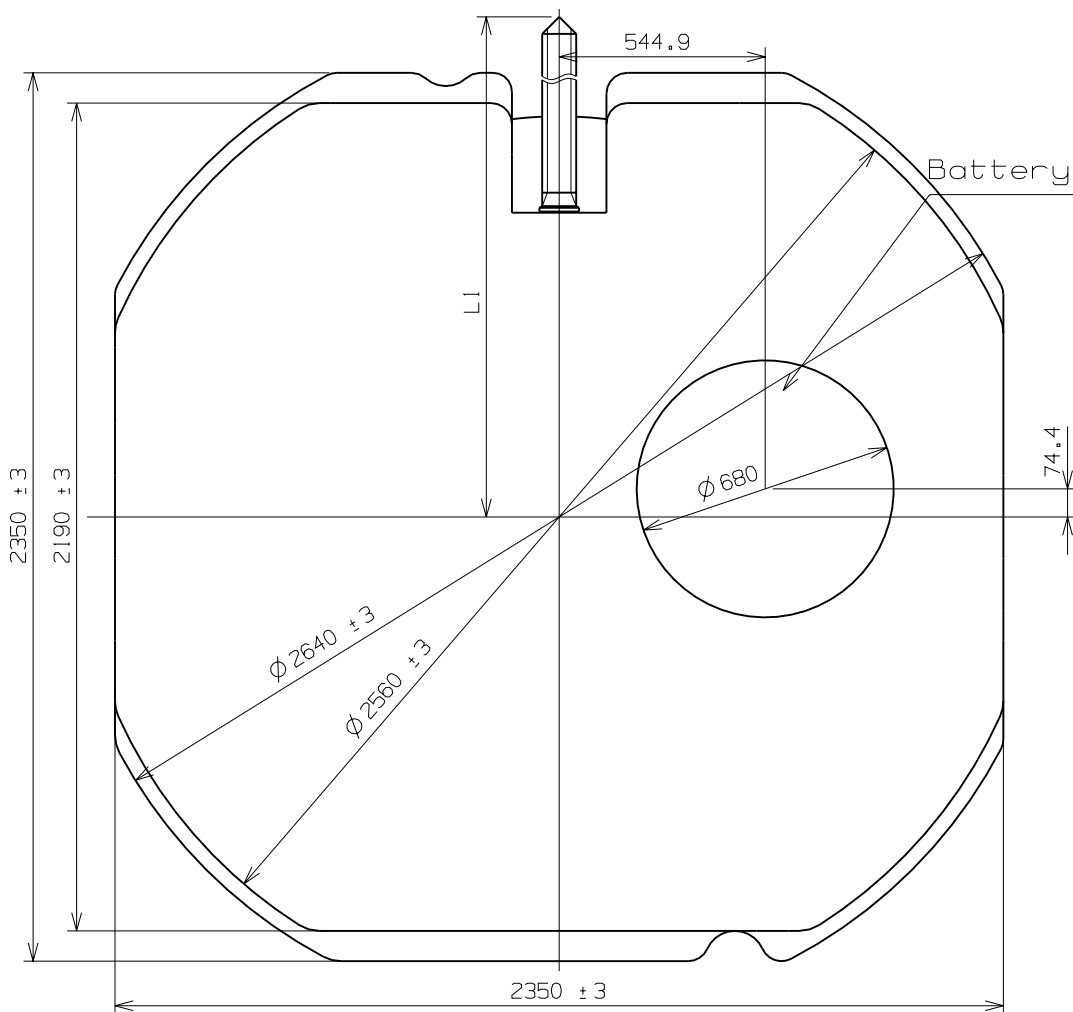

Scale : 5/1

Unit : 1=1/100mm

Version:4

Battery Side holding spring Type.

* First Pull out Stroke 37.5

** Second Pull out Stroke 50

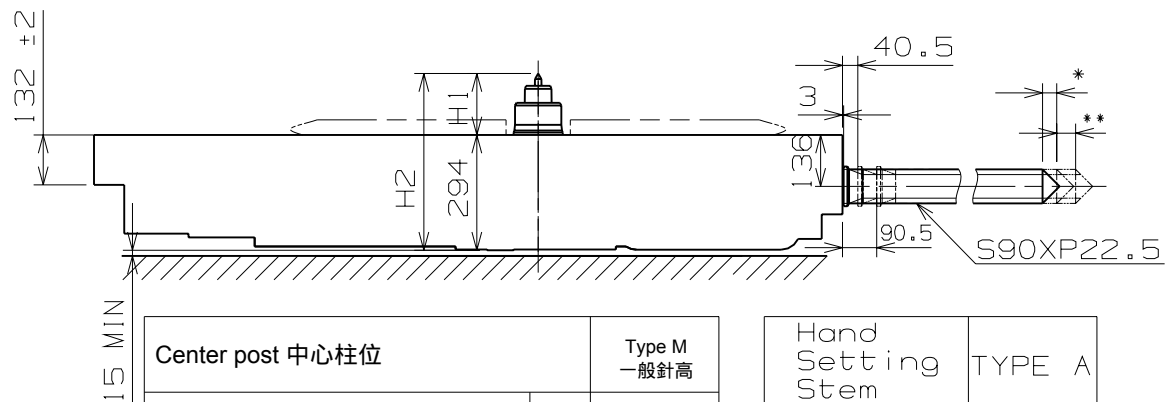

Center post 中心柱位		Type M 一般針高
Maximum height from main plate surface 與機芯平面之最大高度	H1	162.7
Total height incl. movement 機芯總高度	H2	456.7

Hand Setting Stem	TYPE A
L1	2413

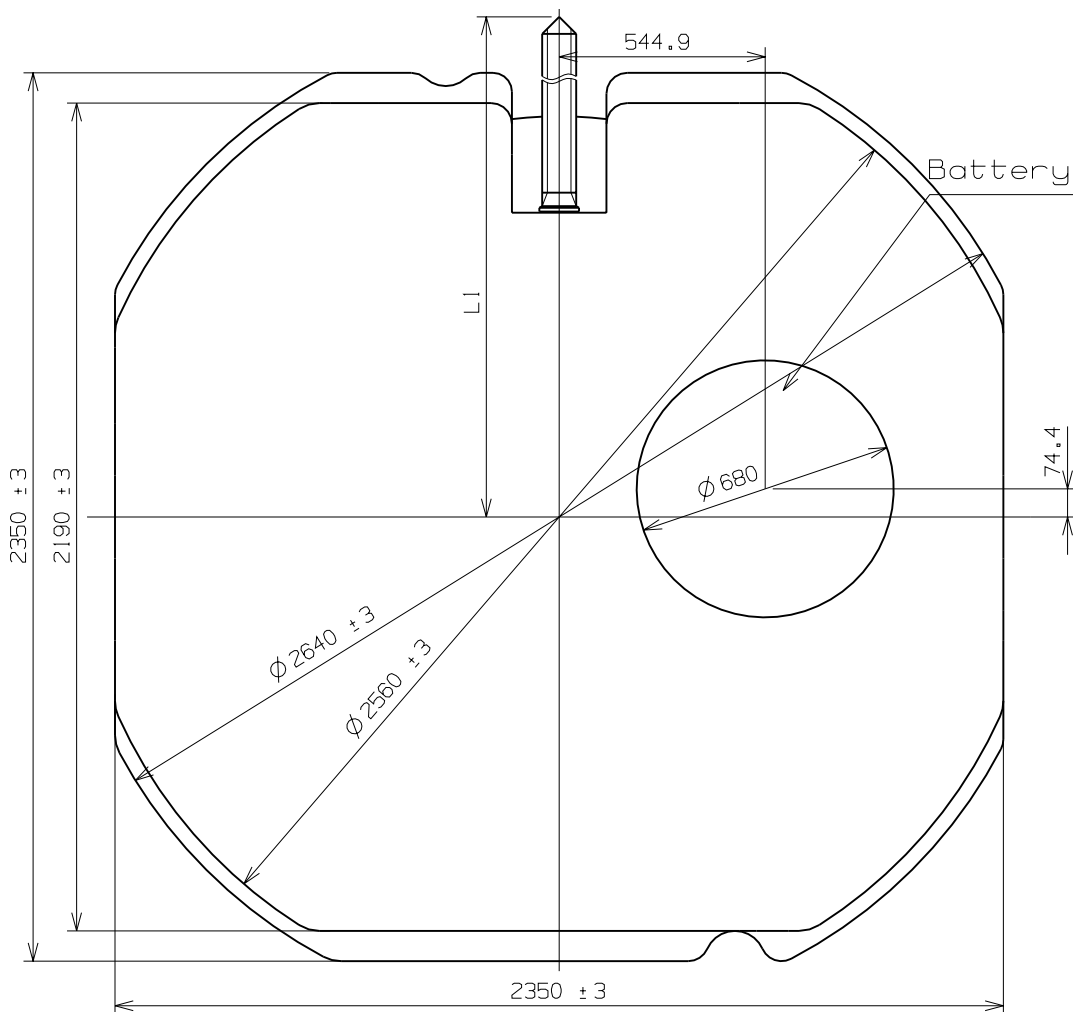

Scale : 5/1

Unit : 1=1/100mm

Version:4

Hour hand unbalance $\leq 0.3\mu\text{N}\cdot\text{m}$ (30mg·mm)
 Minute hand unbalance $\leq 0.3\mu\text{N}\cdot\text{m}$ (30mg·mm)
 Second hand unbalance $\leq 0.07\mu\text{N}\cdot\text{m}$ (7mg·mm)

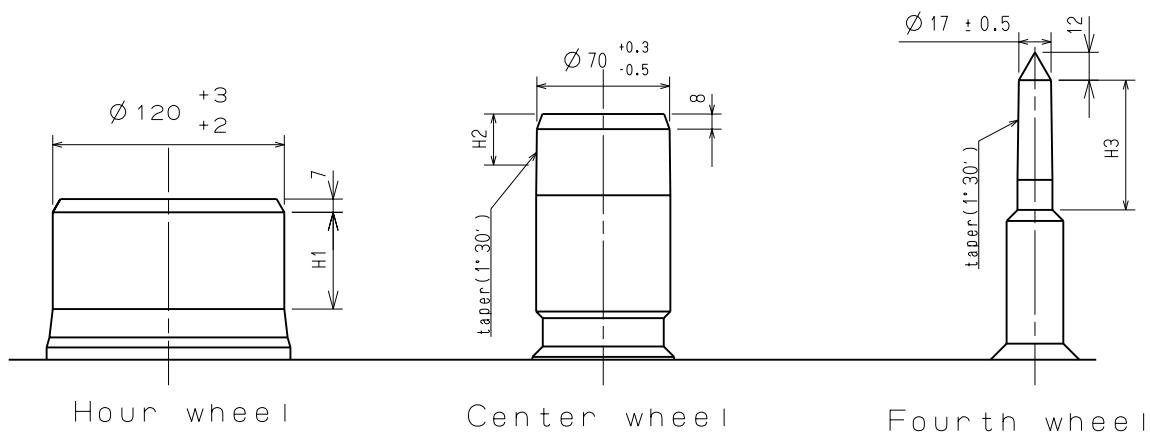

	Part. No.			Dimension		
	Hour wheel	Center wheel	Fourth wheel	H1	H2	H3
TYPE M	0273 0170	0221 0660	0144 1250	51	27	69

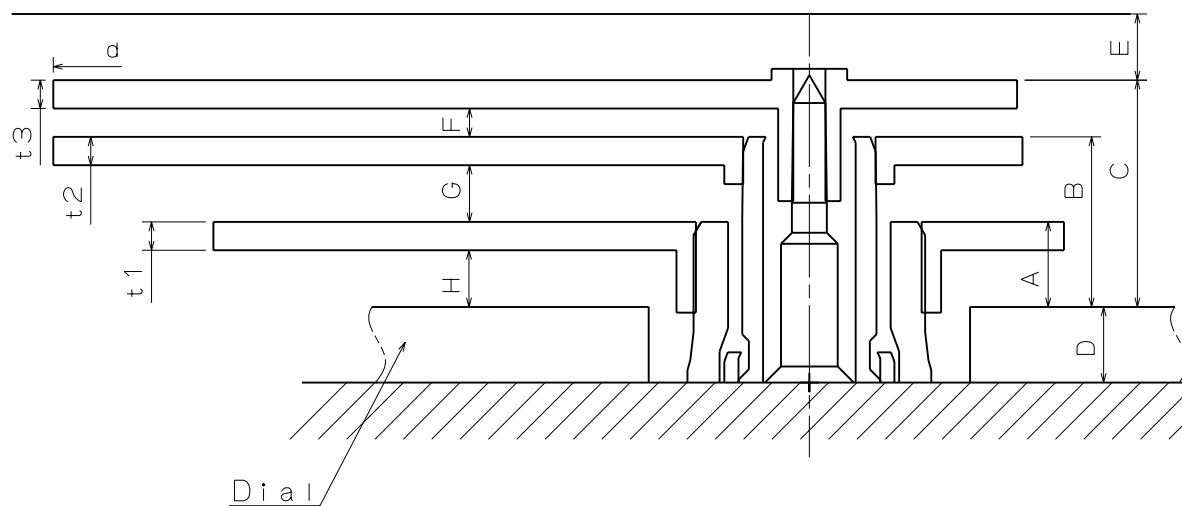

	A	B	C	D	E	F	G	H	t1	t2	t3	d
TYPE M	45	90	120	40	35	15	30	30	15	15	15	$\phi 2500\text{MAX}$

Scale : 25/1

Unit : 1=1/100mm

Version:2

Hour hand unbalance $\leq 0.3\mu\text{N}\cdot\text{m}$ (30mg·mm)
 Minute hand unbalance $\leq 0.3\mu\text{N}\cdot\text{m}$ (30mg·mm)
 Second hand unbalance $\leq 0.07\mu\text{N}\cdot\text{m}$ (7mg·mm)

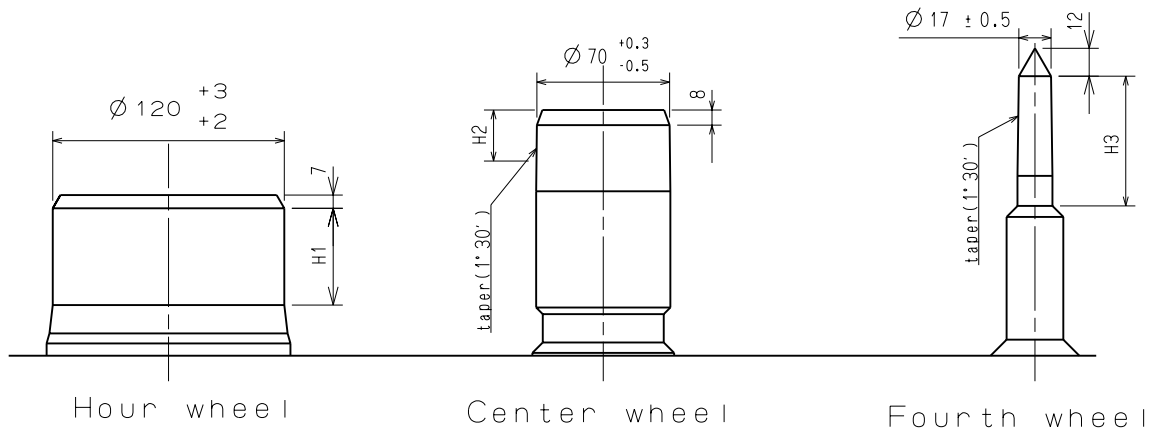

	Part. No.			Dimension		
	Hour wheel 時針輪	Center wheel 分針輪	Fourth wheel 秒針輪	H1	H2	H3
Type M 一般針高	0273 0170	0221 0660	0144 1250	51	27	69

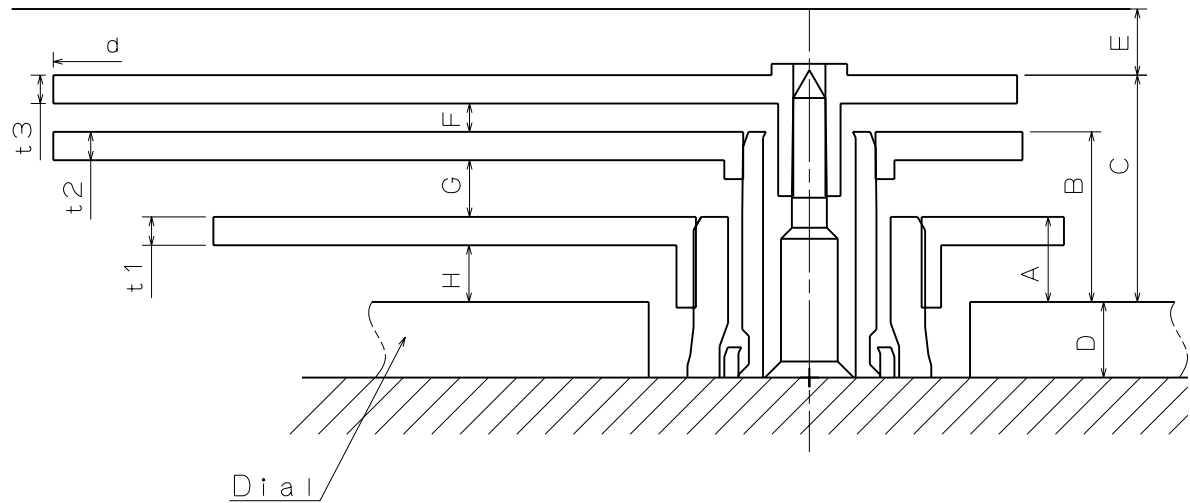

	A	B	C	D	E	F	G	H	t1	t2	t3	d
Type M 一般針高	45	90	120	40	35	15	30	30	15	15	15	∅ 2500MAX

Scale : 25/1

Unit : 1=1/100mm

Version:2

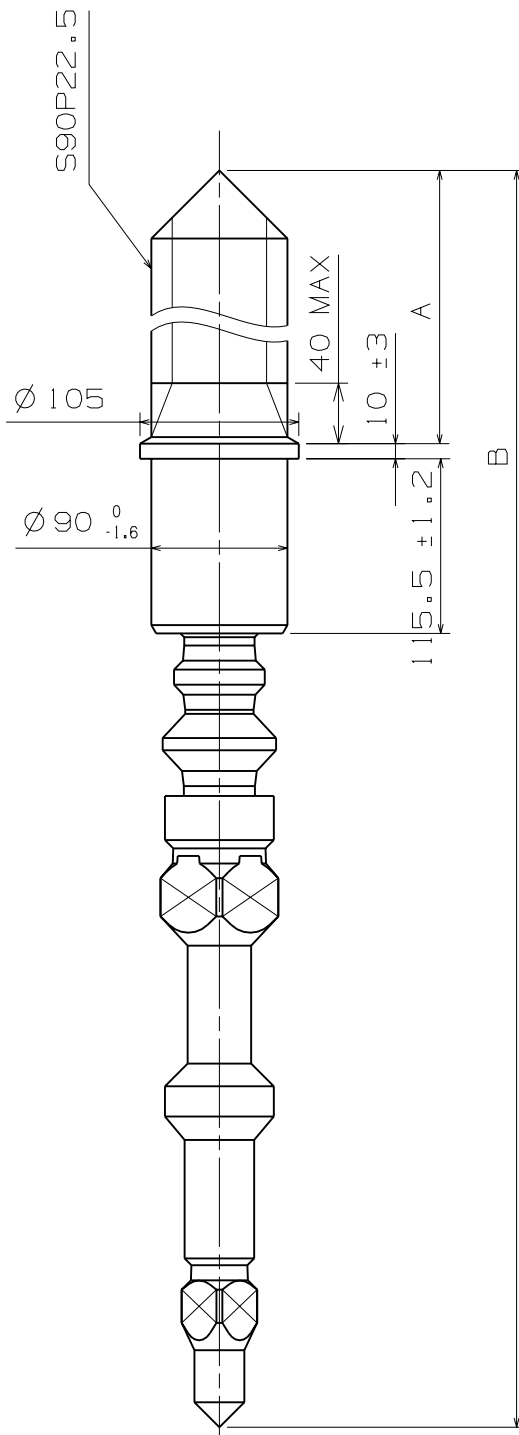

Part.No.	A	B
0351 0010	1595	2245.5

Scale : 20/1

Unit : 1=1/100mm

Version:4

Casing Ring

Cal. VJ45B

	X	Y
P1	±1375.00	±400.00
P2	±300.00	±1375.00
P3	-1375.00	300.00

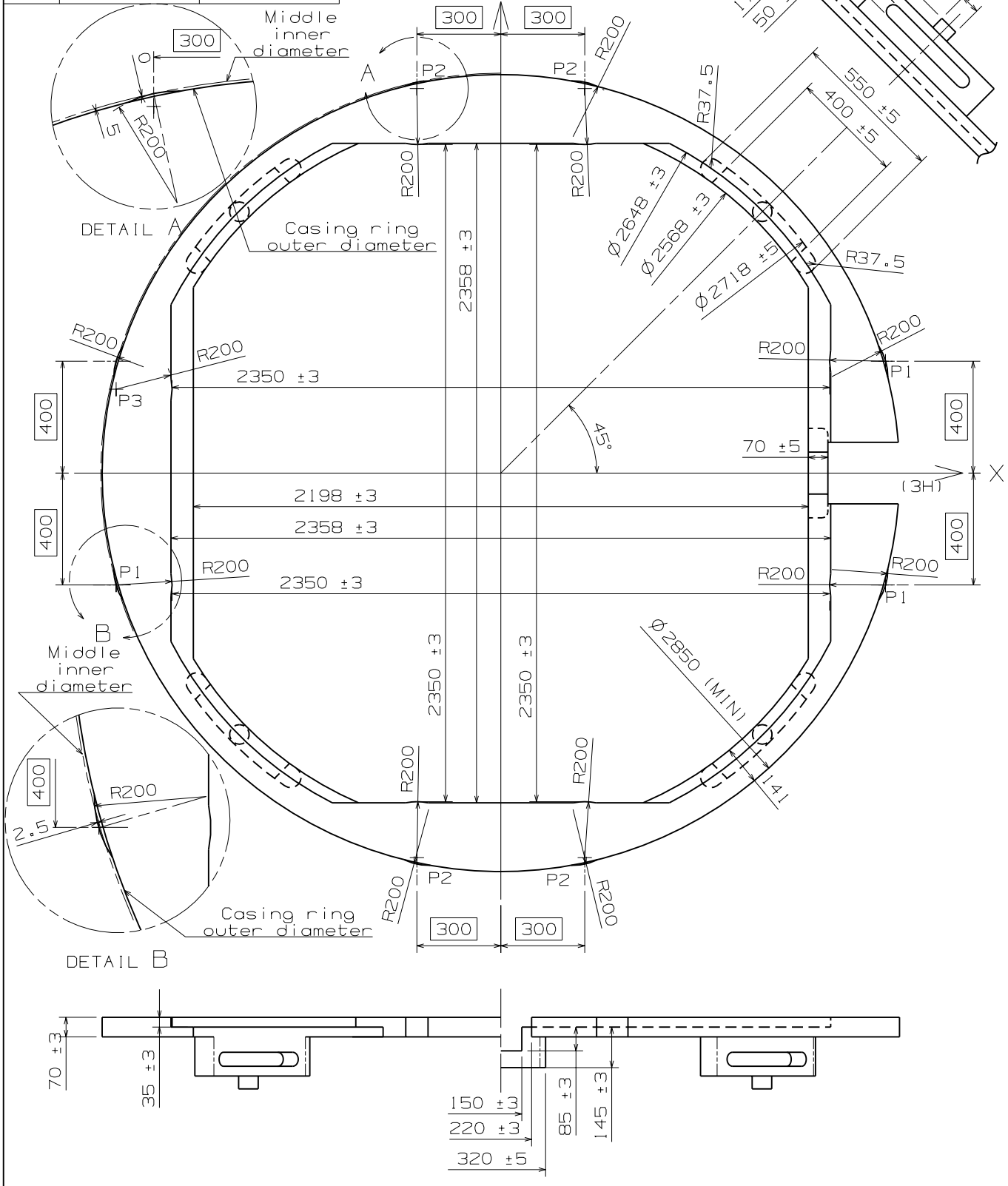

Scale : 5/1

Unit : 1=1/100mm

Version:3

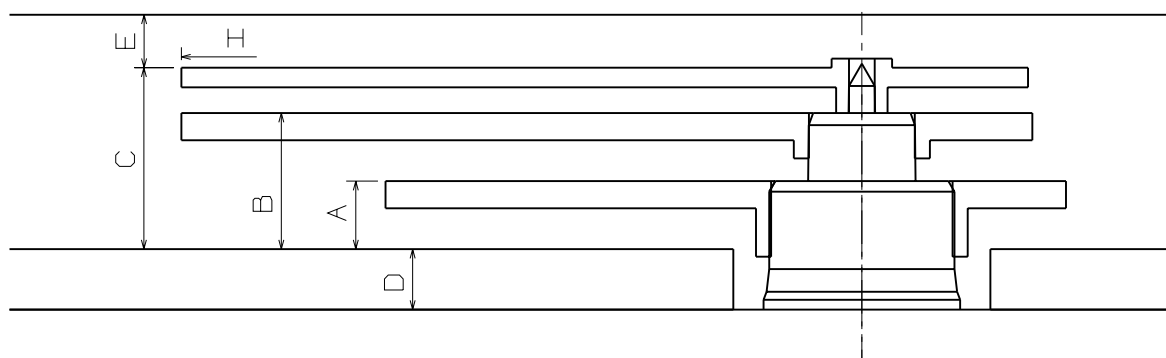
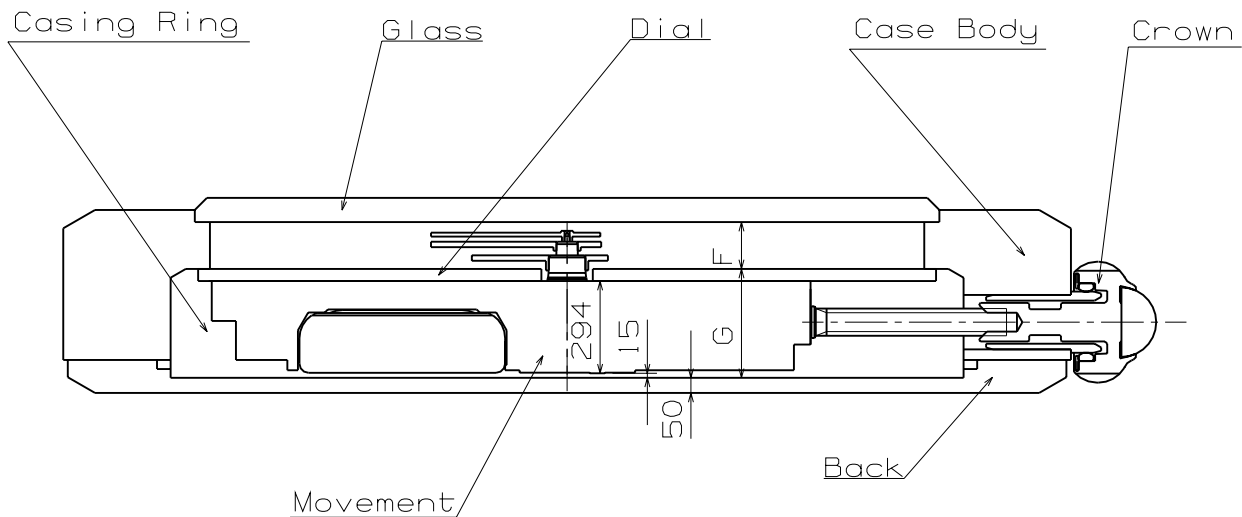

	A	B	C	D	E	F	G	H
TYPE M	45	90	120	40	35	155	349	∅ 2500MAX

Scale : -
Unit : 1=1/100mm

Version:3

SECOND

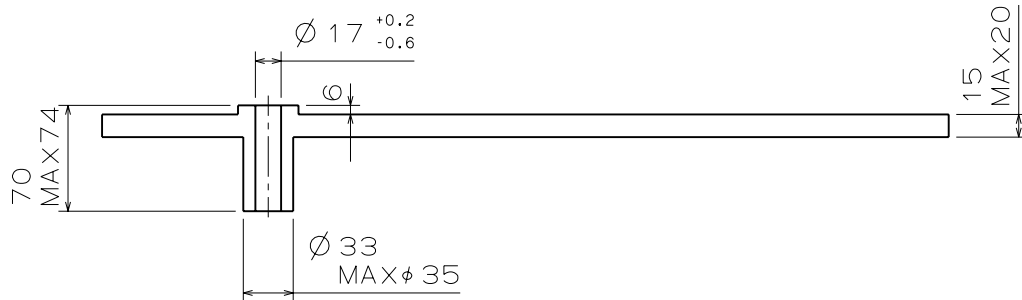

MINUTE

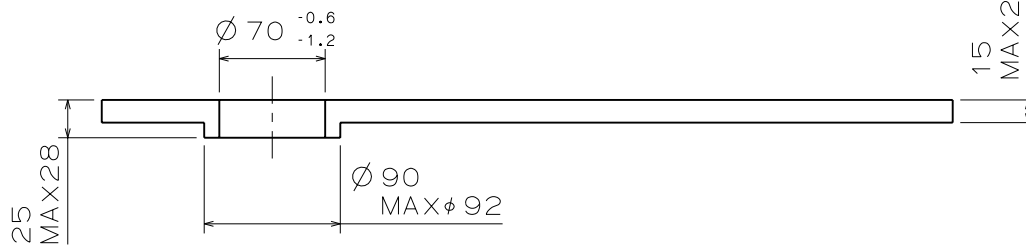

HOUR

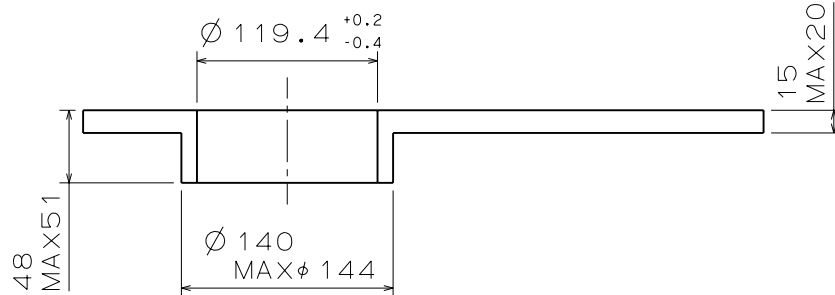

Scale : 20/1
Unit : 1=1/100mm

Version : 3