

# Cal. VD55C

$\phi$  29.50 mm

H 3.97 mm

Item	Version No.
Specification - 1	Version 2
Specification - 2	Version 1
Appearance	Version 1
Casing	Version 1
Hand Fitting	Version 2
Hand Setting Stem	Version 1
Dial - 1	Version 1
Assembly Plan - 1	Version 1
Assembly Plan - 2	Version 1
Hands	Version 1



## MOVEMENT SPECIFICATION - 1

### CAL.VD55C 12 3 / 4 Ligne Quartz Movement Three Hands with 3 Eyes ( Minute, Second, 1 / 10 Second Chronograph )

#### 1. MOVEMENT DIMENSIONS

- Outside diameter  $\phi$  29.50mm (12H-6H) x 26.00mm (3H-9H)
- Casing diameter  $\phi$  28.80mm (12H-6H)
- Total height 3.97 mm
- Dimensions of small hands away from center 7.50 mm

#### 2. TIME STANDARD

- Type of quartz oscillator Tuning fork
- Frequency of quartz oscillator 32,768 H Z
- Accuracy Monthly rate: Less than 20 seconds per month at normal temperature range
- Regulation device Nil
- Regulation hands unbalance
  - Second : Less than 0.09  $\mu$ N·m ( 9mg·mm )
  - Minute : Less than 0.90  $\mu$ N·m ( 90mg·mm )
  - Hour : Less than 0.60  $\mu$ N·m ( 60mg·mm )
  - Chronograph hands : Less than 0.05  $\mu$ N·m ( 5mg·mm )
  - 1/10 chronograph hand : Less than 0.40  $\mu$ g·m<sup>2</sup> ( 400mg·mm<sup>2</sup> ) (Disc hand)
- The moment of inertia
- Additional function Stopwatch : up to 1 minute in 1/10 second ( 2 seconds per round )  
up to 60 minutes in 1 second split time

#### 3. BATTERY

- Type Silver oxide battery
- Nominal voltage 1.55 V
- Size  $\phi$  9.5 x t 2.0 ( mm )
- Battery life Approx. 3 years
- Recommended battery SR920SW ( SEIZAIKEN )

#### 4. DIAL FIXED METHOD

The dial is fixed by two dial leg holes of the main plate

#### 5. JEWEL

0 jewel

#### 6. ANTIMAGNETISM

( direct current magnetic field )

$\geq$  1600 A / m

#### 7. SHOCK RESISTANCE

On equal level with general quartz movement

#### 8. OPERATING TEMPERATURE RANGE

From - 5 °C to + 50 °C

#### 9. TEST OF ACCURACY

- Equipment to be used SEIKO Quartz Tester QT - 99  
Greiner Quartz Timer - C  
Witschi Q-Tester 4000
- Duration of measurement 10 seconds
- Microphone to be used Electromagnetic detection type

**\* All specifications are subject to change without notice.**

**Movement Specification - 2**

**CAL. VD55C**

**OPERATION**

3 step motors ( 3 hands, 1 / 10 sec. chrono. maximum to 60 minutes )

Chronograph 1/10 second hand  
(This chronograph hand moves for the first minute which indicates the measurement time in 1/10 unit)

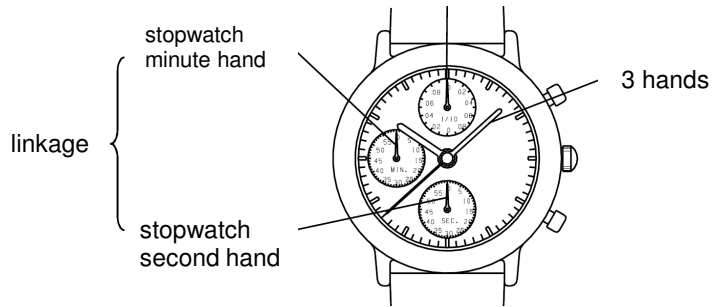

Normal position 1st click  
adjusting minute, hour & chrono.

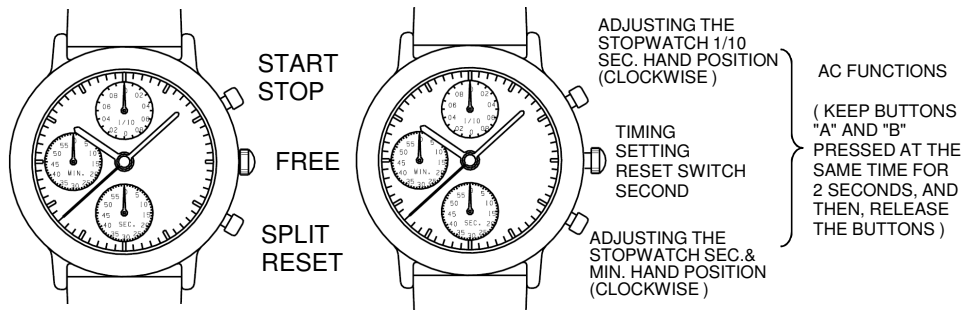

- \* Stopwatch 1/10 second hand moves 2 seconds for 1 circle.
- \* Pull the crown to 2nd click to adjust the stopwatch hand position.
- \* AC functions is available if stopwatch hand position is disorderly.
- \* When using AC functions, stopwatch hand moves back and returned to where it was ( second hand moves 1/2 circle counterclockwise and 1/2 circle clockwise, 1/10 second hand moves 1 circle clockwise )

Version 1

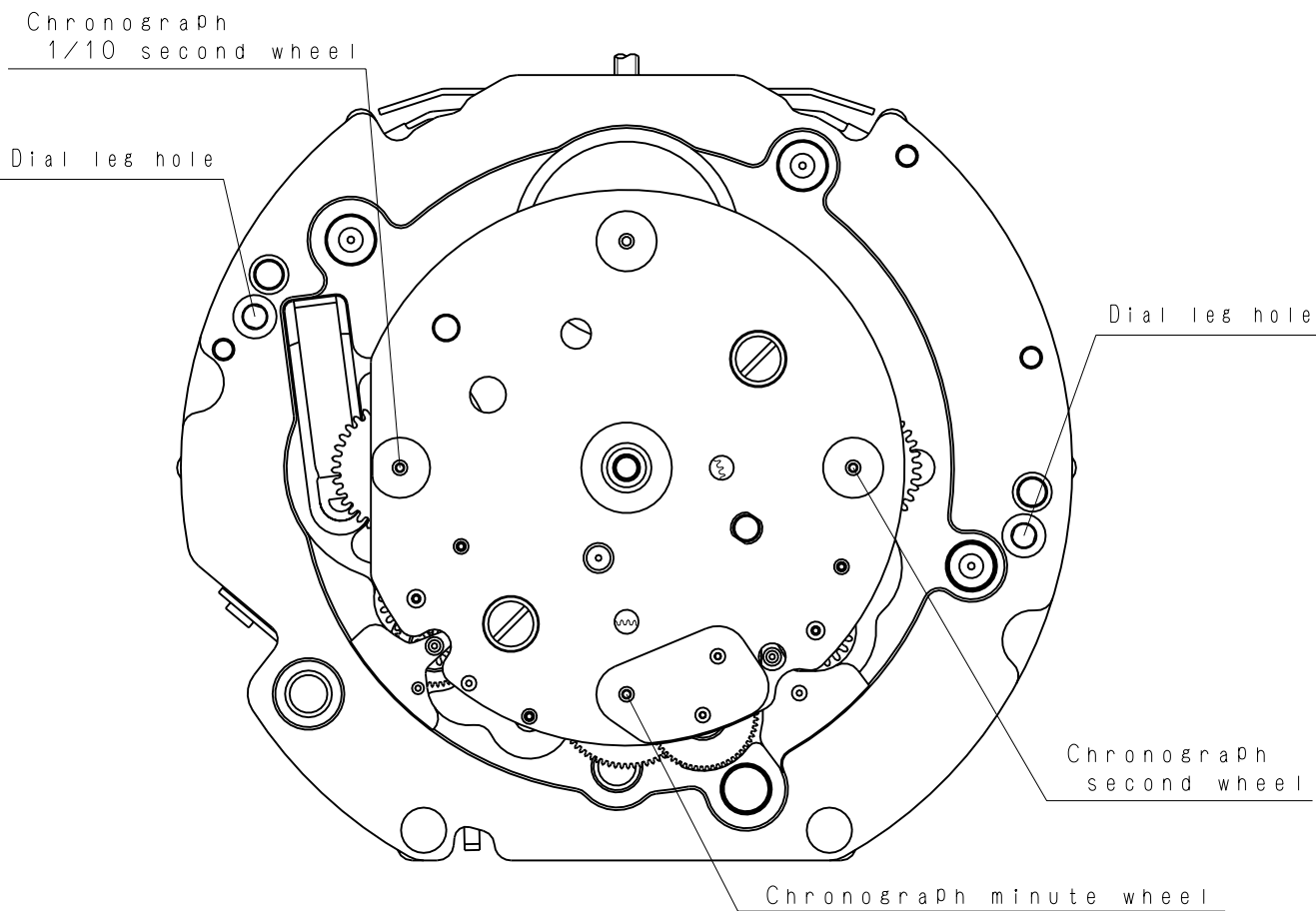
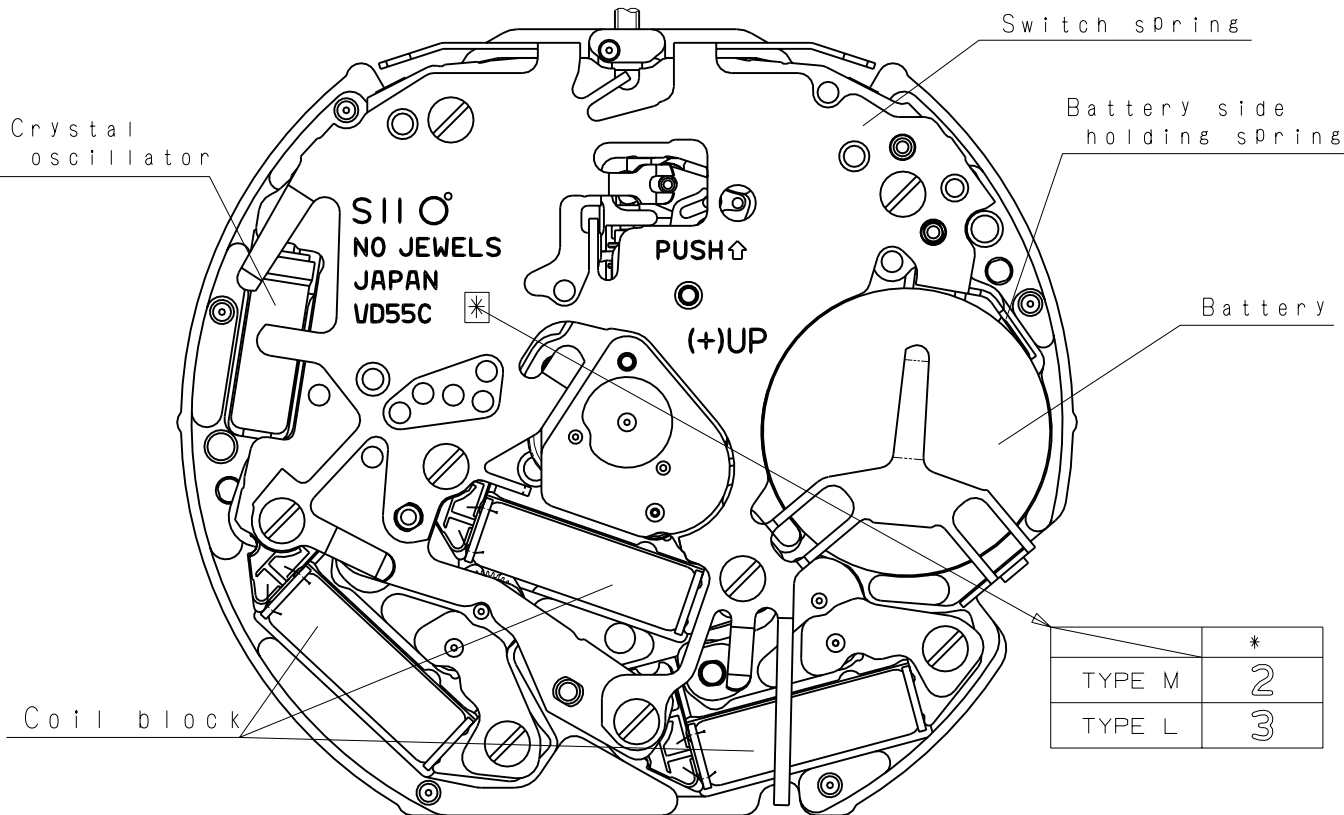

Scale : 4/1  
Unit : 1=1/100mm

Version:1

\*Pull out stroke 42.9

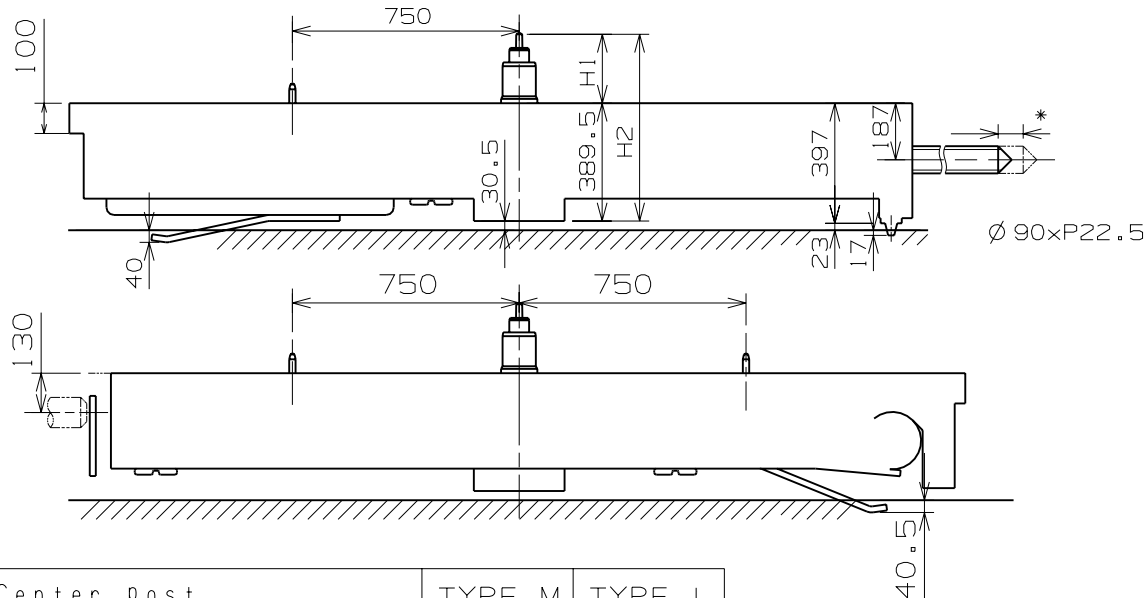

Center Post		TYPE M	TYPE L
Maximum height from main plate surface	H1	228	273
Total height incl. movement	H2	617.5	662.5

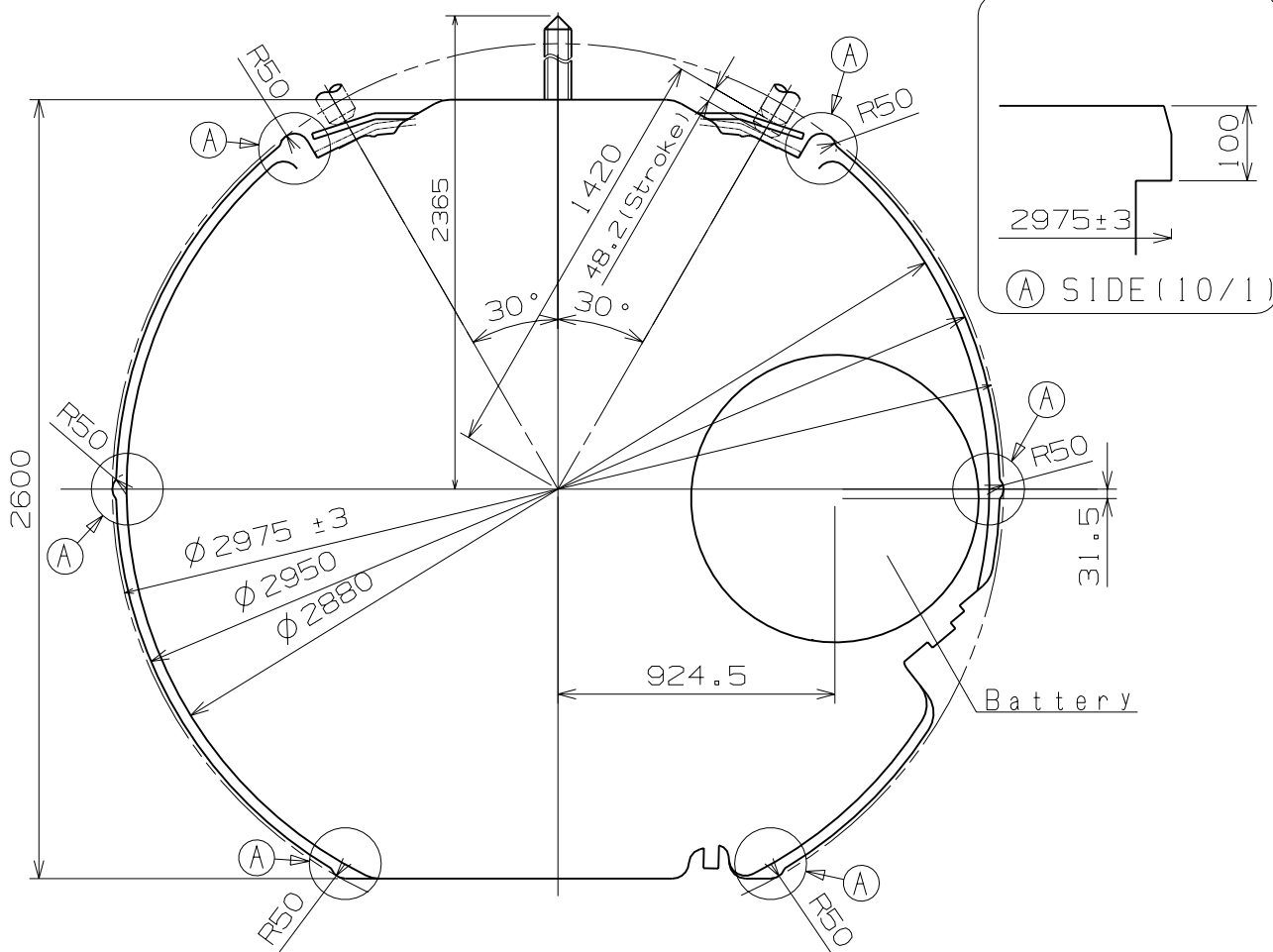

Scale : 4/1  
Unit : 1=1/100mm

Version:1



# Hand fitting

Cal. VD55C

- \*Unbalance
  - Hour hand  $\leq 0.6 \mu\text{N}\cdot\text{m}$  (60mg·mm)
  - Minute hand  $\leq 0.9 \mu\text{N}\cdot\text{m}$  (90mg·mm)
  - Second hand  $\leq 0.09 \mu\text{N}\cdot\text{m}$  (9mg·mm)
  - Chronograph hand  $\leq 0.05 \mu\text{N}\cdot\text{m}$  (5mg·mm)
- \*Movement of inertia
  - 1/10 Chronograph hand  $\leq 0.4 \mu\text{g}\cdot\text{m}^2$  (400mg·mm<sup>2</sup>) (Disc hand available)

	H1	H2
TYPE M	99.5	141
TYPE L	144.5	186

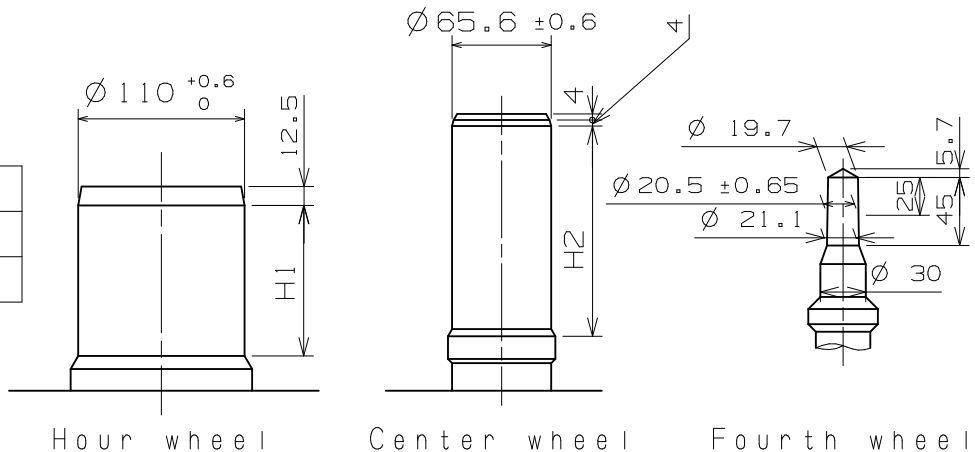

Part name	Part No.	
	TYPE M	TYPE L
Hour wheel	0271 4060	0273 0360
Center wheel	0221 2050	0221 2040
Fourth wheel	0241 1770	0241 4800
Chronograph minute wheel	0902 0070	0902 0030
Chronograph second wheel	0888 0080	0888 0100
Chronograph 1/10 second wheel	0888 0080	0888 0100

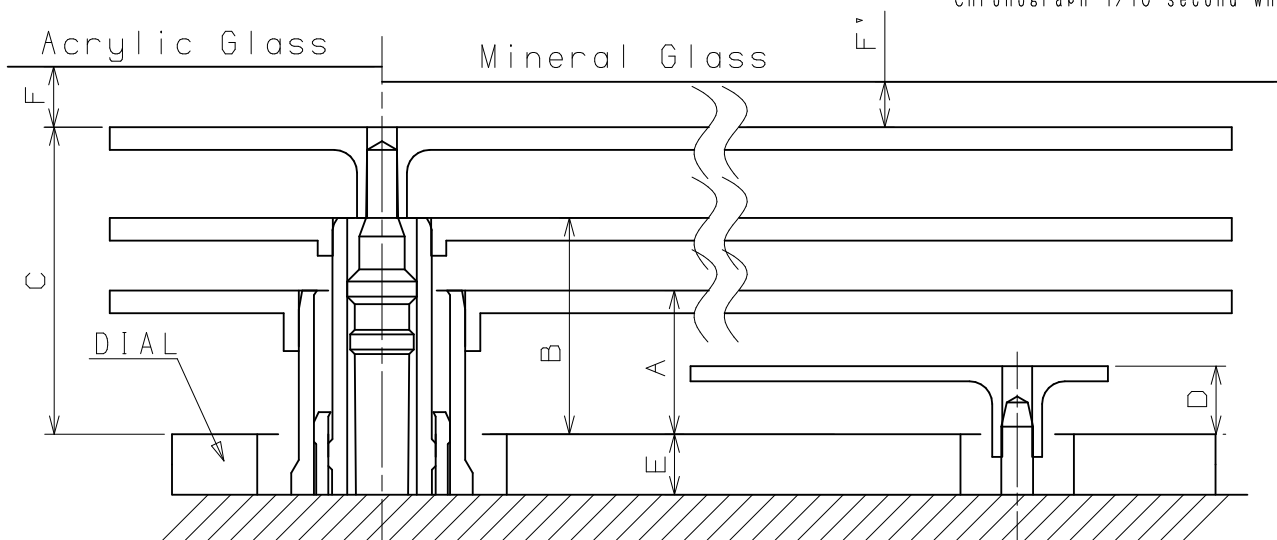
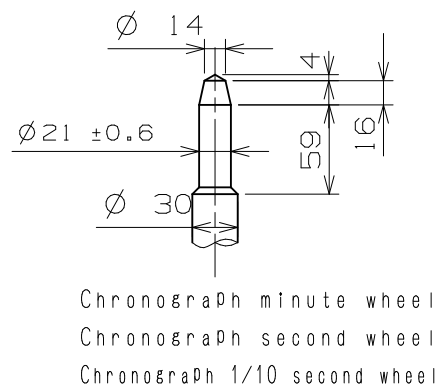

	A	B	C	D	E	F	F'
TYPE M	95	143	203	45	40	50	40
TYPE L	95	143	203	45	85	50	40

Scale : 20/1

Unit : 1=1/100mm

Version : 2

- \*Unbalance
  - Hour hand  $\leq 0.6 \mu\text{N} \cdot \text{m}$  (60mg·mm)
  - Minute hand  $\leq 0.9 \mu\text{N} \cdot \text{m}$  (90mg·mm)
  - Second hand  $\leq 0.09 \mu\text{N} \cdot \text{m}$  (9mg·mm)
  - Chronograph hand  $\leq 0.05 \mu\text{N} \cdot \text{m}$  (5mg·mm)
- \*Movement of inertia
  - 1/10 Chronograph hand  $\leq 0.4 \mu\text{g} \cdot \text{m}^2$  (400mg·mm<sup>2</sup>) (Disc hand available)

	H1	H2
Type M 一般針高	99.5	141
Type L 高針	144.5	186

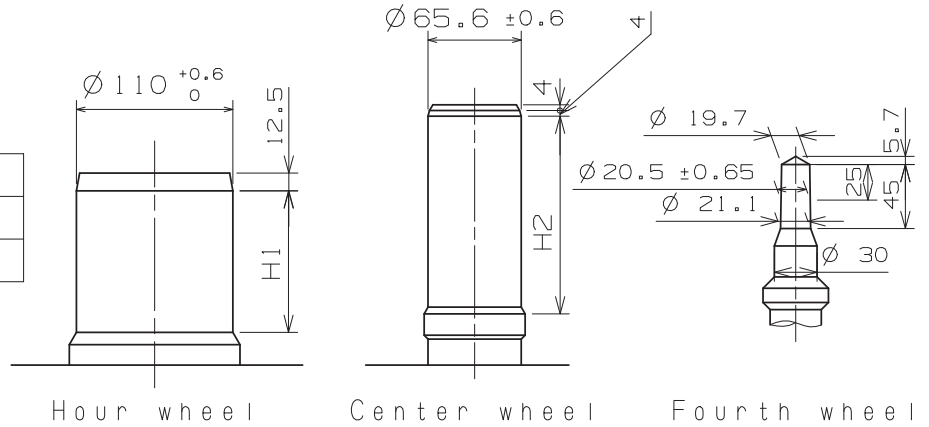

Part name	Part No.	
	Type M 一般針高	Type L 高針
Hour wheel 時針輪	0271 4060	0273 0360
Center wheel 分針輪	0221 2050	0221 2040
Fourth wheel 秒針輪	0241 1770	0241 4800
Chronograph minute wheel 計時分針輪	0902 0070	0902 0030
Chronograph second wheel 計時秒針輪	0888 0080	0888 0100
Chronograph 1/10 second wheel 1/10計時秒針輪	0888 0080	0888 0100

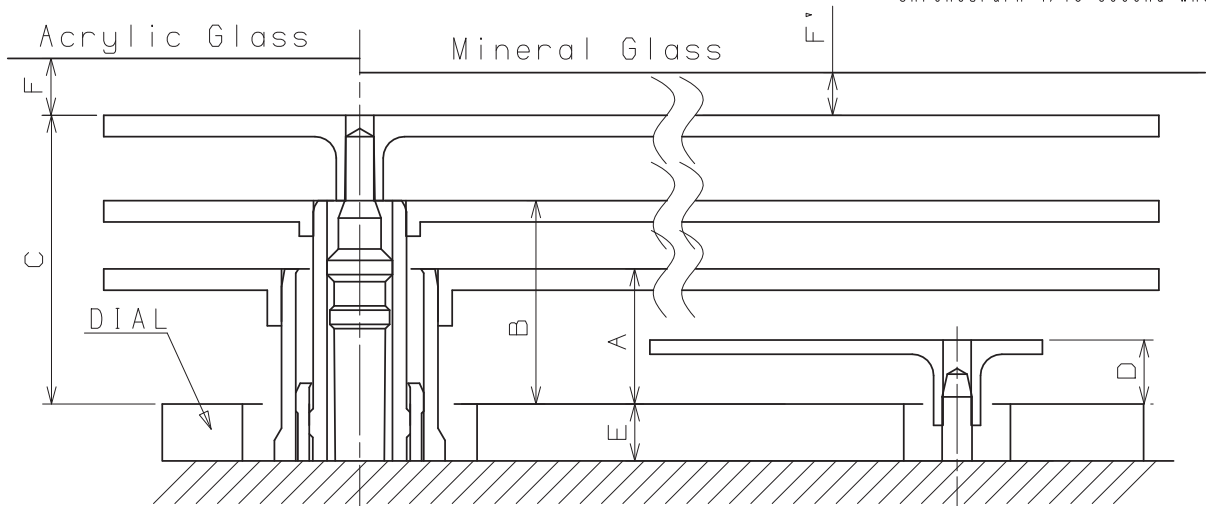
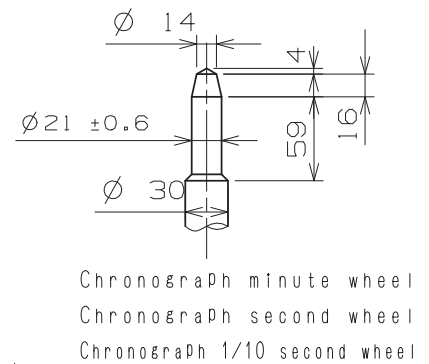

	A	B	C	D	E	F	F'
Type M 一般針高	95	143	203	45	40	50	40
Type L 高針	95	143	203	45	85	50	40

Scale : 20/1

Unit : 1=1/100mm

Version : 2

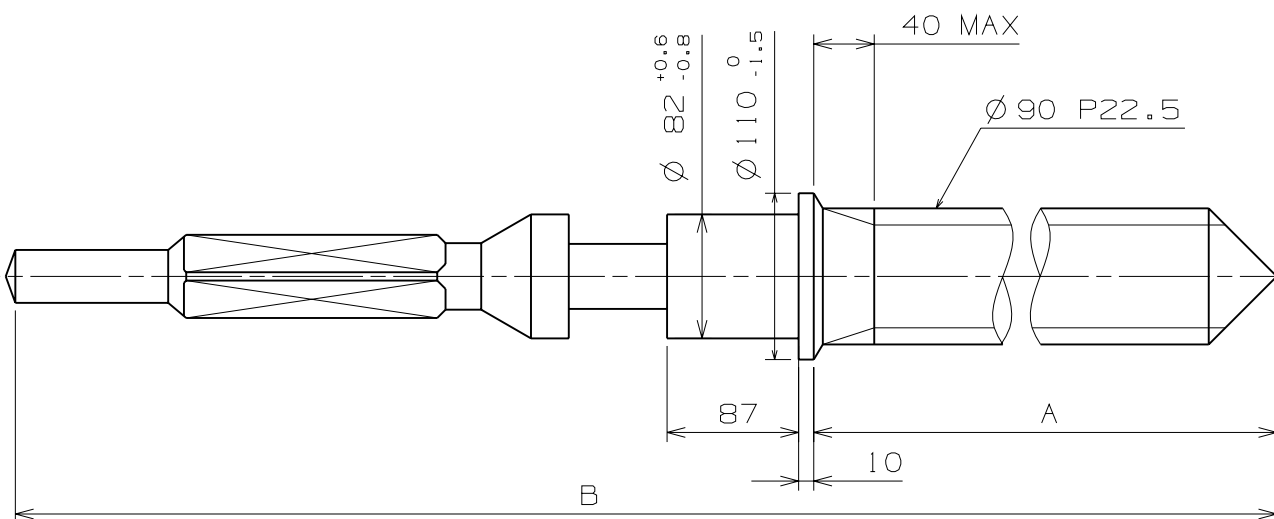

	Part. No.	A	B
TYPE A	0351 1780	1508	2036

Scale : 20/1

Unit : 1=1/100mm

Version:1

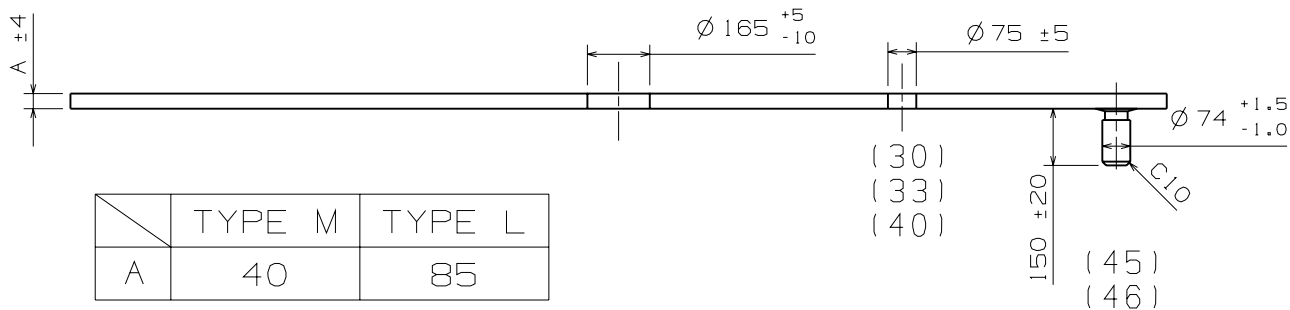
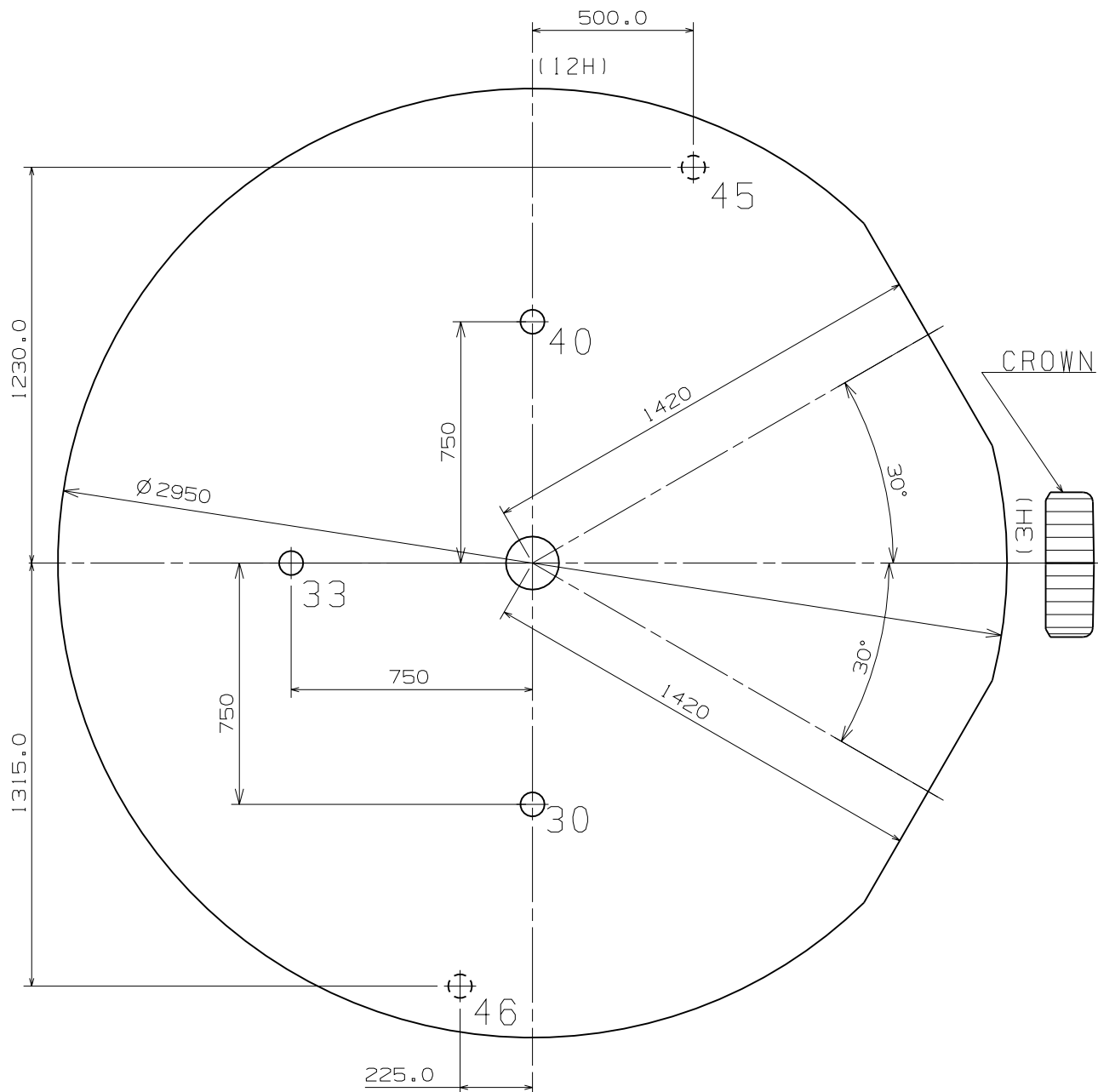

Scale : 5/1  
Unit : 1=1/100mm

Version : 1

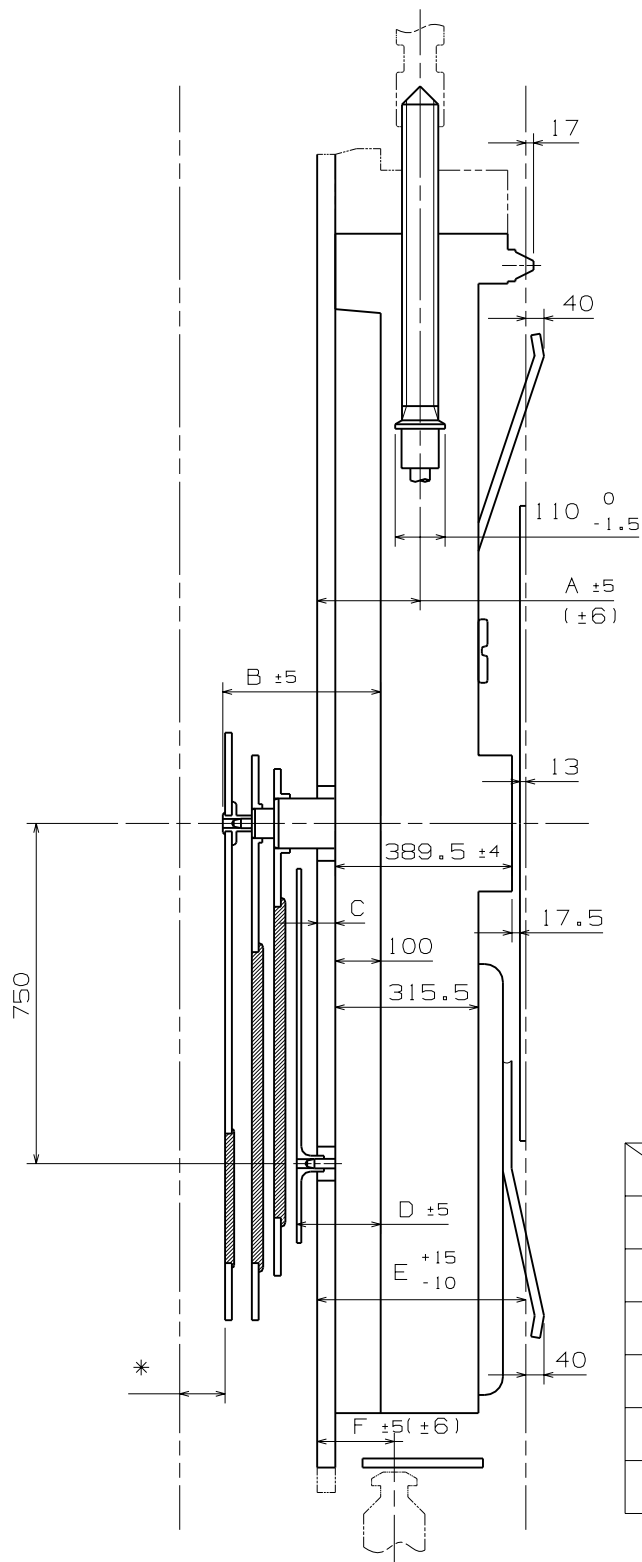

	TYPE M	TYPE L
A	227	272
B	343	388
C	40	85
D	185	230
E	460	505
F	170	215

\*Acrylic Glass 50  
\*Mineral Glass 40

Scale : ≠  
Unit : 1=1/100mm

Version : 1

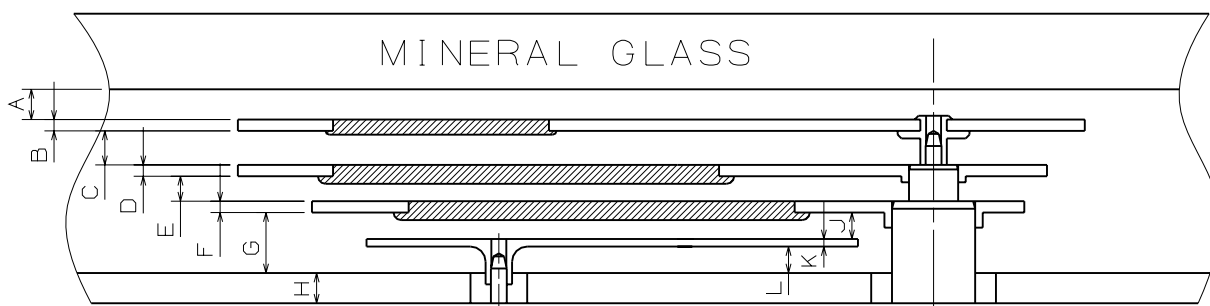
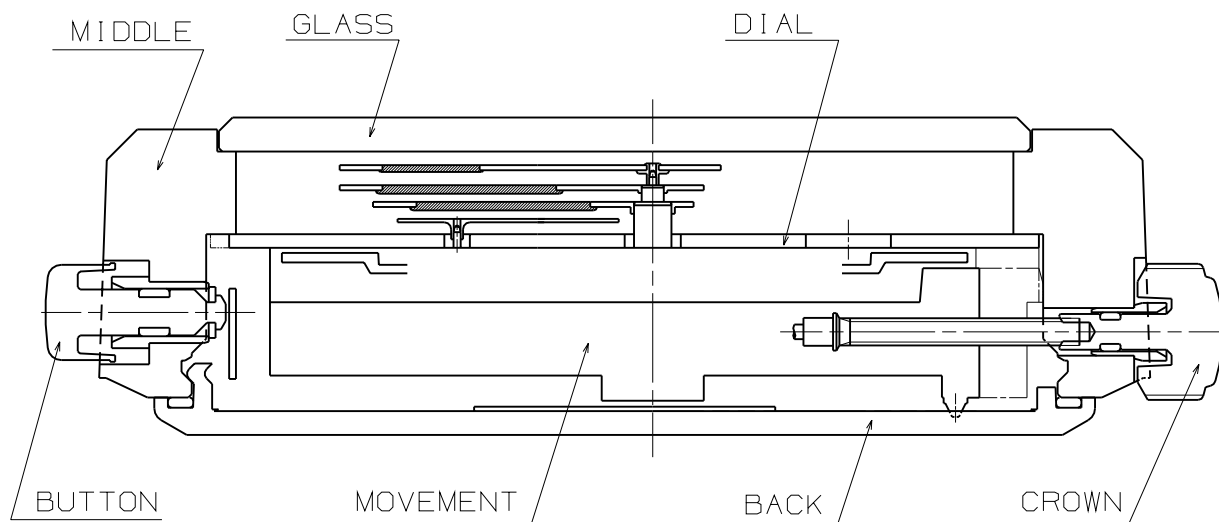

	TYPE M	TYPE L
A	40	40
B	15	15
C	45	45
D	15	15
E	33	33
F	15	15
G	80	80
H	40	85
J	35	35
K	10	10
L	35	35

Scale :  $\neq$   
Unit : 1=1/100mm

Version : 1

## SECOND

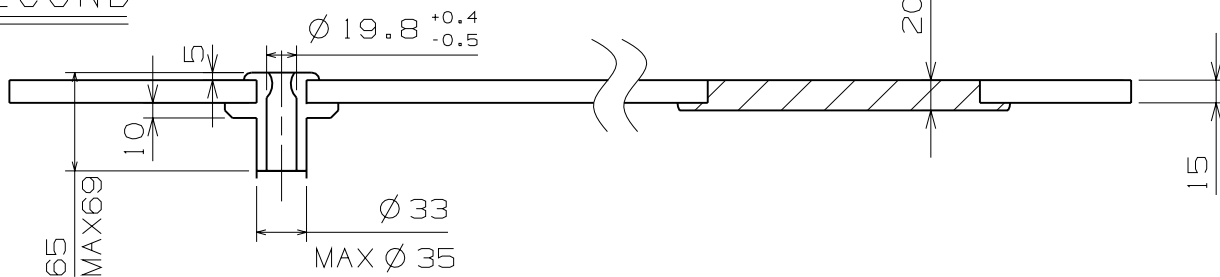

## MINUTE

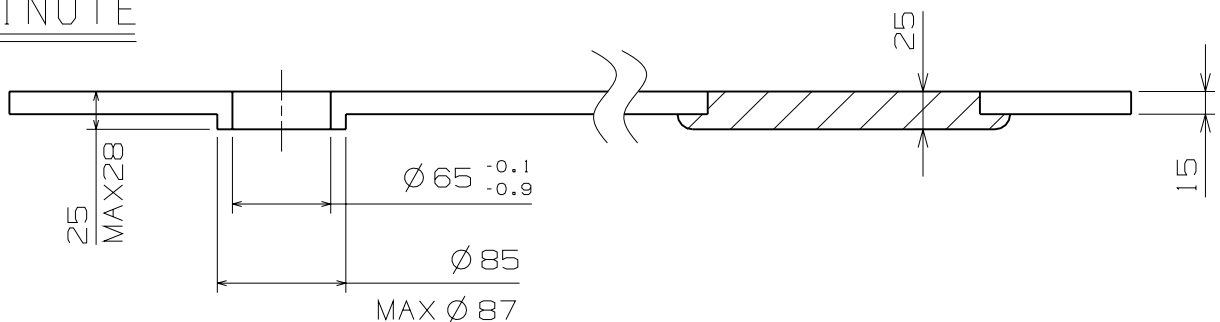

## HOUR

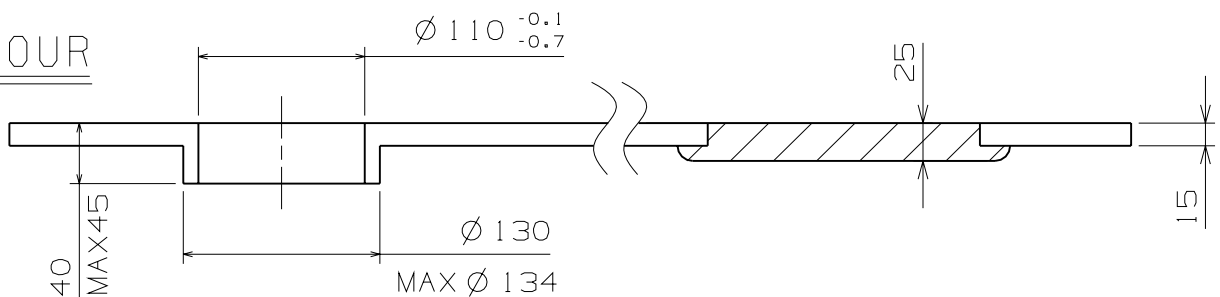

## CHRONO

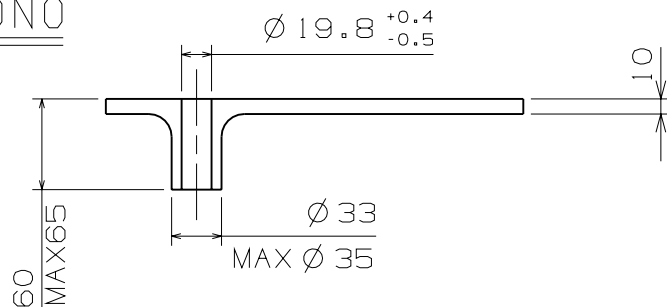

Scale : 20/1  
Unit : 1=1/100mm

Version : 1