

RONDA normtech 700 & 6000

Long battery-life and special functionality

Caliber 6203.B – 11½'''

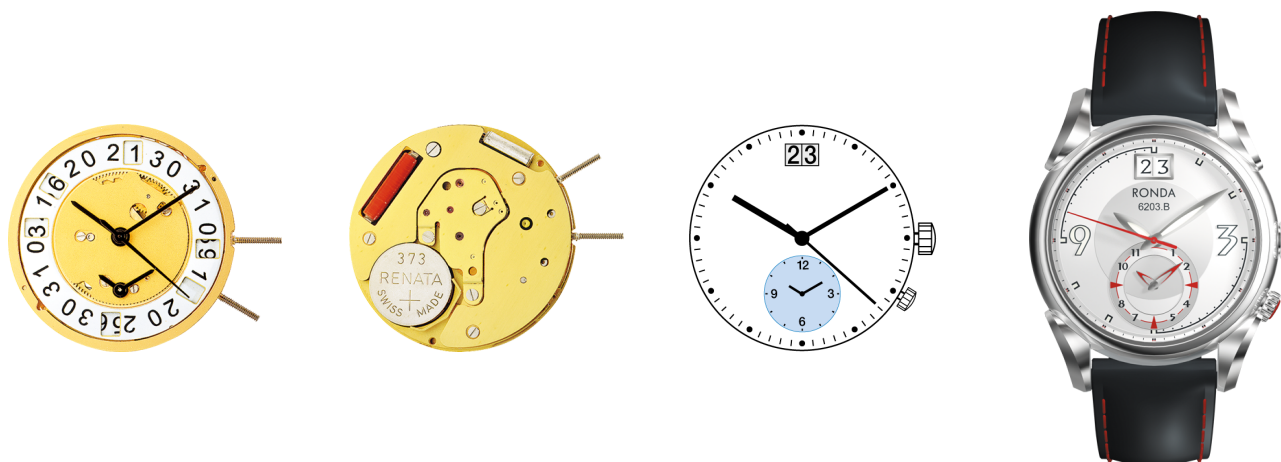

Product Specifications

Analogue quartz movement	
Line	normtech
Caliber	6203.B
Size	11½'''
Version	Swiss Made Swiss Parts
	5 Jewels / gold plated 1 Jewels / nickel plated
Standard battery life	40 months
Hand fitting height	1

Features

- Repairable metal watch movement
- Power saving mechanism with pulled out stem: Reduction of consumption approximately 70%

Functions

- 1 eye
- Multifunction
- Second time zone
- Big date
- 3 hands

Technical Specifications

Diameter Total	26.00 mm
Case fitting	25.60 mm
Movement height	3.30 mm
Height over standard battery	3.30 mm
Movement rest	0.60 mm
Height over stem	1.80 mm
Length of stem travel	0.90 mm
Force to push the stem for screwed crown	10 / 17,5 N
Stem thread	0.90 mm
Standard battery	373
Standard battery life	40 months
Battery voltage	1.5 V
Current consumption – typical	1.03 µA (Date Mechanism not in Gear)
Current consumption – maximum	1.45 µA (Date Mechanism not in Gear)
Useful torque second – typical	6 µNm
Useful torque minute – typical	300 µNm
Operating temperature	0 - 50 °C
Instantaneous rate	-10/ +20 sec/month
Resistance to magnetic fields	18.8 Oe
Resistance against shock	NIHS 91-10



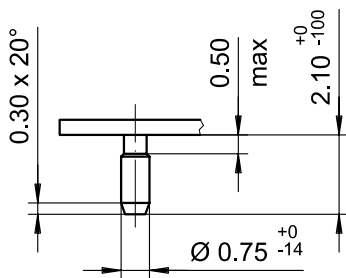
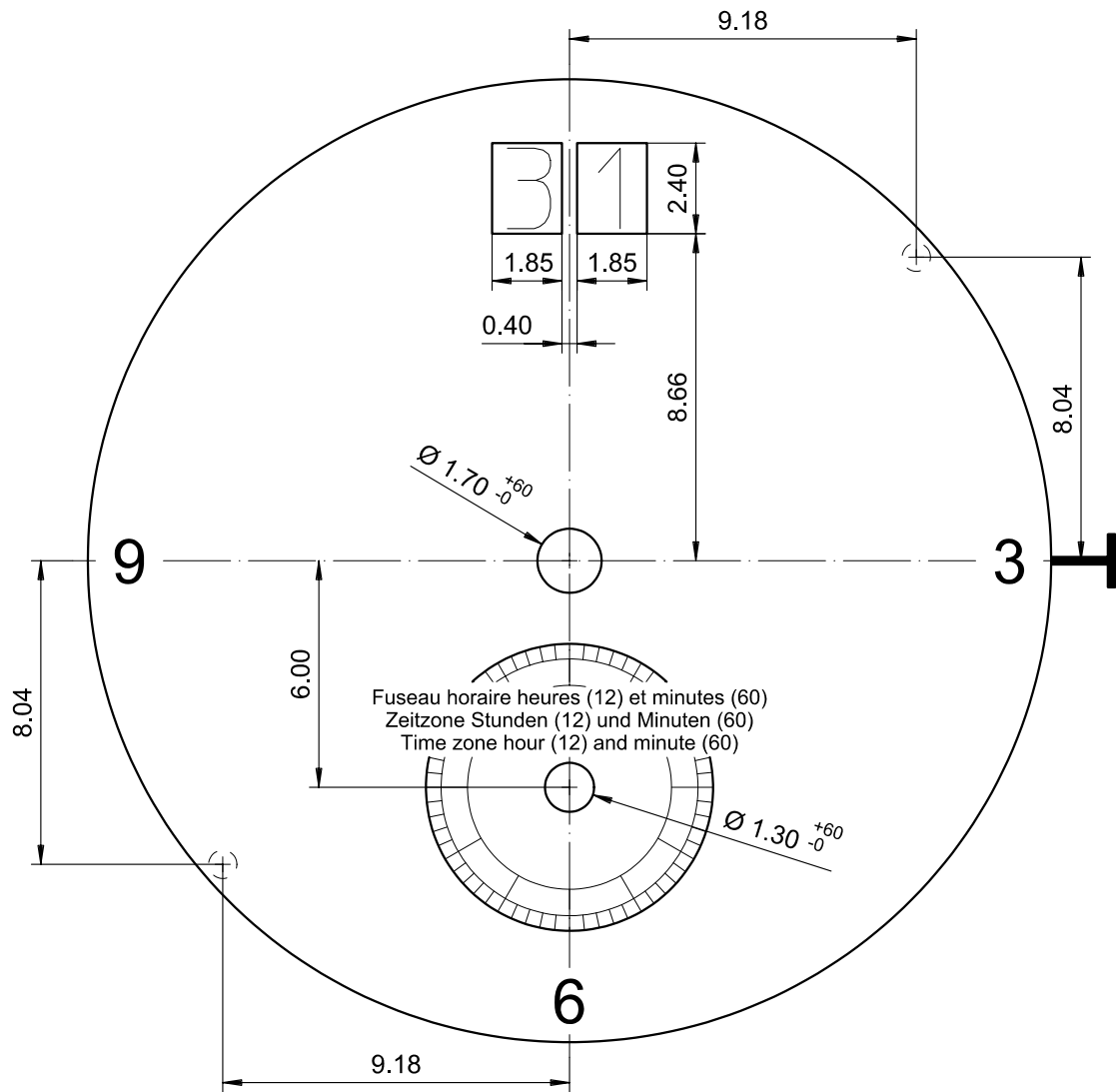

Tige	Date
Stellw.	Datum
Stem	Date
3H	12H
	<input type="checkbox"/>

Epaisseur du cadran selon hauteur de l'aiguillage
 Zifferblattdicke gemäss Zeigerwerkhöhen
 Dial thickness according to hand fitting heights

Cadran Zifferblatt Dial	11½"	Issued	06 Mai 2004	mg
		Modified	21.Apr.2008 ÄA 4553	fl
		Released	YES	
		Tolerance	+/- 20 µm	
		Scale	5 : 1 (A4V)	
RONDA	6203.B	Sous réserve de modifications Aenderungen vorbehalten Modifications reserved		
		No.	5010.797	01

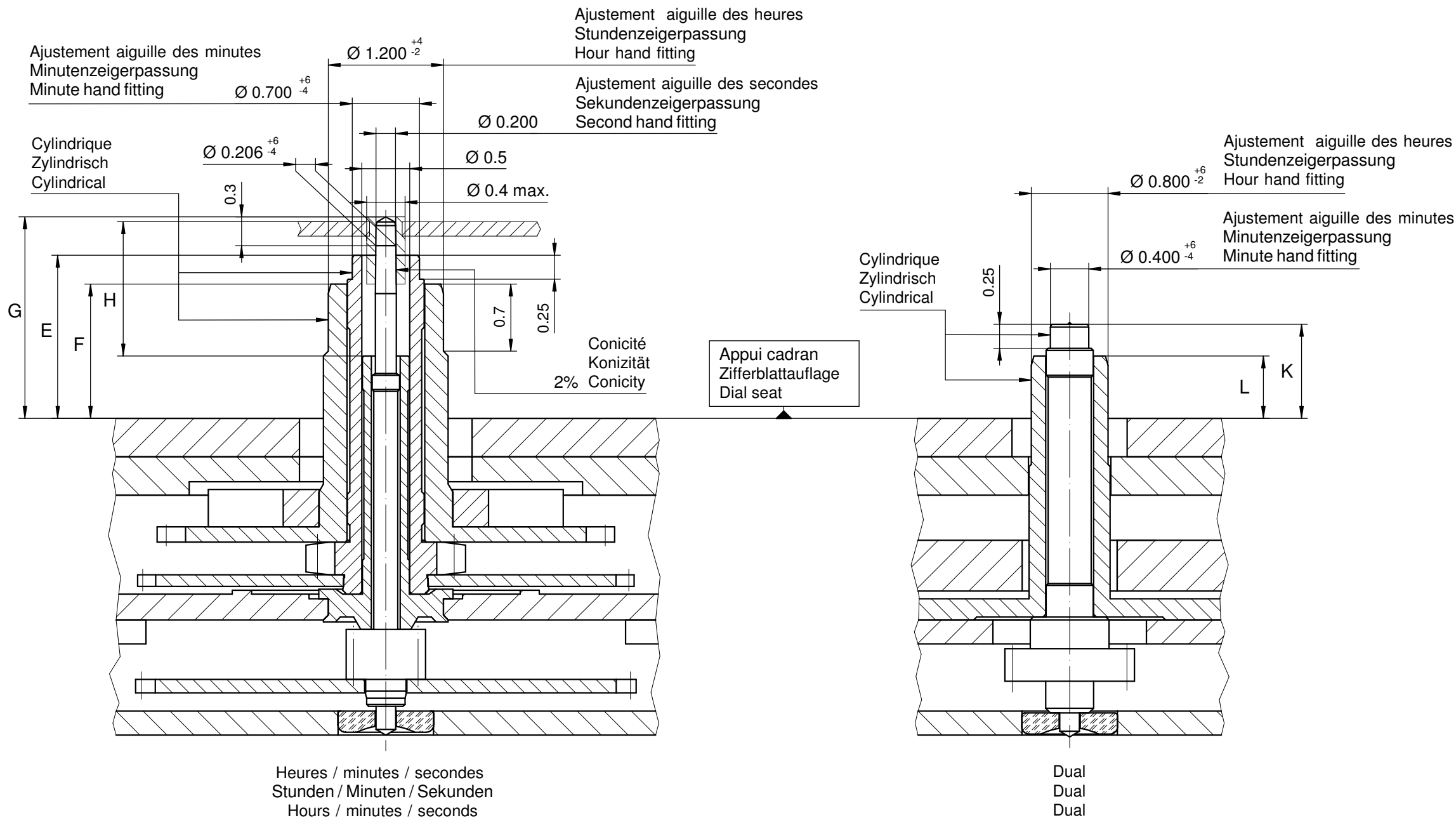

Heures / minutes / secondes
 Stunden / Minuten / Sekunden
 Hours / minutes / seconds

Dual
 Dual
 Dual

		Aig. des secondes Sekundenzeiger Second hand	Aig. des minutes Minutenzeiger Minute hand	Aig. des heures Stundenzeiger Hour hand	Dual		Lors de la pose d'aiguilles, le mouvement doit être soutenu. Beim Zeigersetzen muss das Werk abgestützt werden. The movement needs to be supported for hand setting.
					Aig. des minutes Minutenzeiger Minute hand	Aig. des heures Stundenzeiger Hour hand	
mg	max.	10	30	30	10	10	Masse / Masse / Weight *
µNm	max.	0.05	0.80	0.80	0.15	0.15	Balourd / Unwucht / Unbalance *
gmm ²	max.	0.4	-	-	-	-	Inertie / Massenträgheit / Inertia *
N	max.	30	40	40	30	30	Force de chassage / Aufpresskraft / Force

Aiguillages Zeigerwerkhöhe Hand fitting height						
Dépassement Höhe über Zifferblattaufgabe Height over dial seat						
No	Pignon des secondes Sekundentrieb Second pinion	Chaussée Minutenrohr Cannon-pinion	Roue des heures Stundenrad Hour wheel	Dual		
				Chaussée Minutenrohr Cannon-pinion	Roue des heures Stundenrad Hour wheel	
G	E	F	H	K	L	
1	2.10	1.70	1.40	1.45	0.98	0.65
2	2.30	1.90	1.60	1.65	1.18	0.88

Aiguillages Zeigerwerkhöhe Hand fitting height						
Peinture comprise / inkl. Farbe / Paint included						
Epaisseur maximum du cadran Maximale Zifferblattstärke Maximum dial thickness						
No	Sous l'aiguille des secondes Unter Sekundenzeiger Under second hand	Sous l'aiguille des minutes Unter Minutenzeiger Under minute hand	Sous l'aiguille des heures Unter Stundenzeiger Under hour hand	Dual		Epaisseur des aiguilles Zeigerdicke Hands thickness
				Sous l'aiguille des minutes Unter Minutenzeiger Under minute hand	Sous l'aiguille des heures Unter Stundenzeiger Under hour hand	
1	1.60	1.30	1.00	0.55	0.25	0.15
2	1.85	1.50	1.20	0.75	0.45	0.15

<h2>Aiguillages Zeigerwerkhöhen 11½"</h2> <h3>Hand fitting heights</h3>		Issued	05 sep 2005	fl
		Modified	11 Nov 2013 ÄÄ 13587	dh
		Released	Yes	
		Tolerance	µm	
		Scale	20 : 1 (A3H)	
<h1>RONDA</h1> <h2>6203.B</h2>		Sous réserve de modifications Änderungen vorbehalten Modifications reserved		
		No.	3316.100	08

* En cas de données différentes, veuillez contacter le service après-vente

* Bei abweichenden Werten, bitte technischen Kundendienst anfragen

* In case of different values, please contact the customer service

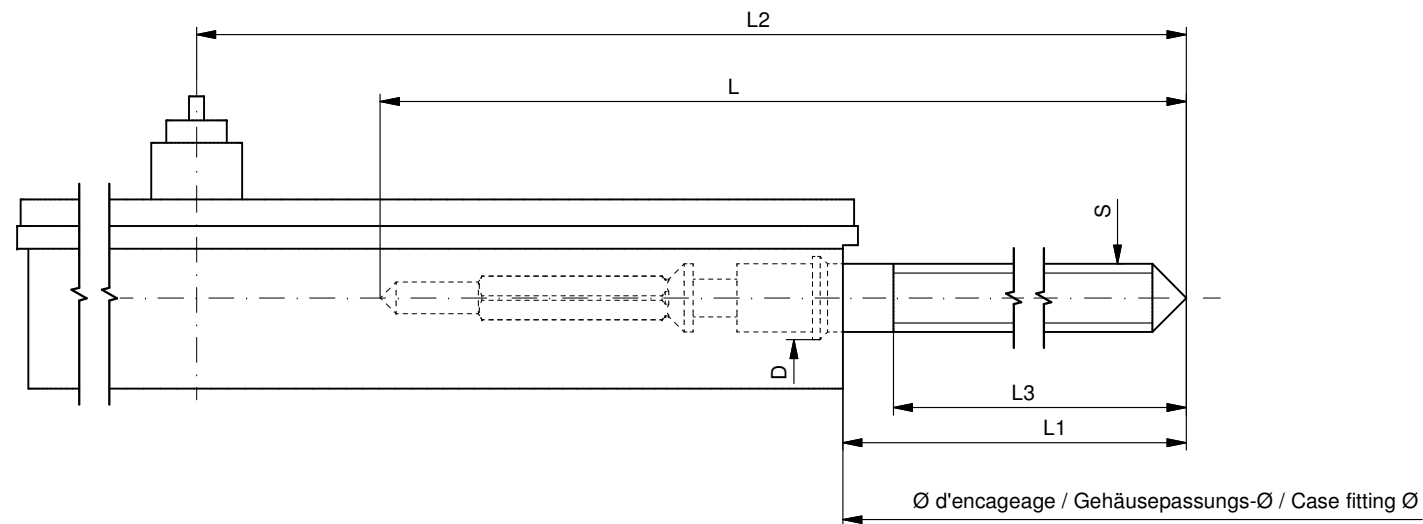

Tige de travail (intégrée dans le mouvement)
 Arbeitstellwelle (im Werk eingebaut)
 Working stem (implemented in the movement)

No. d'article Artikelnummer Part number	L	L1	L2	L3	S	D
3000.189.CO	19.30	10.57	23.37	10.15	0.90	1.10

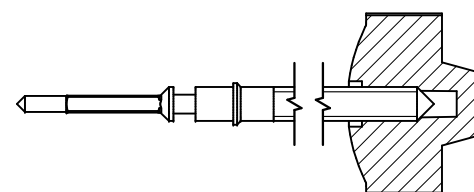

Couleur de la couronne Kronenfarbe Crown color	marron kastanienbraun chestnut
Code	UN 8018

Tige de travail dual (intégrée dans le mouvement)
 Arbeitstellwelle dual (im Werk eingebaut)
 Working stem dual (implemented in the movement)

No. d'article Artikelnummer Part number	L	L1	L2	L3	S	D
3000.190.CO	18.23	10.63	23.43	10.15	0.90	1.10

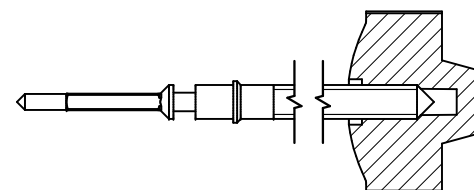

Couleur de la couronne Kronenfarbe Crown color	caramel caramel karamel
Code	UN 8035

Tige (normale) / Stellwelle (normal) / Stem (normal)

No. d'article Artikelnummer Part number	L	L1	L2	L3	S	D
3000.189	19.30	10.57	23.37	10.15	0.90	1.10
3000.199	25.00	16.27	29.07	15.85	0.90	1.10

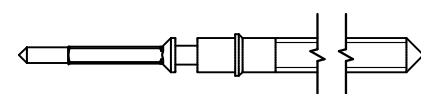

Tige dual (normale) / Stellwelle dual (normal) / Stem dual (normal)

No. d'article Artikelnummer Part number	L	L1	L2	L3	S	D
3000.190	18.23	10.63	23.43	10.15	0.90	1.10
3000.200	25.00	17.40	30.20	16.92	0.90	1.10

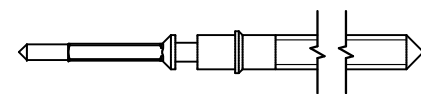

Rallonge de tige / Stellwelle Verlängerung / Stem extension

No. d'article Artikelnummer Part number	L4	L5 (min)	L6	S1	S2	D1
3000.040	12.00	1.90	2.60	0.90	0.90	1.35

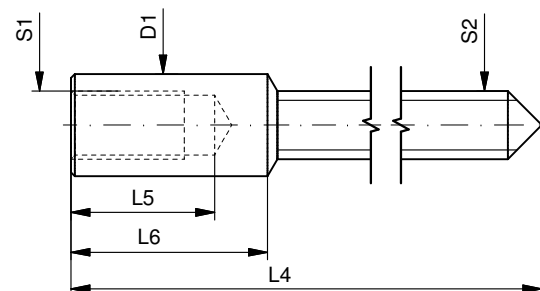

Couronne normale
 Normale Krone
 Normal crown

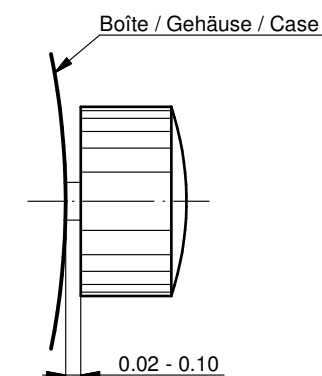

Couronne vissée
 Geschraubte Krone
 Screwed crown

Force ⇐ min. Kraft ⇐ min. Force ⇐ min.	10 N
Force ⇐ max. Kraft ⇐ max. Force ⇐ max.	15 N

Tige (dimensions / forces)
 Stellwelle (Dimensionen / Kräfte)
 Stem (dimensions / forces)

RONDA 6203.B

Issued	06 Sep 2012	ds5222
Modified	17 Mär 2017 ÄA 34582	mg5224
Released	YES	
Tolerance	---	
Scale	10:1 (A3)	

Sous réserve de modifications
 Änderungen vorbehalten
 Modifications reserved

No.	5030.020	01
-----	----------	----



Movement holder
Removing setting stem
H6XXX.1T



Movement holder
Setting hands
H6XXX.1A2



Supporting screw
Swiss Made movement holder
0.80 mm

Fitting dial and hands

- Crown in position II
- Wind crown until date 02 appears
- Crown in position III
- Wind hour hand forwards, until date changes to 03
- Remove working hand
- Fit dial
- Point all hands towards 12 o'clock
- Set time
- Crown in position II
- Set date
- Crown in position I
- Second time zone crown in position II
- Set second time zone time
- Second time zone crown in position I

Date switching duration

First and tenth digit discs

Details: See Instruction Manual



~2hrs

General Instructions

Removing the setting stem can only be effected in Pos. I.

The use of supporting screws is essential when mounting the hands.

Permitted hand setting strengths:

Hr / min. hands: <40N

Other hands: <30N

During quick date correction (setting stem in position II), a date switching speed of 5 d/s must not be exceeded.

RONDA normtech

– 6203.B

RONDA mastertech

– 7003.L

– 7003.N

– 7004.N

– 7004.P

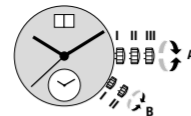

Cal. 6203.B

Crown A

Pos. I Position of rest (watch running)

Pos. II Quick-change correction for date

The date can also be corrected during the day-changing phase between 10.00 pm and midnight. The date of the following day has to be set, because no automatic date change takes place at midnight.

- Pull the crown out to position II (watch still running).
- Turn the crown clockwise until the required date appears.
- Push the crown back into position I.

Pos. III Setting the time (both time zones together)

- Pull the crown out to position III (watch stopped).
- Turn the crown, until the current time is displayed (remember the 24-hour cycle).
- Push the crown back into position I.

Cal. 6203.B

Crown B

Pos. I Position of rest

Pos. II Setting the time of the 2nd time zone

During the time setting of the 2nd time zone, crown A must be in position I.

- Pull the crown out to position II.
- Turn the crown, until the desired time is displayed.
- Push the crown back into position I.

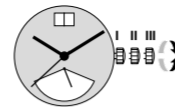

Cal. 7003.L



Cal. 7004.N

Pos. I Position of rest (watch running)

Pos. II Quick-change correction for date

The date can also be changed during the day-changing phase between approx. 8.00 pm and midnight. The date of the following day has to be set, because no automatic date change takes place at midnight.

- Pull the crown out to position II (watch still running).
- Turn the crown until the current date appears.
- Push the crown back into position I.

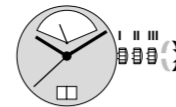

Cal. 7003.N

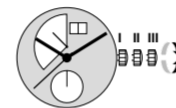

Cal. 7004.P

Pos. III Setting the time

- Pull the crown out to position III (watch stopped).
- Turn the crown, until the current time is displayed (remember the 24-hour cycle).
- Push the crown back into position I.

Setting the day of the week

There is no quick-change correction available for setting the day of the week.

- Pull the crown out to position III (watch stopped).
- Turn the hands forward by turning the crown, until the current day of the week appears.
- Push the crown back into position II and set the current date using the quick change correction.
- Push the crown back into position I.

Cal. 7003.L / 7003.N / 7004.N / 7004.P

Cal. 6203.B

Battery type: 373/SR916SW

Cal. 7003.L / 7003.N / 7004.N / 7004.P









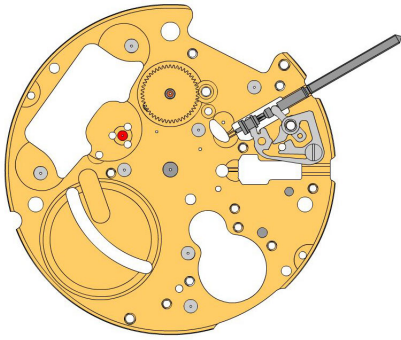
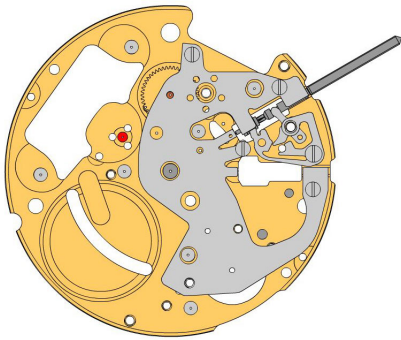
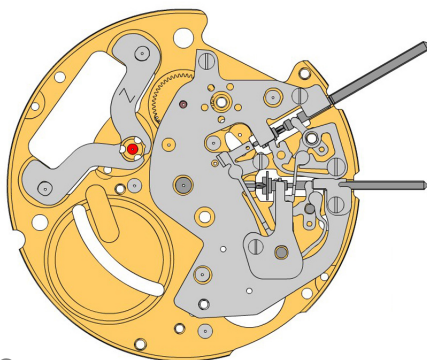







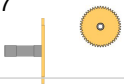

Battery type: 381/SR1120SW

Precision: +20/-10 seconds per month





You have decided to buy a watch, which was assembled by a watchmaker using a Ronda movement. Please note that no watches are produced or distributed under the Ronda brand.

In case of repairs, guarantee claims and questions concerning the functioning of a watch, purchasers and consumers should contact their retailer or the watch manufacturer, for which the relevant information can be found in the sales or guarantee documentation provided with the watch.

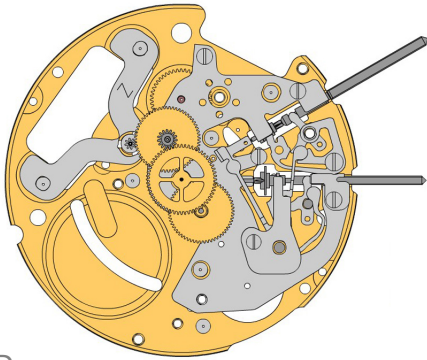



A

B

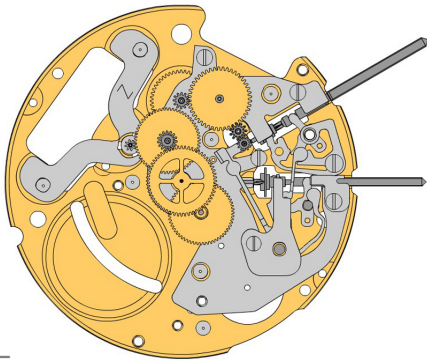
C

2000.627.G 1.		Main plate
3017.052 2.		Setting lever dual
3015.075 3.		Yoke dual Yoke dual held by 1 screw 4000.282.
4000.282 4.		Screw
3001.044 5.		Sliding pinion
3000.190.CO 6.		Handsetting stem dual
3315.018 7.		Friction spring
3301.277 8.		Hour wheel dual (Aig.1)
2130.204.CO 9.		Setting mechanism cover Setting mechanism cover tenue par 3 vis 4000.321.
4000.312 10.		Screw
3017.057 11.		Setting lever
3015.074 12.		Yoke (3 positions) Tensioning the spring arm.
3001.042.FI 13.		Sliding pinion
3000.189.CO 14.		Handsetting stem
2020.166 15.		Yoke bridge Yoke bridge held by 1 screw 4000.328.
4000.328 16.		Screw
2130.199 17.		Stem maintaining plate Stem maintaining plate held by 1 screw 4000.312.
4000.312 18.		Screw
3622.042 19.		Stator Mark Z on stator.







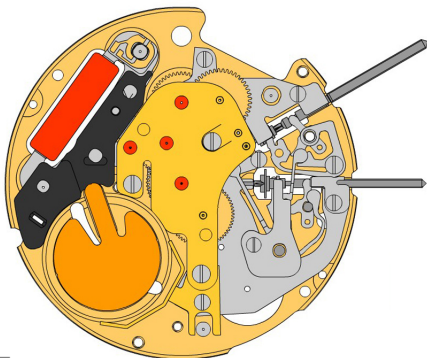

D

3715.103.RK 20.		Rotor
3147.056.CO 21.		Intermediate wheel
3122.059.CO 22.		Third wheel
3136.162.CO 23.		Center second wheel (Aig.1)

E

3305.313.FI 24.		Cannon pinion dual (Aig.1)
3004.185.CO 25.		Intermediate setting wheel dual
3004.198.FI 26.		Setting wheel dual
3007.074.CO 27.		Minute wheel dual

F

2020.180.G 28.		Train wheel bridge Train wheel bridge held by 3 screws 4000.279.
4000.279 29.		Screw
3601.117.G 30.		Battery clamp + Lateral bridle held by 1 screw 4000.244.
4000.244 31.		Screw
3621.060.RK 32.		Coil Attention: Please hold the coil only on the grey coil core.
3603.074 33.		Bridle (-) insulator
3603.075 34.		Battery insulator

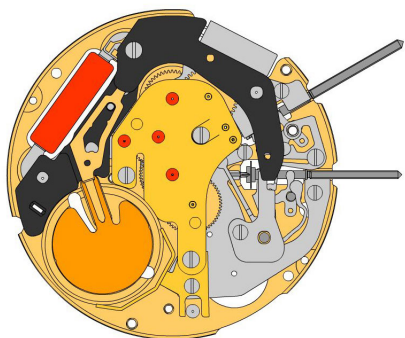

G

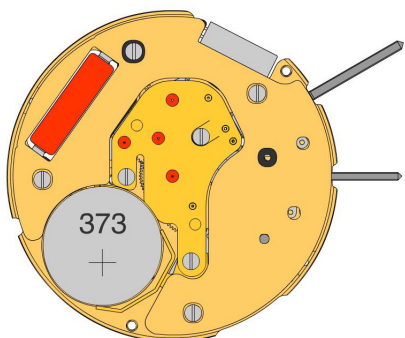

H

3601.116
35.



Bridge -
Place bridge as shown on graphics.

3612.181
36.



Electronic module
Electronic module held by 1 screw 4000.318. Electronic measurements may be realised now.

4000.318
37.



Screw

2130.168.G.M01.6203B
38.



Electronic module cover
Electronic module cover held by 3 screws 4000.102.

4000.102
39.



Screw

3600.031.HGF
40.



Battery 373

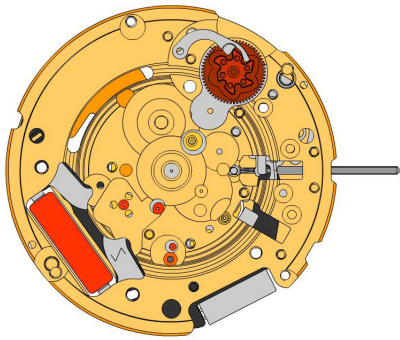



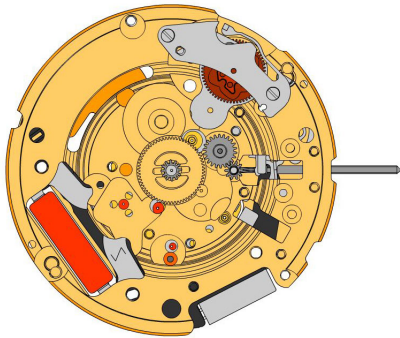



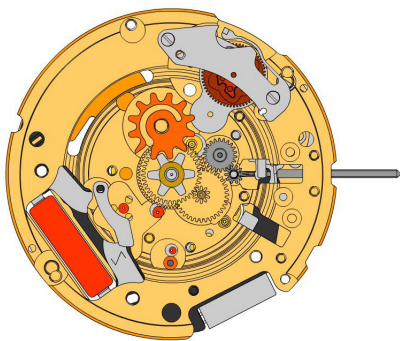





I



J



K

2000.627.G 41.		Main plate
3004.232 42.		Tens indicator driving wheel The short tooth of the tens indicator driving wheel must point to the center of the movement.
3500.060 43.		Tens jumper
2130.171 44.		Tens jumper maintaining plate Tens jumper maintaining plate held by 2 screws 4000.332. Tensioning the spring arm.
4000.332 45.		Screw
3004.182.FI 46.		Setting wheel
3004.183.FI 47.		Intermediate setting wheel
3305.308.CO 48.		Cannon pinion driving wheel (Aig.1)
3007.081.CO 49.		Minute wheel
3301.273.CO 50.		Hour wheel (Aig.1)
3315.001 51.		Friction spring
3004.187 52.		Date indicator driving wheel
3500.061 53.		Date jumper

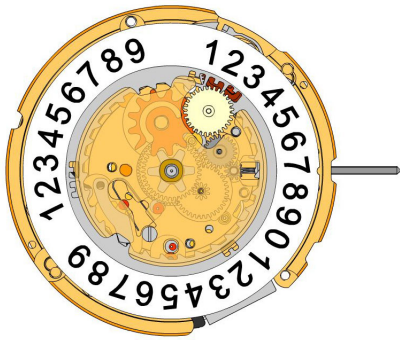

L

3504.217.AF.1.A
54.  Units indicator (standard)
Nick of the indicator at 3 o'clock.

3147.057
55.  Tens intermediate wheel

2130.169
56.  Date indicator maintaining plate
Date indicator maintaining plate held by 1 screw 4000.312.

4000.312
57.  Screw

3905.070
58.  Date jumper spring
Insert the date jumper spring in the provided opening.

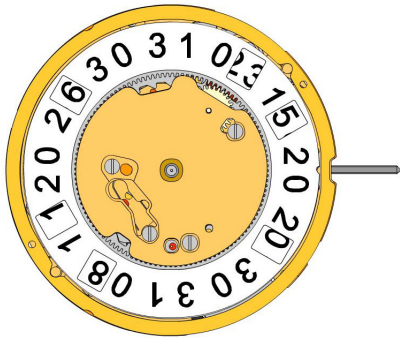

M

3504.218.AF.1.A
59.  Tens indicator (standard)
Nick of the indicator at 3 o'clock.

2130.170.G
60.  Date mechanism maintaining plate
Date mechanism maintaining plate held by 3 screws 4000.312.

4000.312
61.  Screw

3506.075.G
62.  Dial support

8200
63.  Moebius 8200

9014
64.  Moebius 9014

124
65.  Jismaa 124

9020
66.  Moebius 9020

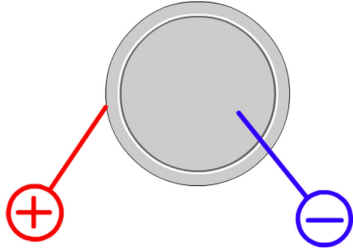

Battery	373
Voltage	1.55 V

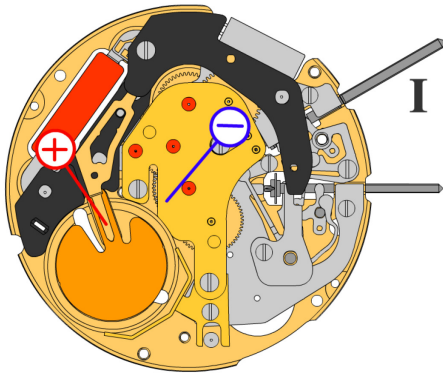

*Setting stem in position I, calendar not in gear,
60 s measuring interval for rate and consumption:*

Typical consumption	1.03 μA
Maximal consumption	1.85 μA
Instantaneous rate	-10s/M. .. +20s/M.
Lower working voltage limit	1.20 V

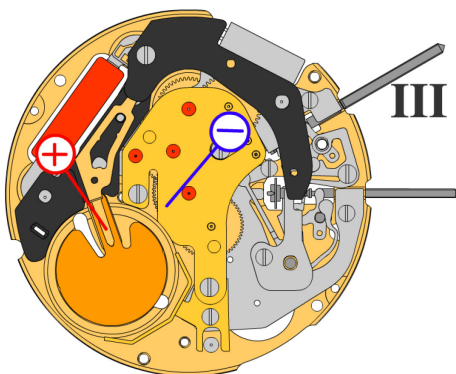

Setting stem in position III, 60 s measuring interval:

Typical consumption	0.10 μA
Maximal consumption	0.30 μA

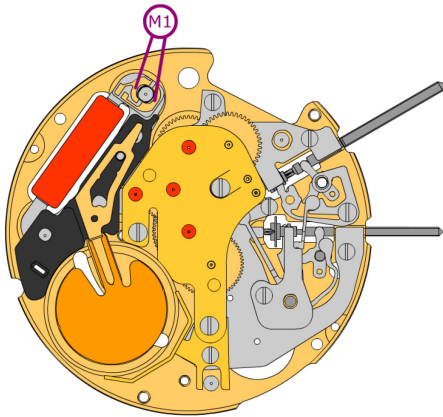

Coil resistance M1



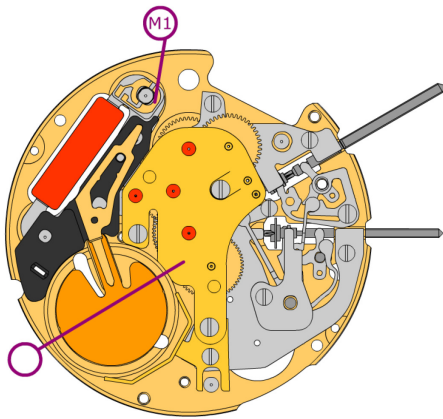



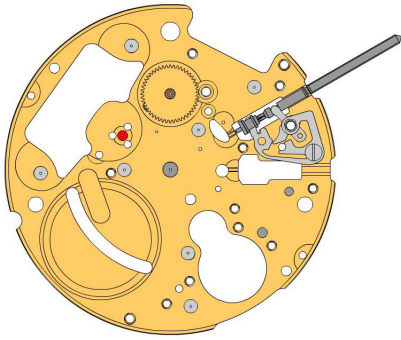
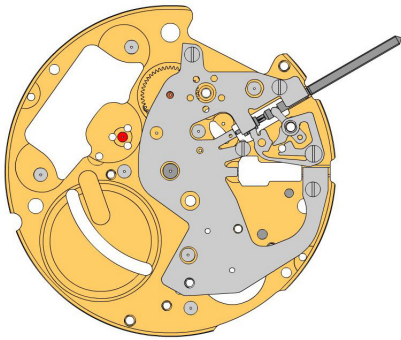
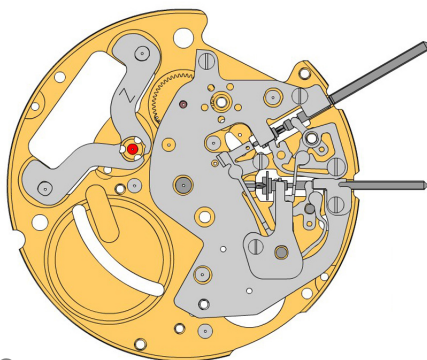

1.61 k Ω .. 1.81 k Ω













Coil isolation M1

∞ k Ω

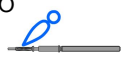



A

B

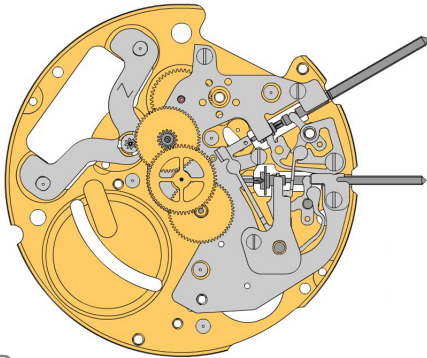
C

2000.627.G 1.		Main plate
3017.052 2.		Setting lever dual
3015.075 3.		Yoke dual Yoke dual held by 1 screw 4000.282.
4000.282 4.		Screw
3001.044 5.		Sliding pinion
3000.190.CO 6.		Handsetting stem dual
3315.018 7.		Friction spring
3301.277 8.		Hour wheel dual (Aig.1)





2130.167.CO 9.		Setting mechanism cover Setting mechanism cover tenue par 3 vis 4000.321. Parts 2130.167.CO and 3004.188 must be exchanged together.
4000.312 10.		Screw

3017.057 11.		Setting lever
3015.074 12.		Yoke (3 positions) Tensioning the spring arm.
3001.042.FI 13.		Sliding pinion
3000.189.CO 14.		Handsetting stem
2020.166 15.		Yoke bridge Yoke bridge held by 1 screw 4000.328.
4000.328 16.		Screw
2130.199 17.		Stem maintaining plate Stem maintaining plate held by 1 screw 4000.312.
4000.312 18.		Screw
3622.042 19.		Stator Mark [Z] on stator.

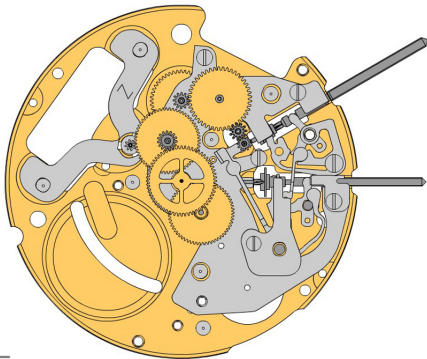





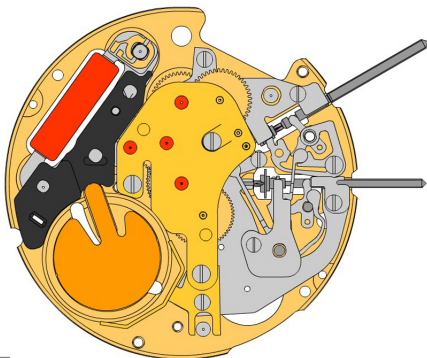

D

3715.103.RK 20.		Rotor
3147.056.CO 21.		Intermediate wheel
3122.059.CO 22.		Third wheel
3136.162.CO 23.		Center second wheel (Aig.1)

E

3305.313.FI 24.		Cannon pinion dual (Aig.1)
3004.185.CO 25.		Intermediate setting wheel dual
3004.198.FI 26.		Setting wheel dual
3007.074.CO 27.		Minute wheel dual

F

2020.180.G 28.		Train wheel bridge Train wheel bridge held by 3 screws 4000.279.
4000.279 29.		Screw
3601.117.G 30.		Battery clamp + Lateral bridle held by 1 screw 4000.244.
4000.244 31.		Screw
3621.060.RK 32.		Coil Attention: Please hold the coil only on the grey coil core.
3603.074 33.		Bridle (-) insulator
3603.075 34.		Battery insulator

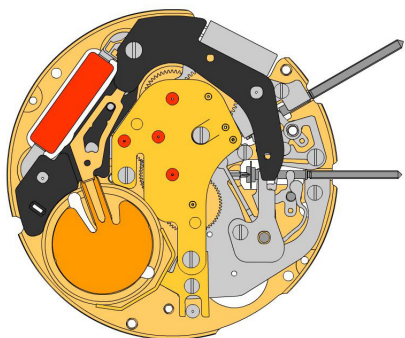
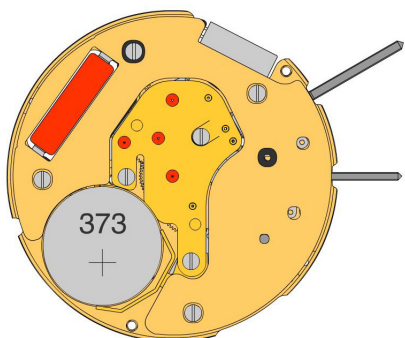
G

H
3601.116
35.

Bridle -
 Place bridle as shown on graphics.

3612.181
36.

Electronic module
 Electronic module held by 1 screw 4000.318. Electronic measurements may be realised now.

4000.318
37.

Screw
2130.168.G.M01.6203B
38.

Electronic module cover
 Electronic module cover held by 3 screws 4000.102.

4000.102
39.

Screw
3600.031.HGF
40.

Battery 373

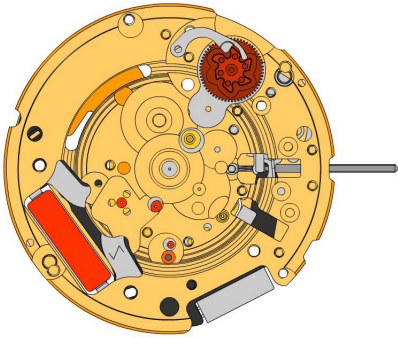

I

2000.627.G
41.  Main plate

3004.188
42.  Tens indicator driving wheel
The short tooth of the tens indicator driving wheel must point to the center of the movement. Parts 2130.167.CO and 3004.188 must be exchanged together.

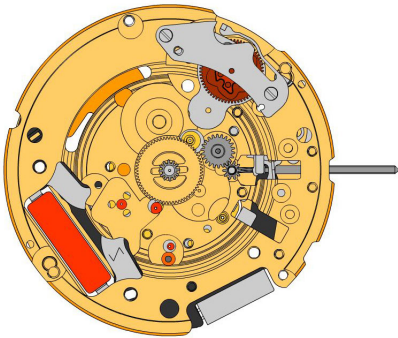
3500.060
43.  Tens jumper



J

2130.171
44.  Tens jumper maintaining plate
Tens jumper maintaining plate held by 2 screws 4000.332. Tensioning the spring arm.

4000.332
45.  Screw

3004.182.FI
46.  Setting wheel

3004.183.FI
47.  Intermediate setting wheel

3305.308.CO
48.  Cannon pinion driving wheel (Aig.1)

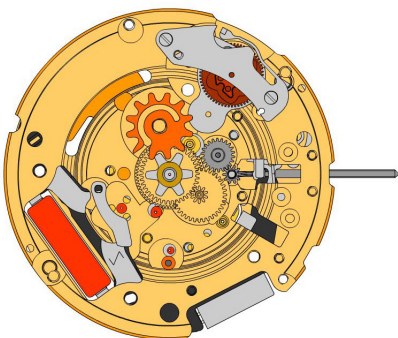
K

3007.081.CO
49.  Minute wheel

3301.273.CO
50.  Hour wheel (Aig.1)

3315.001
51.  Friction spring

3004.187
52.  Date indicator driving wheel

3500.061
53.  Date jumper

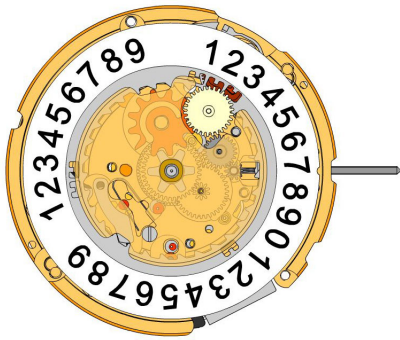

L

3504.217.AF.1.A
54.  Units indicator (standard)
Nick of the indicator at 3 o'clock.

3147.057
55.  Tens intermediate wheel

2130.169
56.  Date indicator maintaining plate
Date indicator maintaining plate held by 1 screw 4000.312.

4000.312
57.  Screw

3905.070
58.  Date jumper spring
Insert the date jumper spring in the provided opening.

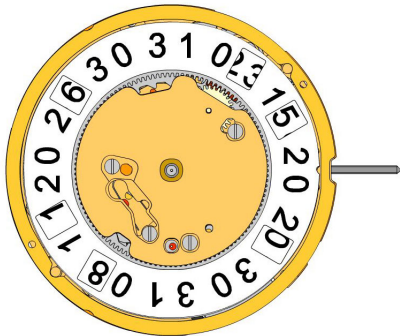

M

3504.218.AF.1.A
59.  Tens indicator (standard)
Nick of the indicator at 3 o'clock.

2130.170.G
60.  Date mechanism maintaining plate
Date mechanism maintaining plate held by 3 screws 4000.312.

4000.312
61.  Screw

3506.075.G
62.  Dial support

8200
63.  Moebius 8200

9014
64.  Moebius 9014

124
65.  Jismaa 124

9020
66.  Moebius 9020

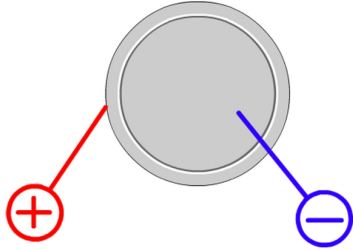

Battery	373
Voltage	1.55 V

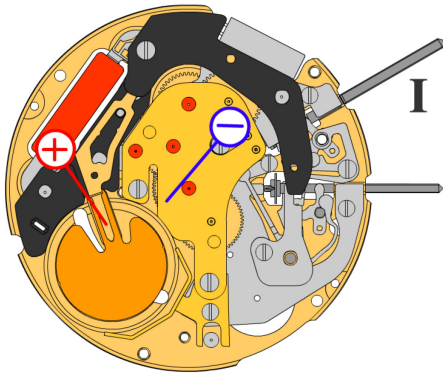

*Setting stem in position I, calendar not in gear,
60 s measuring interval for rate and consumption:*

Typical consumption	1.03 μA
Maximal consumption	1.85 μA
Instantaneous rate	-10s/M. .. +20s/M.
Lower working voltage limit	1.20 V

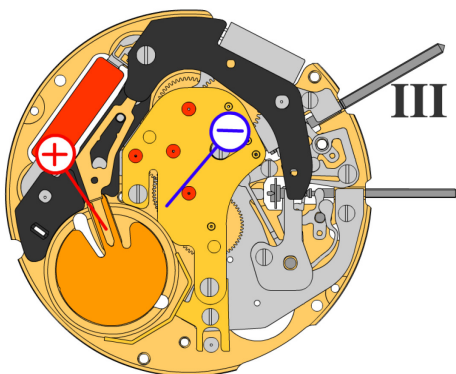

Setting stem in position III, 60 s measuring interval:

Typical consumption	0.10 μA
Maximal consumption	0.30 μA

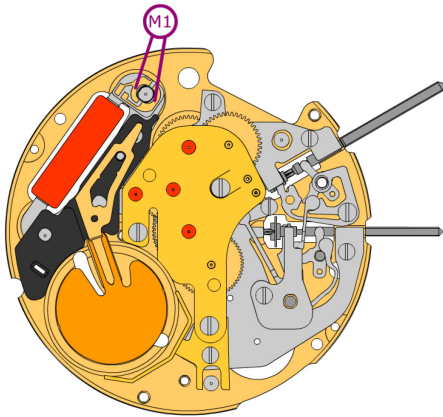

Coil resistance M1

1.61 k Ω .. 1.81 k Ω

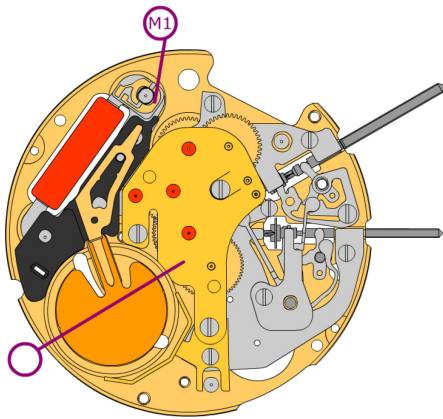

Coil isolation M1

∞ k Ω