

# RONDA startech 5000

Chronographs, Big Date & Date,  
different calendar systems, Alarm

*Caliber 5050.C – 12½'''*

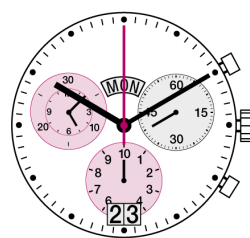
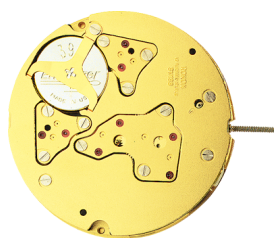
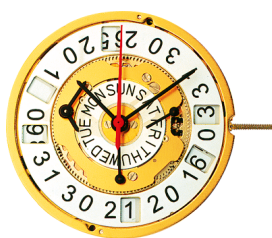

## Product Specifications

Analog quartz movement

Line	startech
Caliber	5050.C
Size	12½'''
Version	Swiss Made
	13 Jewels / gold plated
Standard battery life	54 months
Hand fitting height	2

## Features

- Repairable metal watch movement
- Very long battery life
- Power saving mechanism with pulled out stem: Reduction of consumption approximately 70%
- Very easy handling by two pushers

**Functions**

- 3 eyes
- Chronograph
- Center stop second (1/1 sec)
- 1/10 second
- 30 minute / 12 hour counter
- ADD and SPLIT functions
- Day indicator
- Big date
- Small second

**Technical Specifications**

Diameter Total	28.60 mm
Case fitting	28.00 mm
Movement height	4.40 mm
Height over standard battery	4.40 mm
Movement rest	0.60 mm
Height over stem	1.90 mm
Length of stem travel	0.90 mm
Force to push the stem for screwed crown	10 / 15 N
Stem thread	0.90 mm
Standard battery	395
Standard battery life	54 months
Battery voltage	1.5 V
Current consumption – typical	1.32 µA (Date Mechanism not in Gear)
Current consumption – maximum	1.65 µA (Date Mechanism not in Gear)
Useful torque second – typical	6 µNm
Useful torque minute – typical	300 µNm
Useful torque center stop second – typical	7 µNm
Operating temperature	0 - 50 °C
Instantaneous rate	-10/ +20 sec/month
Resistance to magnetic fields	18.8 Oe
Resistance against shock	NIHS 91-10



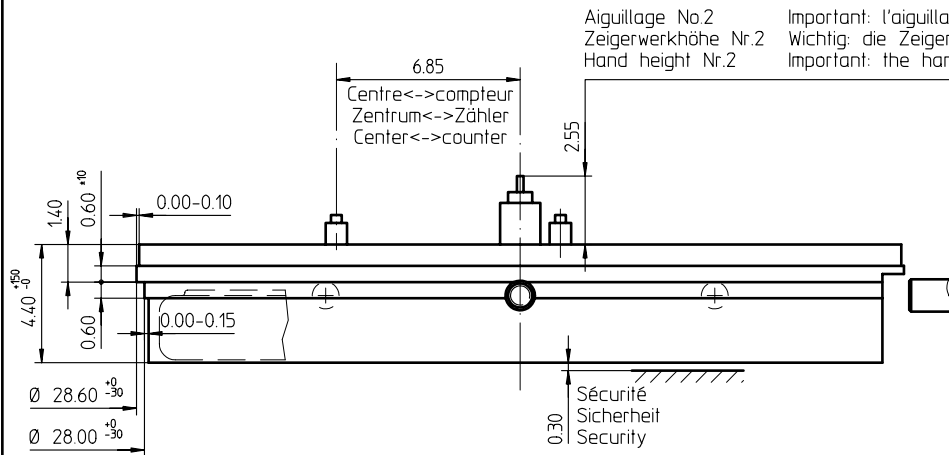

Côté fond de boîte  
Seite Gehäuseboden  
Case back side

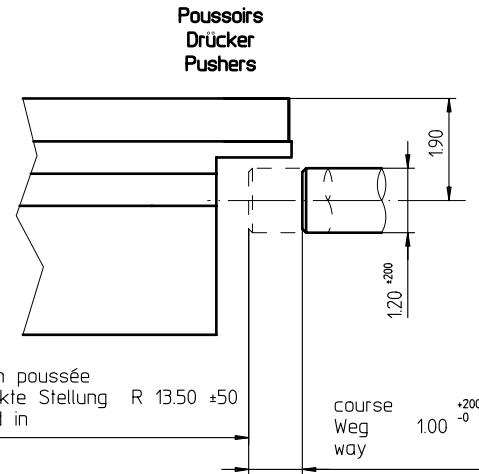

Sécurité entre l'aiguille des secondes et le verre:  
Sicherheit zwischen Sekundenzeiger und Glas: 0.30mm  
Security between second hand and glass:

Le cadran doit être tenu par la boîte  
Das Zifferblatt muss durch die Schale gehalten werden  
The dial must be hold by the case

La course du poussoir doit être limitée dans le poussoir lui-même. Sa position poussée doit être contrôlée.  
Die Weglänge des Drückers ist im Drücker selbst zu begrenzen. In der gedrückten Stellung ist seine Position zu kontrollieren  
The way of the pusher has to be limited in the pusher itself. Its position must be checked while pushed in.

Pile  
Batterie (395) Ø 9.50 x 2.60mm  
Battery

Position pour extraire la tige  
Position zum Entfernen der Stellwelle  
Position to remove the stem

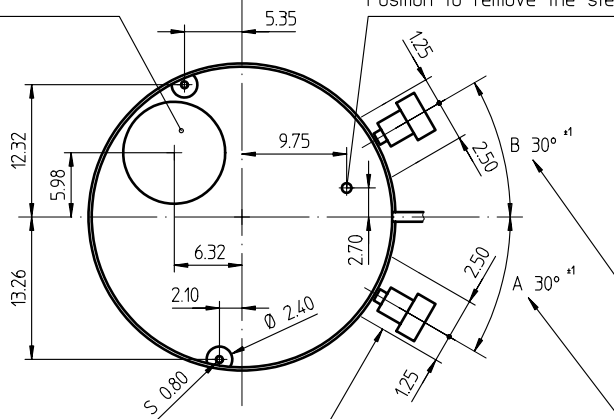

Dégagement cercle d'entourage  
Freistellung Gehäuseering  
Opening movement holder

L'angle indiqué pour la direction du poussoir et la position doivent être respectés. Pour un angle de 0° des poussoirs A et B, voir plan 5000.345  
Der angegebene Winkel für die Drückerrichtung und die Position müssen eingehalten werden. Für einen Drückerwinkel von 0° bei A und B, siehe Zeichnung 5000.345  
The indicated angle of the pusher direction and the position must be fulfilled. For pusher angles of 0° (pusher A and B), see drawing 5000.345

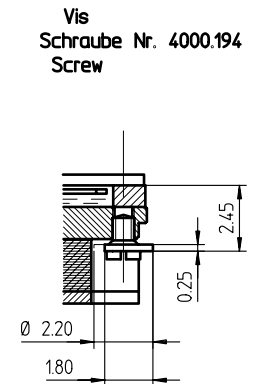
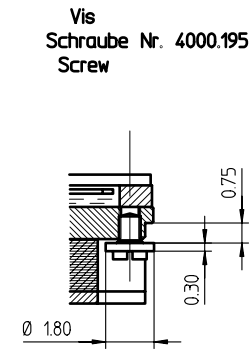
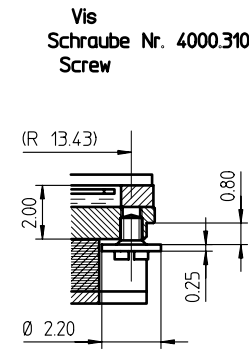
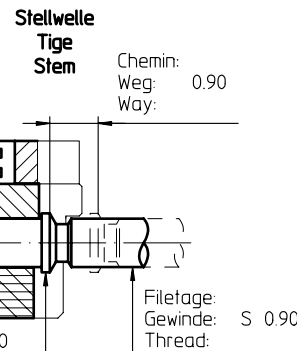

Cage  
Uhrwerkgestell  
Frame

12½"

RONDA

5050.B, 5050.C, 5051.C

Issued	14 Nov 2003	mk
Modified	10. Dez 2007 AA 3696	bk
Released	YES	
Tolerance	+/- 20 µm	
Scale	10 : 1 (5 : 1) (A3H)	

Sous réserve de modifications  
Änderungen vorbehalten  
Modifications reserved

No. 5000.319 03

Angle Winkel Angle		30°
Ø Dp	b	
1.00	13.50	
1.10	13.50	
1.20	13.50	
1.30	13.50	
1.40	13.50	

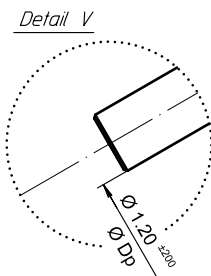
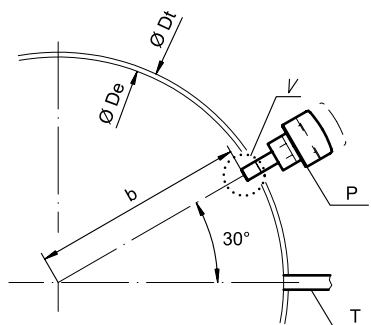

Angle Winkel Angle			0°
Ø Dp	a	b	
1.30	7.40	11.43	
1.40	7.45	11.40	

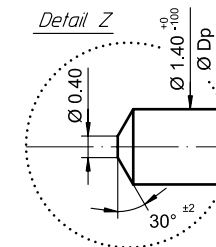
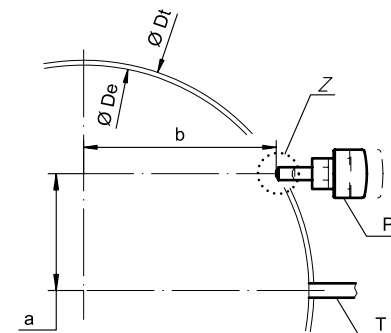

Angle Winkel Angle			20°
Ø Dp	a	b	
1.30	2.57	13.22	
1.40	2.59	13.21	

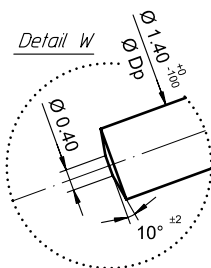
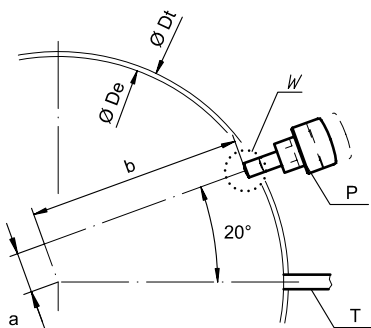

Ø De: diamètre d'encastage  
Durchmesser der Gehäusepassung  
fitting-diameter

Ø Dp: diamètre du poussoir  
Drückerdurchmesser  
pusher-diameter

Ø Dt: diamètre total  
Totaldurchmesser  
total-diameter

P: poussoir en position poussée  
Drücker in gedrückter Stellung  
pusher in pressed position

T: tige de mise à l'heure  
Stellwelle  
stem

Angle Winkel Angle			15°
Ø Dp	a	b	
1.30	3.83	12.92	
1.40	3.86	12.91	

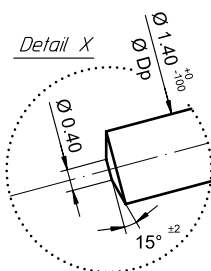
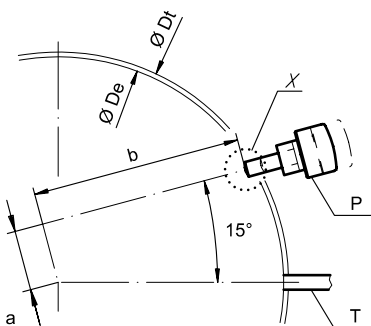

Angle Winkel Angle			10°
Ø Dp	a	b	
1.30	5.06	12.52	
1.40	5.10	12.50	

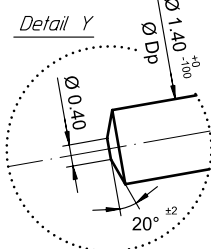
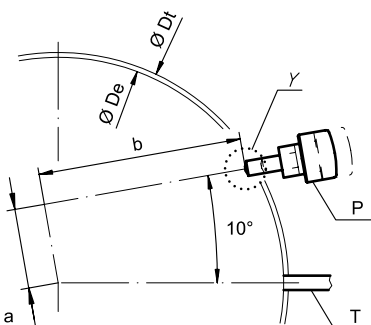

Angle des poussoirs A et B  
Winkel der Drücker A und B  
Angle of pusher A and B

RONDA

4xxx.x, 5xxx.x

Issued	06 Sep 2004	mk
Modified	30. März 2005 ÄÄ 1784	mk
Released	YES	
Tolerance	+/- 20 µm	
Scale	10 : 1 (5 : 1) (A3H)	

Sous réserve de modifications  
Änderungen vorbehalten  
Modifications reserved

No.	5000.345	01
-----	----------	----

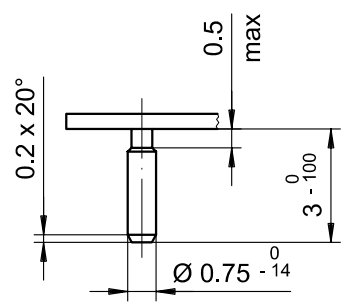
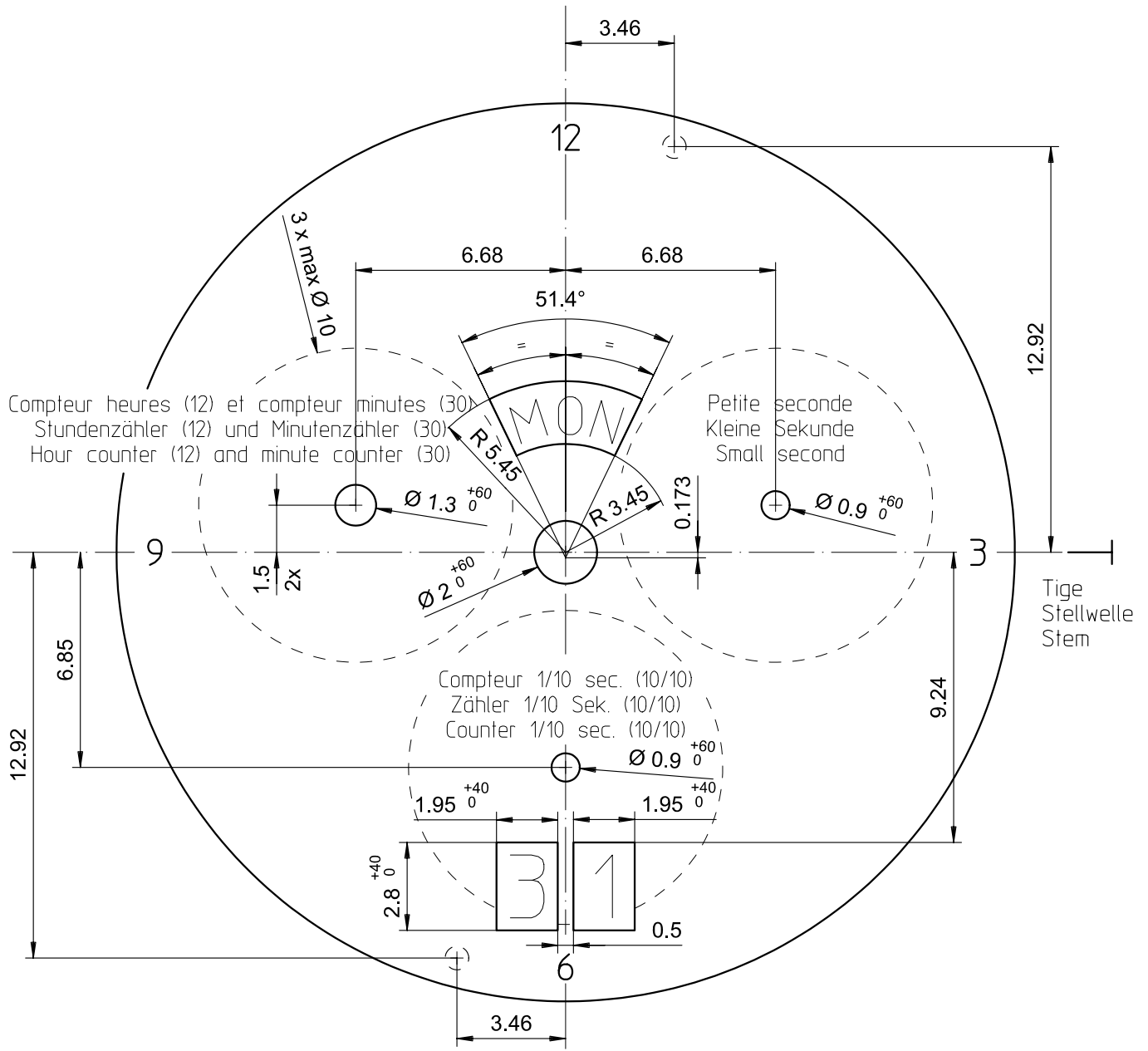

Epaisseur du cadran selon hauteur de l'aiguillage  
 Zifferblattdicke gemäss Zeigerwerkhöhen  
 Dial thickness according to hand fitting heights

Tige	Date
Stellw.	Datum
Stem	Date
<b>3H</b>	<b>6H</b>
	<input type="checkbox"/>

<b>Cadran</b> <b>Zifferblatt</b> <b>Dial</b>	<b>12 1/2"</b>	Issued	14 Nov 2003	mk
		Modified	15 Juni 2009 ÄA 6896	dh
		Released	YES	
		Tolerance	+/- 20 µm	
		Scale	5 : 1 (A4V)	
<b>RONDA</b>	<b>5050.C</b>	Sous réserve de modifications Aenderungen vorbehalten Modifications reserved		
		No.	5010.700	03



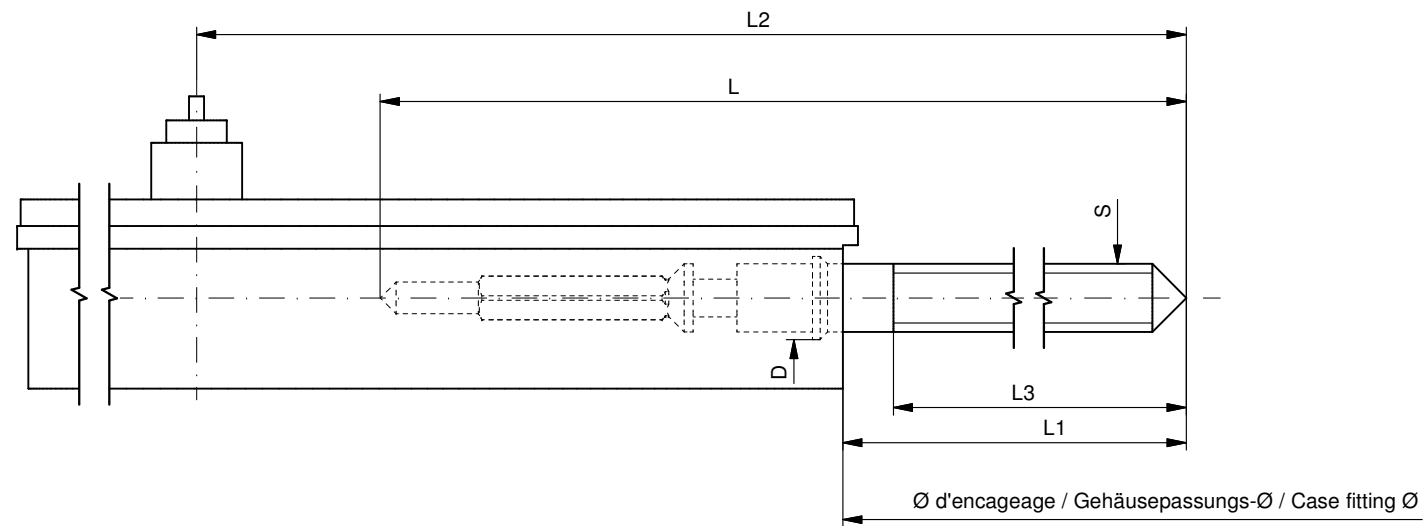

Tige de travail (intégrée dans le mouvement)  
 Arbeitstellwelle (im Werk eingebaut)  
 Working stem (implemented in the movement)

No. d'article Artikelnummer Part number	L	L1	L2	L3	S	D
3000.177.CO	20.00	10.23	24.23	10.15	0.90	1.10

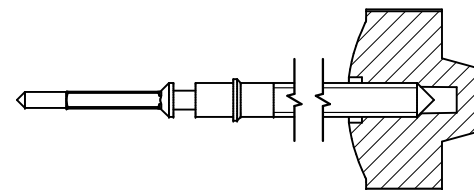

Couleur de la couronne Kronenfarbe Crown color	bleu foncé dunkelblau dark blue
Code	UN 5002

Tige (normale) / Stellwelle (normal) / Stem (normal)

No. d'article Artikelnummer Part number	L	L1	L2	L3	S	D
3000.177	20.00	10.23	24.23	10.15	0.90	1.10
3000.191	32.00	22.23	36.23	22.15	0.90	1.10

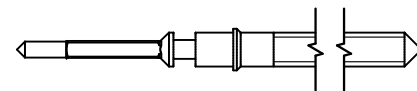

Couronne normale  
 Normale Krone  
 Normal crown

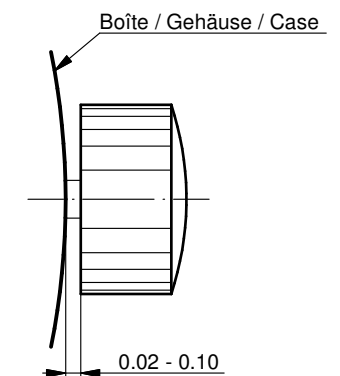

Couronne vissée  
 Geschraubte Krone  
 Screwed crown

Force ⇐ min. Kraft ⇐ min. Force ⇐ min.	10 N
Force ⇐ max. Kraft ⇐ max. Force ⇐ max.	15 N

Rallonge de tige / Stellwelle Verlängerung / Stem extension

No. d'article Artikelnummer Part number	L4	L5 (min)	L6	S1	S2	D1
3000.040	12.00	1.90	2.60	0.90	0.90	1.35

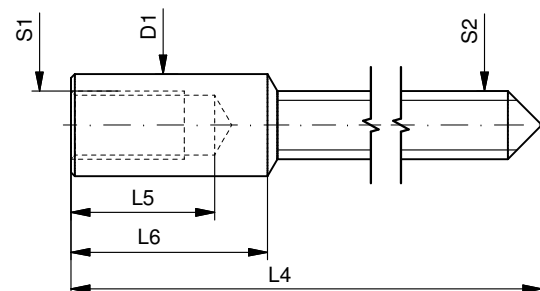

Tige (dimensions / forces)  
 Stellwelle (Dimensionen / Kräfte)  
 Stem (dimensions / forces)

**RONDA**

5010.B, 5020.B, 5021.D, 5030.D,  
 5040.B, 5040.D, 5040.E, 5040.F,  
 5050.B, 5050.C, 5051.C, 5130.B, 5130.D

Issued	05 Sep 2012	ds5222
Modified	17 Mär 2017 ÄA 34582	mg5224
Released	YES	
Tolerance	---	
Scale	10:1 (A3)	

Sous réserve de modifications  
 Änderungen vorbehalten  
 Modifications reserved

No.	5030.019	01
-----	----------	----



**Movement holder**  
Removing setting stem  
H5XXX.1T



**Movement holder**  
Setting hands  
H5XXX.1A

**Fitting dial and hands**

- Crown in position II
- Wind crown, until date 02 appears
- Crown in position III
- Wind hour hand forwards, until date changes to 03
- Remove working stem
- Fit dial
- Point all hands towards 12 o'clock
- Set time
- Wind hands forwards, until actual weekday and time are displayed
- Zero chronograph hand\*
- Crown in pos. II
- Set date
- Crown in position I

**Date switching duration**

First and tenth digit discs  
Weekday

~2hrs  
~3½hrs

**\*Zeroing the Chronograph hand**

- Activate pushers A and B for 2 seconds at the same time  
(Chrono seconds hand rotates once)
- Pusher A → to correct chrono seconds hand
- Pusher B → to jump to hour hand
- Pusher A → to correct hand position
- Pusher B → to jump to minute hand
- Pusher A → to correct hand position

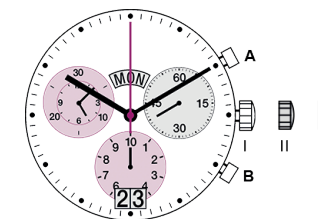
**General Instructions**

Removing the setting stem can only be effected in Pos. I.

The use of supporting screws is essential when mounting the hands.

Permitted hand setting strengths:

Hr / min. hands: <40N

Other hands: <30N

During quick date correction (setting stem in position II), a date switching speed of 5 d/s must not be exceeded.

**Weekday setting tip**

In order to avoid damage, the weekday disc should only be set with the setting stem in position III.

You have decided to buy a watch, which was assembled by a watchmaker using a Ronda movement. Please note that no watches are produced or distributed under the Ronda Brand.

**In case of repairs, guarantee claims and questions concerning the functioning of a watch, purchasers and consumers should contact their retailer or the watch manufacturer, for which the relevant information can be found in the sales or guarantee documentation provided with the watch.**

**Description of the display and control buttons**

Display elements 5050.C

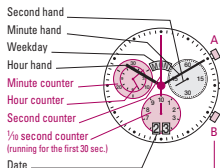

Control buttons  
 Push-button A & B  
 01 Crown

Display elements 5051.C

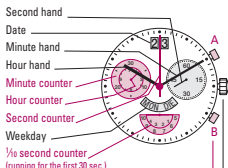

Control buttons  
 Push-button A & B  
 Crown

01

**Chronograph: Basic function**

(Start / Stop / Reset)

Example:

1 Start: Press push-button A.

2 Stop: to stop the timing, press push-button A once more and read the chronograph counters:  
 4h / 20 min / 38 sec / 7/10 sec

3 Zero positioning: Press push-button B. (The chronograph hands will be reset to their zero positions.)

05

**Chronograph: Accumulated timing**

Example:

1 Start: (start timing)

2 Stop: (e.g. 15 min 5 sec following 1)

3 Restart: (timing is resumed)

4 Stop: (e.g. 5 min 12 sec following 3) = 20 min 17 sec  
 (The accumulated measured time is shown)

5 Reset: The chronograph hands are returned to their zero positions.

Please note:

\* Following 4, the accumulation of the timing can be continued by pressing push-button A (Restart / Stop, Restart / Stop, ...).

06

**Chronograph: Intermediate or interval timing**

Example:

1 Start: (start timing)

2 Display interval: e.g. 20 minutes 17 seconds (timing continues in the background)

3 Making up the measured time: (the chronograph hands are quickly advanced to the ongoing measured time).

4 Stop: (Final time is displayed)

5 Reset: The chronograph hands are returned to their zero position

Please note:

\* Following 4, further intervals or intermediates can be displayed by pressing push-button B (display interval / make up measured time, ...).

07

**Setting the time**

1 Pull out the crown to position III (the watch stops).

2 Turn the crown until you reach the correct time 8:45.

3 Push the crown back into position I.

Please note:

\* In order to set the time to the exact second, 1 must be pulled out when the second hand is in position «60». Once the hour and minute hands have been set, 2 must be pushed back into position I at the exact second.

02

**Adjusting the chronograph hands to zero position**

Example:

One or several chronograph hands are not in their correct zero positions and have to be adjusted (e.g. following a battery change).

1 Pull out the crown to position III (all chronograph hands are in their correct or incorrect zero position).

2 Keep push-buttons A and B depressed simultaneously for at least 2 seconds (the second counter hand rotates by 360° → corrective mode is activated).

03

**Setting the date (quick mode)**

1 Pull out the crown to position II (the watch continues to run).

2 Turn the crown until the correct date 11 appears.

3 Push the crown back into position I.

Please note:

During the date changing phase between approx. 9 PM and 12 PM, the date must be set to the date of the following day.

An extreme acceleration in setting the date with quick mode can induce a false date indication. The synchronization is re-established by setting the date from 01 till 31 (crown in position II).

04

**Setting the date, weekday and time**

Example:

- Date / time on the watch: 17 / 01:25

- Present date / time: 23 / 20:30

1 Pull out the crown to position III (the watch stops).

2 Turn the crown until yesterday's weekday 27 appears.

3 Push the crown to position II.

4 Turn the crown until yesterday's date appears 22.

5 Pull out the crown to position III (the watch stops).

6 Turn the crown until the correct date 23 and weekday 27 appears.

7\*\* Continue to turn the crown until the correct time 8:30 PM appears.

8 Push the crown back into position I.

Please note:

\* To set your watch to the exact second, please refer to the chapter entitled «setting the time».

\*\* Please observe the AM/PM clock rhythm.

04

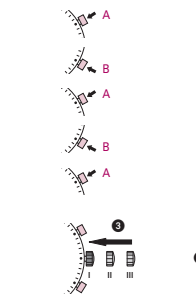

**Adjusting the second counter hand**

Single step: A 1 x short  
 Continuous: A long

**Adjusting the next hand B**

Single step: A 1 x short  
 Continuous: A long

**Adjusting the 1/2 second counter hand (position 6h)**

Single step: A 1 x short  
 Continuous: A long

**Adjusting the minute counter hand and the hour counter hand (mechanical coupled)**

Single step: A 1 x short  
 Continuous: A long

3 Returning the crown to position I

Termination of the chronograph hands adjustment (can be carried out at any time).

08



Battery type: 395 / SR927SW  
 Accuracy: +20 / -10 seconds per month

07/2017



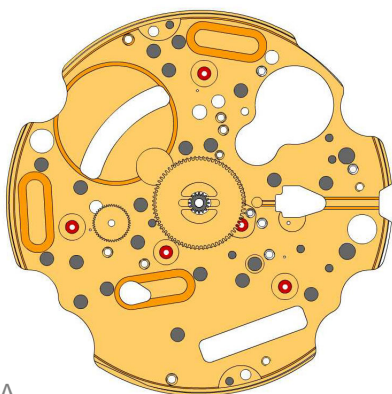



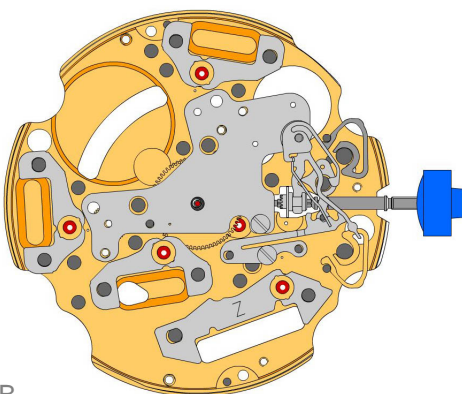





















A

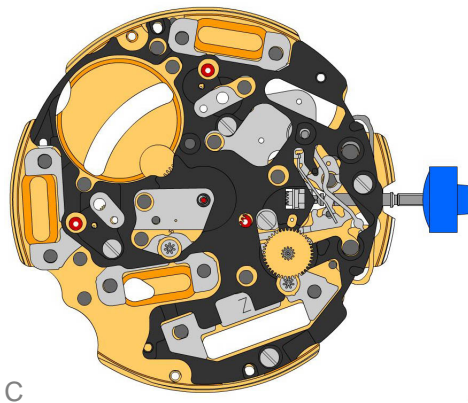





B

2000.574.G 1.		Main plate
3305.282.CO 2.		Cannon pinion with driver (Aig.2)
3301.244 3.		Hour wheel (counter 24h)
2030.032.CO 4.		Centre bridge Centre bridge held by 1 screw 4000.250.
4000.250 5.		Screw
3001.055.FI 6.		Sliding pinion
3000.177.CO 7.		Setting stem
3017.049 8.		Setting lever
3905.049 9.		Setting lever jumper (3 positions) Setting lever jumper held by 1 screw 4000.250.
3015.081 10.		Yoke (3 positions) Parts 3015.081 and 3905.067 must be exchanged together.
3905.067 11.		Yoke spring Tensioning the spring arm.
3406.030 12.		Pusher jumper B Put the grey jumper between the two posts on the further side.
3406.038 13.		Pusher jumper A Put the yellow jumper between the two posts on the closer side.
3622.040 14.		Stator Mark [Z] on stator.
3622.039 15.		Stator (counter 6h, 9h, chrono)
3622.039 16.		Stator (counter 6h, 9h, chrono)
3622.039 17.		Stator (counter 6h, 9h, chrono)
4000.250 18.		Screw

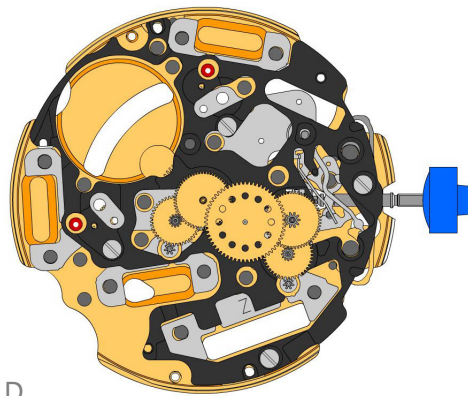



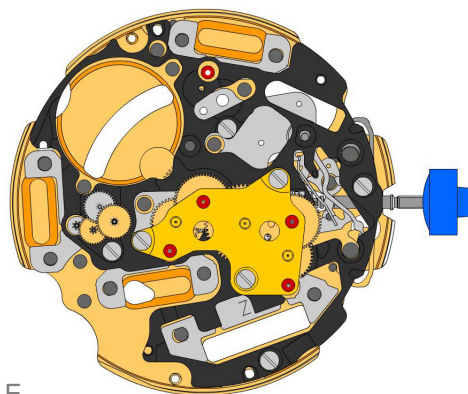

**C**

3603.079 19.		<b>Plastic bracket</b> Plastic bracket held by 4 screws 4000.250.
4000.250 20.		<b>Screw</b>
3715.094.RK 21.		<b>Rotor</b>
3715.094.RK 22.		<b>Rotor</b>
3147.046.CO 23.		<b>Intermediate wheel</b>

**D**





3136.142.CO 24.		<b>Second wheel (long)</b>
3147.047.CO 25.		<b>Intermediate wheel (chrono)</b>
3136.144.CO 26.		<b>Chronograph wheel (Aig.2)</b>
3122.056.CO 27.		<b>Third wheel</b>

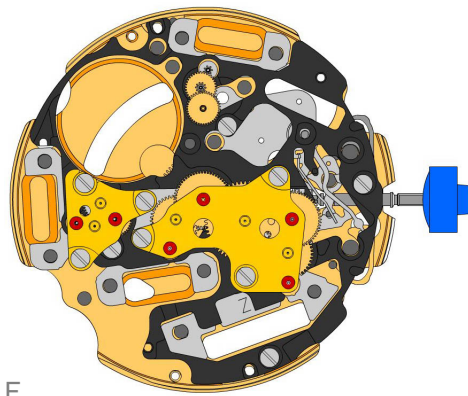

**E**

2020.148.G 28.		<b>Train wheel bridge</b> Train wheel bridge held by 3 screws 4000.250.
4000.250 29.		<b>Screw</b>
3715.095.RK 30.		<b>Rotor</b>
3147.048.CO 31.		<b>Intermediate wheel (counter)</b>
3007.056.CO 32.		<b>Minute wheel (counter 24h)</b>
3402.008.CO 33.		<b>Minute counting wheel</b>





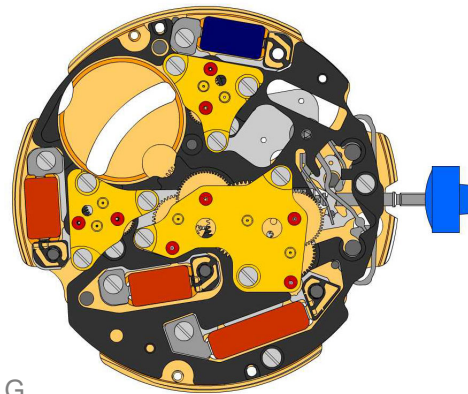





F

2020.149.G 34.		<b>Counter train wheel bridge</b> Counter train wheel bridge held by 3 screws 4000.250.
4000.250 35.		<b>Screw</b>
3715.095.RK 36.		<b>Rotor</b>
3147.053.CO 37.		<b>Intermediate wheel (counter 1/10sec)</b>
3402.016.CO 38.		<b>Counting wheel 1/10 sec</b>





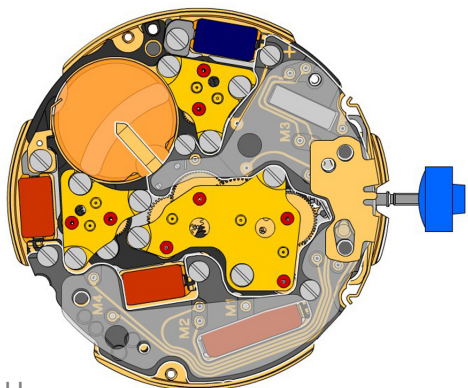

G

2020.149.G 39.		<b>Counter train wheel bridge</b> Counter train wheel bridge held by 3 screws 4000.250.
4000.250 40.		<b>Screw</b>
3621.053.RK 41.		<b>Coil</b> Attention: Please hold the coil only on the grey coil core. Coil held by 1 screw 4000.250.
3621.054.RK 42.		<b>Coil (counter 9h, chrono)</b> Attention: Please hold the coil only on the grey coil core. Coil held by 1 screw 4000.250.
3621.054.RK 43.		<b>Coil (counter 9h, chrono)</b> Attention: Please hold the coil only on the grey coil core. Coil held by 1 screw 4000.250.
3621.055.RK 44.		<b>Coil (counter 6h)</b> Attention: Please hold the coil only on the grey coil core. Coil held by 1 screw 4000.250.
4000.250 45.		<b>Screw</b>
3601.118 46.		<b>Contact strip</b> Contact strip tenue par 1 vis 4000.
3603.034 47.		<b>Battery insulator</b> Contact strip held by 1 screw 4000.250.



H

3612.144.5050 48.		<b>Electronic module</b> Electronic module held by 5 screws 4000.248. Electronic measurements may be realised now.
4000.248 49.		<b>Screw</b>
3603.069 50.		<b>Circuit insulator</b>
3601.107.G 51.		<b>Pusher contact spring</b>

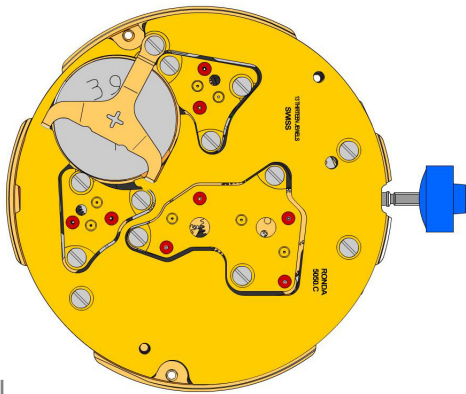









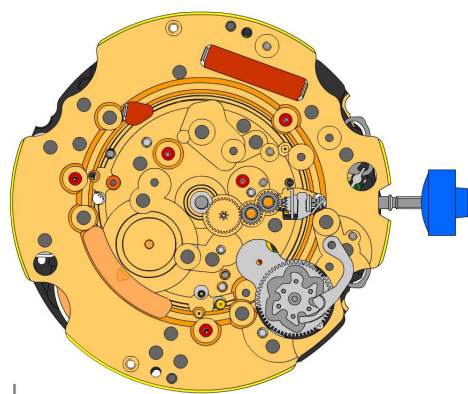
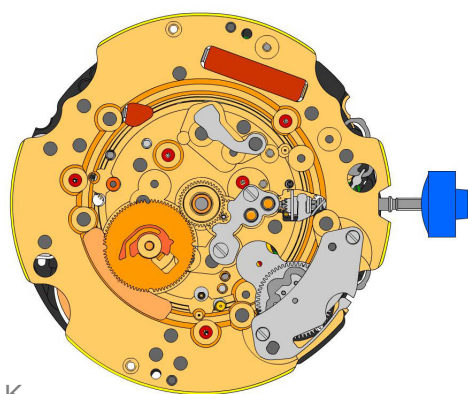





2130.137.G.M01.5050C  
52.  **Electronic module cover**  
Electronic module cover held by 3 screws 4000.250.

3600.010.HGF  
53.  **Battery 395**





3601.109.G  
54.  **Bridge +**  
Bridge held by 1 screw 4000.250.



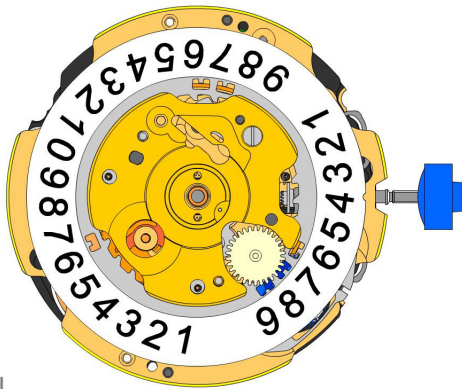
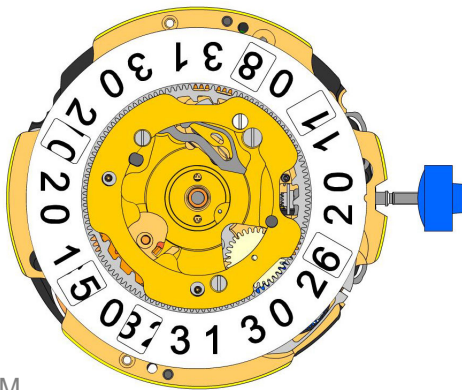
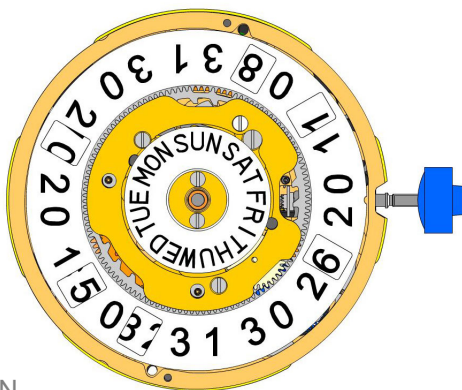

4000.250  
55.  **Screw**









**J**

**K**





2000.574.G 56.		Main plate
3004.164 57.		Setting wheel
3004.164 58.		Setting wheel
3007.054.CO 59.		Minute wheel
2130.143 60.		Minute train bridge Minute train bridge held by 2 screws 4000.305.
4000.305 61.		Screw
3004.227 62.		Tens indicator driving wheel Parts 3004.227 and 3500.75 must be exchanged together. The short tooth of the tens indicator driving wheel must point to the center of the movement.
3500.075 63.		Tens jumper Parts 3004.227 and 3500.75 must be exchanged together.
2130.142 64.		Tens jumper maintaining plate Tensioning the spring arm. Tens jumper maintaining plate held by 2 screws 4000.306.
4010.306 65.		Screw
3301.242 66.		Hour wheel (Fig.2)
3315.016 67.		Friction spring
3004.224.CO 68.		Date indicator driving wheel
3500.049 69.		Date jumper



**L**

**M**

**N**

3504.214.AD.1.A 70.		<b>Units indicator (standard)</b> Nick of the indicator at 3 o' clock.
3147.054 71.		<b>Tens intermediate wheel</b>
2130.163 72.		<b>Date indicator maintaining plate</b> Date indicator maintaining plate held by 1 screw 4000.282.
3905.070 73.		<b>Date jumper spring</b> Insert the date jumper spring in the provided opening.

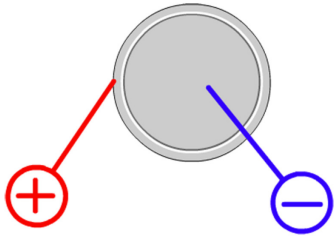
3504.215.AD.1.A 74.		<b>Tens indicator (standard)</b> Nick of the indicator at 3 o' clock.
3500.055 75.		<b>Day jumper</b>
3004.175 76.		<b>Day finger</b> Place Day finger as shown on graphic.
2130.162.G 77.		<b>Date mechanism maintaining plate</b> Date mechanism maintaining plate held by 2 screws 4000.312 and 1 screw 4000.300.

3508.155.AF.E.A 78.		<b>Day indicator (standard)</b>
2130.164.G 79.		<b>Day indicator maintaining plate</b> Day indicator maintaining plate held by 2 screws 4000.311.
4000.311 80.		<b>Screw</b>
3506.072.G 81.		<b>Dial support</b>
4000.282 82.		<b>Screw</b>
4000.300 83.		<b>Screw</b>
4000.312 84.		<b>Screw</b>

8200 85.		Moebius 8200
9014 86.		Moebius 9014
124 87.		Jismaa 124
9020 88.		Moebius 9020



Battery	<b>395</b>
Voltage	<b>1.55 V</b>

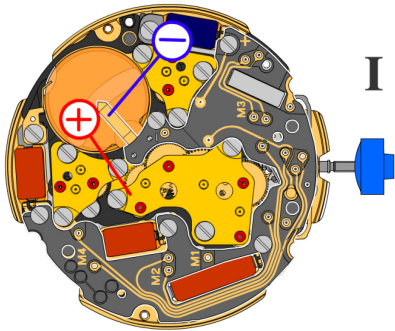

*Setting stem in position I, calendar not in gear,  
60 s measuring interval for rate and consumption:*

Typical consumption	<b>1.32 <math>\mu</math>A</b>
Maximal consumption	<b>1.65 <math>\mu</math>A</b>
Rate	<b>-10s/M. .. +20s/M.</b>
Lower working voltage limit	<b>1.20 V</b>

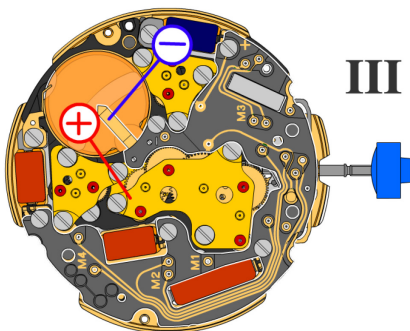

*Setting stem in position III, 60 s measuring interval:*

Typical consumption	<b>0.10 <math>\mu</math>A</b>
Maximal consumption	<b>0.30 <math>\mu</math>A</b>

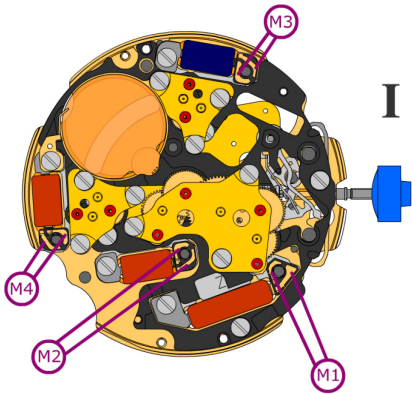

Coil resistance M1 **1.90 kΩ .. 2.10 kΩ**

Coil resistance M2 **1.68 kΩ .. 1.88 kΩ**

Coil resistance M3 **1.68 kΩ .. 1.88 kΩ**

Coil resistance M4 **1.68 kΩ .. 1.88 kΩ**

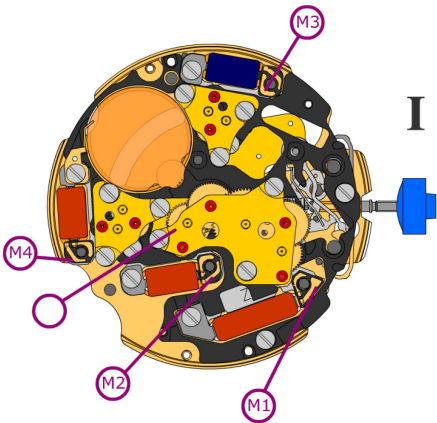

Coil isolation M1/M2/M3/M4 **∞ kΩ**

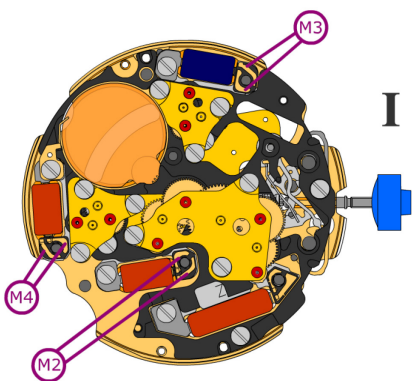

*Signal generator (4.9 ms, 8 Hz):*



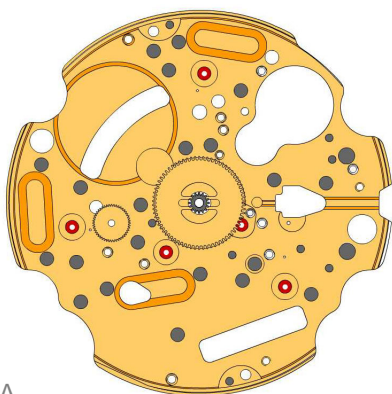



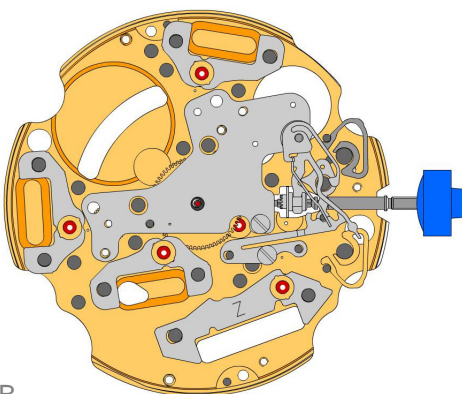











Lower working voltage limit  
M2/M3/M4 **1.20 V**









A

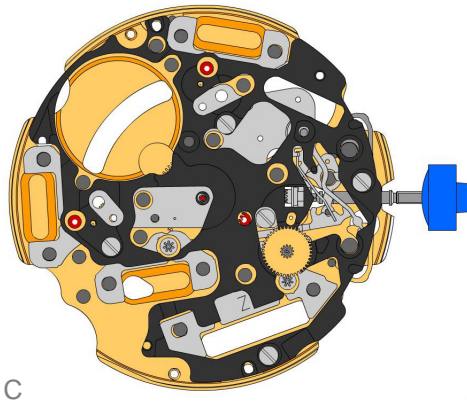





B

2000.574.G 1.		Main plate
3305.282.CO 2.		Cannon pinion with driver (Aig.2)
3301.244 3.		Hour wheel (counter 24h)
2030.032.CO 4.		Centre bridge Centre bridge held by 1 screw 4000.250. Parts 2030.017.CO, 3402.009.CO, 3004.227 and 3500.075 must be exchanged together.
4000.250 5.		Screw
3001.055.FI 6.		Sliding pinion
3000.177.CO 7.		Setting stem
3017.049 8.		Setting lever
3905.049 9.		Setting lever jumper (3 positions) Setting lever jumper held by 1 screw 4000.250.
3015.081 10.		Yoke (3 positions) Parts 3015.081 and 3905.067 must be exchanged together.
3905.067 11.		Yoke spring Tensioning the spring arm. Parts 3015.081 and 3905.067 must be exchanged together.
3406.030 12.		Pusher jumper B Put the grey jumper between the two posts on the further side.
3406.038 13.		Pusher jumper A Put the yellow jumper between the two posts on the closer side.
3622.040 14.		Stator Mark [Z] on stator.
3622.039 15.		Stator (counter 6h, 9h, chrono)
3622.039 16.		Stator (counter 6h, 9h, chrono)
3622.039 17.		Stator (counter 6h, 9h, chrono)
4000.250 18.		Screw

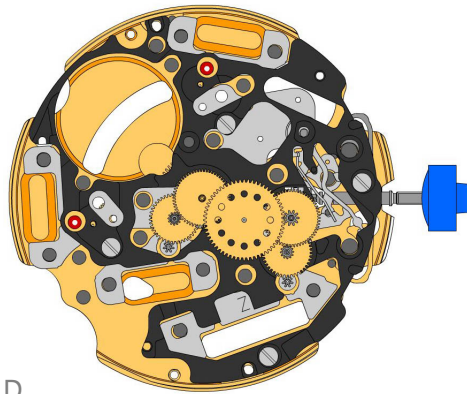



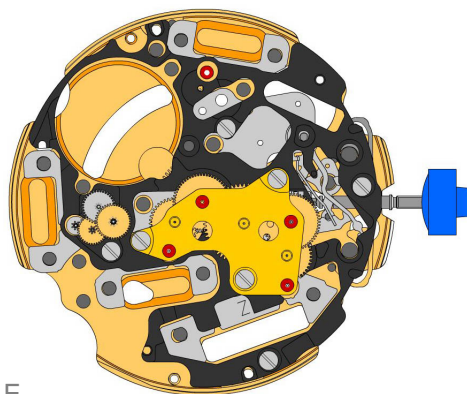

**C**

3603.079 19.		<b>Plastic bracket</b> Plastic bracket held by 4 screws 4000.250.
4000.250 20.		<b>Screw</b>
3715.094.RK 21.		<b>Rotor</b>
3715.094.RK 22.		<b>Rotor</b>
3147.046.CO 23.		<b>Intermediate wheel</b>





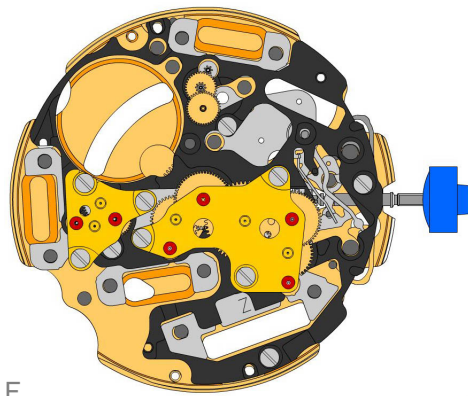

**D**

3136.142.CO 24.		<b>Second wheel (long)</b>
3147.047.CO 25.		<b>Intermediate wheel (chrono)</b>
3136.144.CO 26.		<b>Chronograph wheel (Aig.2)</b>
3122.056.CO 27.		<b>Third wheel</b>









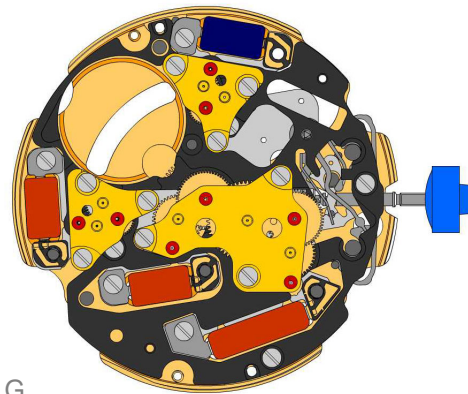

**E**

2020.148.G 28.		<b>Train wheel bridge</b> Train wheel bridge held by 3 screws 4000.250.
4000.250 29.		<b>Screw</b>
3715.095.RK 30.		<b>Rotor</b>
3147.048.CO 31.		<b>Intermediate wheel (counter)</b>
3007.056.CO 32.		<b>Minute wheel (counter 24h)</b>
3402.008.CO 33.		<b>Minute counting wheel</b>





**F**

2020.149.G 34.		<b>Counter train wheel bridge</b> Counter train wheel bridge held by 3 screws 4000.250.
4000.250 35.		<b>Screw</b>
3715.095.RK 36.		<b>Rotor</b>
3147.053.CO 37.		<b>Intermediate wheel (counter 1/10sec)</b>
3402.009.CO 38.		<b>Counting wheel 1/10 sec</b> Parts 2030.017.CO, 3402.009.CO, 3004.227 and 3500.075 must be exchanged together.

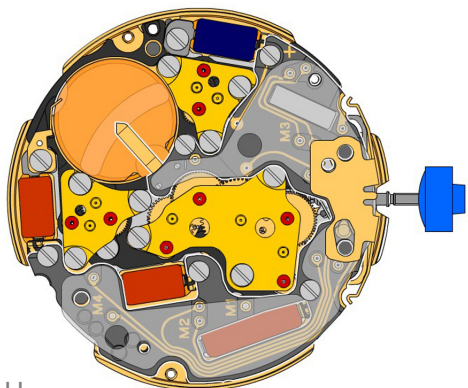
**G**

2020.149.G 39.		<b>Counter train wheel bridge</b> Counter train wheel bridge held by 3 screws 4000.250.
4000.250 40.		<b>Screw</b>
3621.053.RK 41.		<b>Coil</b> Attention: Please hold the coil only on the grey coil core. Coil held by 1 screw 4000.250.
3621.054.RK 42.		<b>Coil (counter 9h, chrono)</b> Attention: Please hold the coil only on the grey coil core. Coil held by 1 screw 4000.250.
3621.054.RK 43.		<b>Coil (counter 9h, chrono)</b> Attention: Please hold the coil only on the grey coil core. Coil held by 1 screw 4000.250.
3621.055.RK 44.		<b>Coil (counter 6h)</b> Attention: Please hold the coil only on the grey coil core. Coil held by 1 screw 4000.250.
4000.250 45.		<b>Screw</b>
3601.118 46.		<b>Contact strip</b> Contact strip held by 1 screw 4000.250.
3603.034 47.		<b>Battery insulator</b>

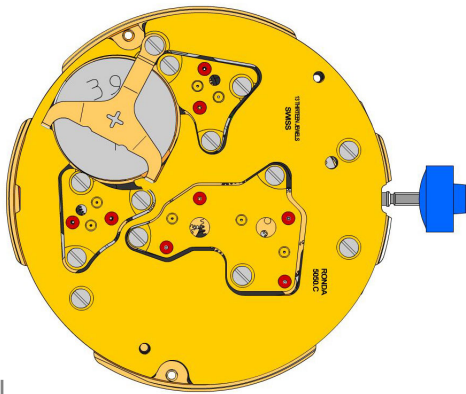

**H**

3612.144.5050 48.		<b>Electronic module</b> Electronic module held by 5 screws 4000.248. Electronic measurements may be realised now.
4000.248 49.		<b>Screw</b>
3603.069 50.		<b>Circuit insulator</b>
3601.107.G 51.		<b>Pusher contact spring</b>











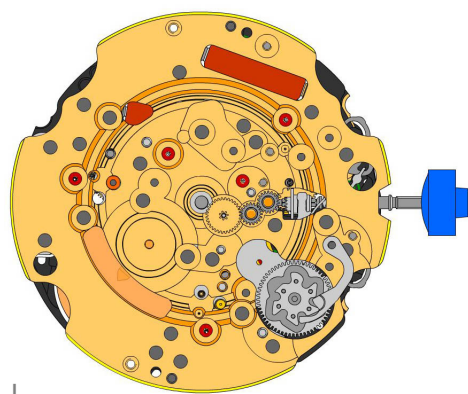
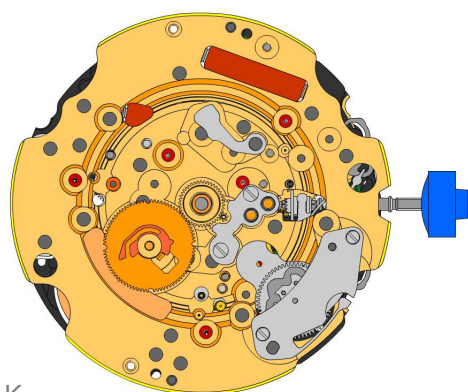





2130.137.G.M01.5050C  
52.  **Electronic module cover**  
Electronic module cover held by 3 screws 4000.250.

3600.010.HGF  
53.  **Battery 395**





3601.109.G  
54.  **Bridge +**  
Bridge held by 1 screw 4000.250.



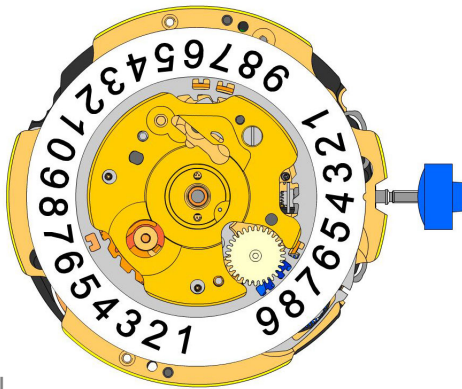
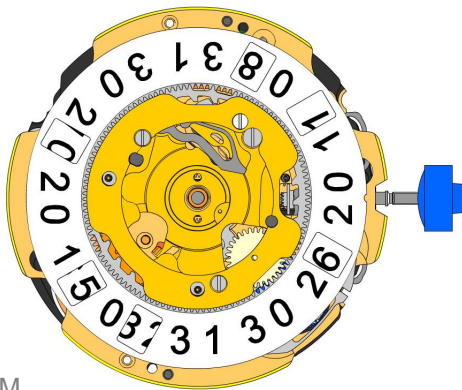
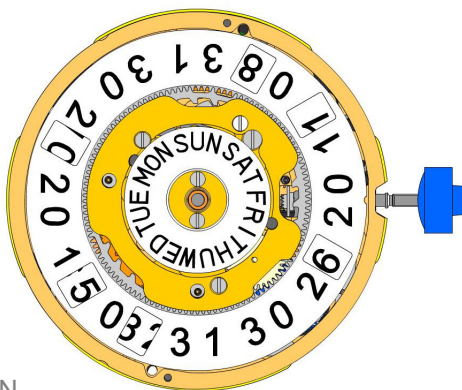

4000.250  
55.  **Screw**









**J**

**K**





2000.574.G 56.		Main plate
3004.164 57.		Setting wheel
3004.164 58.		Setting wheel
3007.054.CO 59.		Minute wheel
2130.143 60.		Minute train bridge Minute train bridge held by 2 screws 4000.305.
4000.305 61.		Screw
3004.227 62.		Tens indicator driving wheel Parts 2030.017.CO, 3402.009.CO, 3004.227 and 3500.075 must be exchanged together. The short tooth of the tens indicator driving wheel must point to the center of the movement.
3500.075 63.		Tens jumper Parts 2030.017.CO, 3402.009.CO, 3004.227 and 3500.075 must be exchanged together.
2130.142 64.		Tens jumper maintaining plate Tensioning the spring arm. Tens jumper maintaining plate held by 2 screws 4000.306.
4010.306 65.		Screw
3301.242 66.		Hour wheel (Fig.2)
3315.016 67.		Friction spring
3004.224.CO 68.		Date indicator driving wheel
3500.049 69.		Date jumper



**L**

**M**

**N**

3504.214.AD.1.A 70.		<b>Units indicator (standard)</b> Nick of the indicator at 3 o'clock.
3147.054 71.		<b>Tens intermediate wheel</b>
2130.163 72.		<b>Date indicator maintaining plate</b> Date indicator maintaining plate held by 1 screw 4000.282.
3905.070 73.		<b>Date jumper spring</b> Insert the date jumper spring in the provided opening.

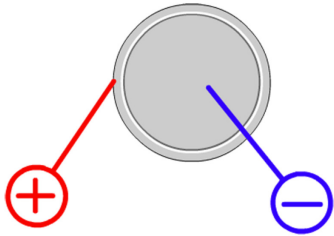
3504.215.AD.1.A 74.		<b>Tens indicator (standard)</b> Nick of the indicator at 3 o'clock.
3500.055 75.		<b>Day jumper</b> Tensioning the spring arm.
3004.175 76.		<b>Day finger</b> Place Day finger as shown on graphic.
2130.162.G 77.		<b>Date mechanism maintaining plate</b> Date mechanism maintaining plate held by 2 screws 4000.312 and 1 screw 4000.300.

3508.155.AF.E.A 78.		<b>Day indicator (standard)</b>
2130.164.G 79.		<b>Day indicator maintaining plate</b> Day indicator maintaining plate held by 2 screws 4000.311.
4000.311 80.		<b>Screw</b>
3506.072.G 81.		<b>Dial support</b>
4000.282 82.		<b>Screw</b>
4000.300 83.		<b>Screw</b>
4000.312 84.		<b>Screw</b>

8200 85.		Moebius 8200
9014 86.		Moebius 9014
124 87.		Jismaa 124
9020 88.		Moebius 9020



Battery	<b>395</b>
Voltage	<b>1.55 V</b>

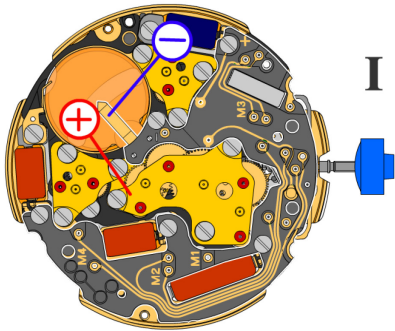

*Setting stem in position I, calendar not in gear,  
60 s measuring interval for rate and consumption:*

Typical consumption	<b>1.32 <math>\mu</math>A</b>
Maximal consumption	<b>1.65 <math>\mu</math>A</b>
Rate	<b>-10s/M. .. +20s/M.</b>
Lower working voltage limit	<b>1.20 V</b>

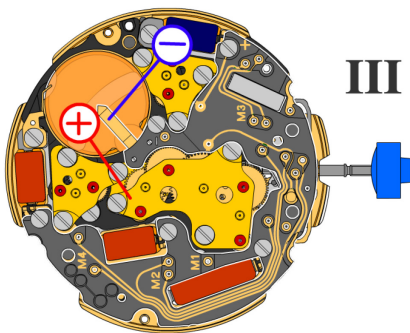

*Setting stem in position III, 60 s measuring interval:*

Typical consumption	<b>0.10 <math>\mu</math>A</b>
Maximal consumption	<b>0.30 <math>\mu</math>A</b>

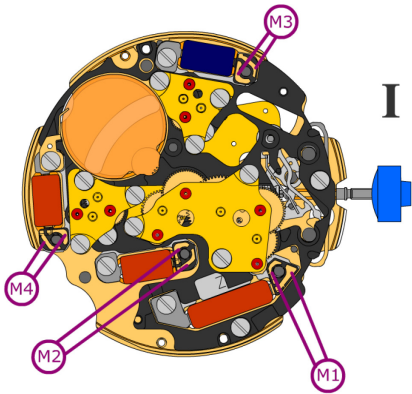

Coil resistance M1 **1.90 k $\Omega$  .. 2.10 k $\Omega$**

Coil resistance M2 **1.68 k $\Omega$  .. 1.88 k $\Omega$**

Coil resistance M3 **1.68 k $\Omega$  .. 1.88 k $\Omega$**

Coil resistance M4 **1.68 k $\Omega$  .. 1.88 k $\Omega$**

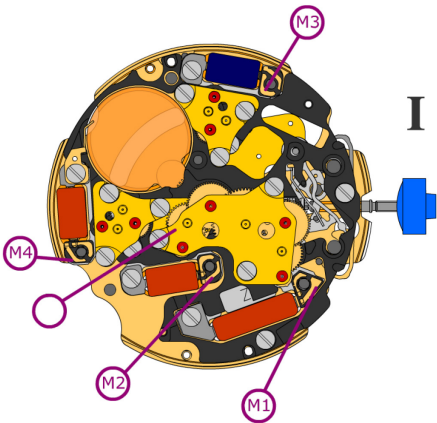

Coil isolation M1/M2/M3/M4  **$\infty$  k $\Omega$**

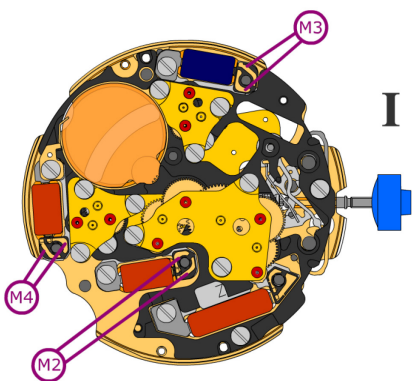

*Signal generator (4.9 ms, 8 Hz):*

Lower working voltage limit M2/M3/M4 **1.20 V**