

Cal. VD73A

ϕ 23.70 mm

H 3.45 mm

Item	Version No.
Specification - 1	Version 3
Specification - 2	Version 1
Appearance	Version 3
Casing	Version 6
Hand Fitting	Version 3
Hand Setting Stem	Version 4
Dial	Version 2
Casing Ring	Version 1
Assembly Plan	Version 4
Hands	Version 2



MOVEMENT SPECIFICATION - 1

CAL.VD73A 10 1/2 Ligne Quartz Movement Two Hands with Two Eyes (Date/Small second)

1. MOVEMENT DIMENSIONS

- Outside diameter $\phi 23.70$ 22.60mm (12H~6H) x 22.60mm (3H~9H)
- Casing diameter $\phi 23.30$ 22.10mm (12H~6H) x 21.40mm (3H~9H)
- Total height 3.45 mm

2. TIME STANDARD

- Type of quartz oscillator Tuning fork
- Frequency of quartz oscillator 32,768 H Z
- Accuracy Monthly rate: Less than 20 seconds per month at normal temperature range
- Regulation device Nil
- Regulation hands unbalance Minute : Less than 0.6 μ N·m (60mg·mm)
Hour : Less than 0.6 μ N·m (60mg·mm)
- Small hands unbalance Less than 0.05 μ N·m (5mg·mm)
for date & small second hands

3. BATTERY

- Type Silver oxide battery
- Size $\phi 6.8$ x t 2.6 (mm)
- Nominal voltage 1.55V
- Battery life Approx. 3 years
- Recommended battery SR626SW (SEIZAIKEN)

4. STEPPING MOTOR

- Type Two pole stepping motor
- Step 180° every second

5. JEWEL

0 jewel

6. ANTIMAGNETISM

(direct current magnetic field)

≥ 1600 A / m

7. SHOCK RESISTANCE

On equal level with general quartz movement

8. OPERATING TEMPERATURE RANGE

From - 5°C to + 50°C

9. TEST OF ACCURACY

- Equipment to be used SEIKO Quartz Tester QT - 99
Greiner Quartz Timer - C
Watch Q-Tester 4000
- Duration of measurement 10 seconds
- Microphone to be used Electromagnetic detection type

*** All specifications are subject to change without notice.**

Movement Specification - 2

CAL. VD73A

OPERATION

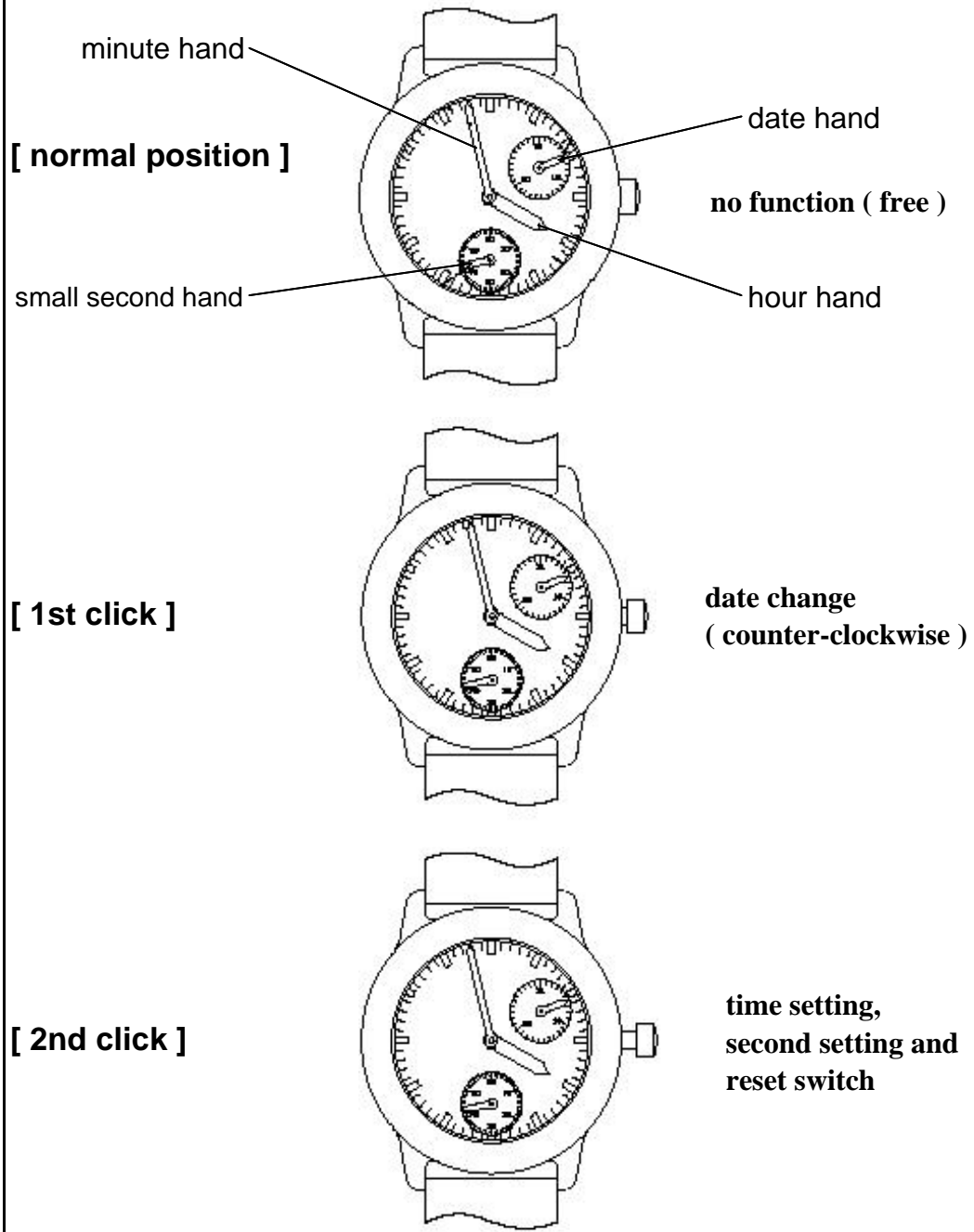

Version 1

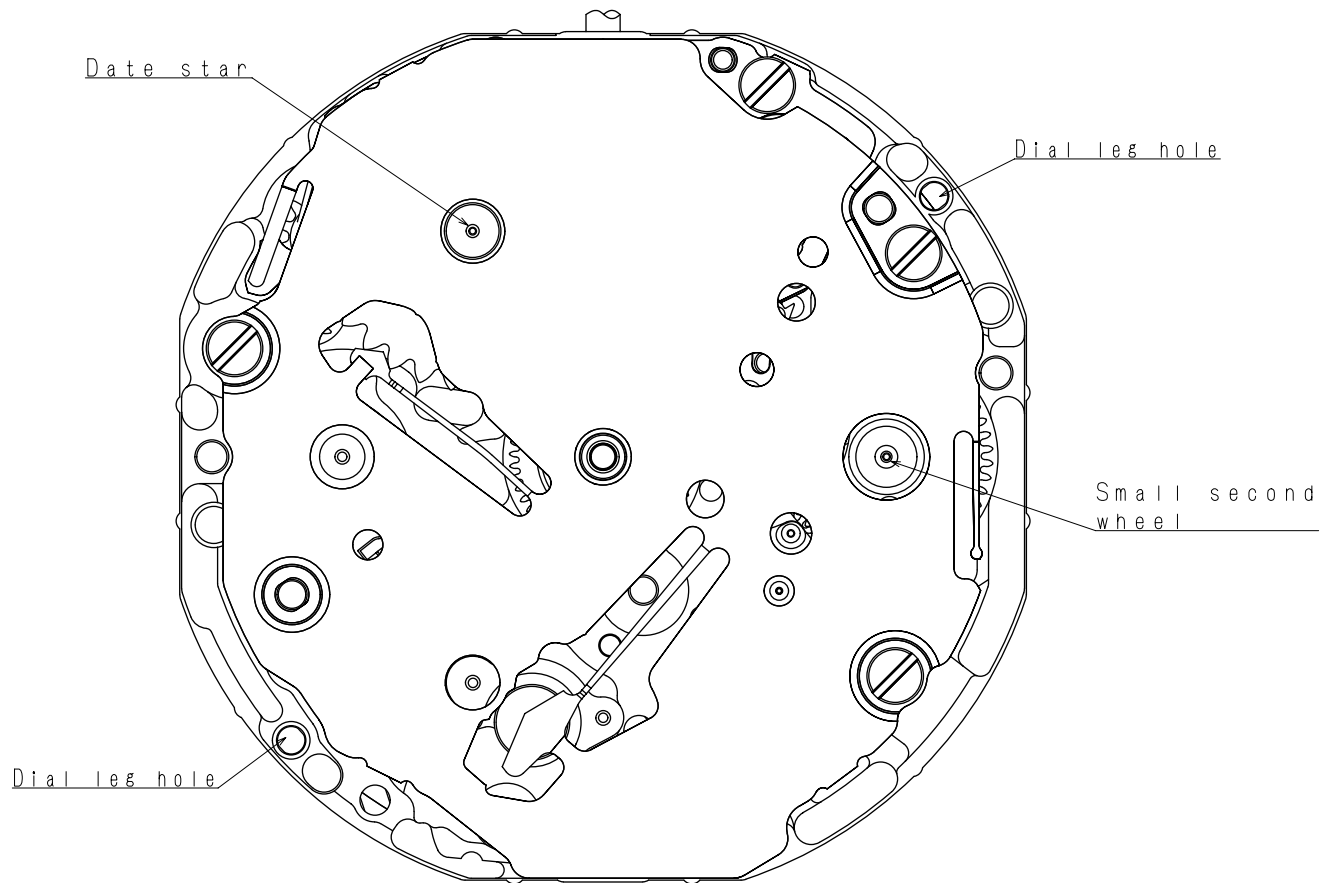
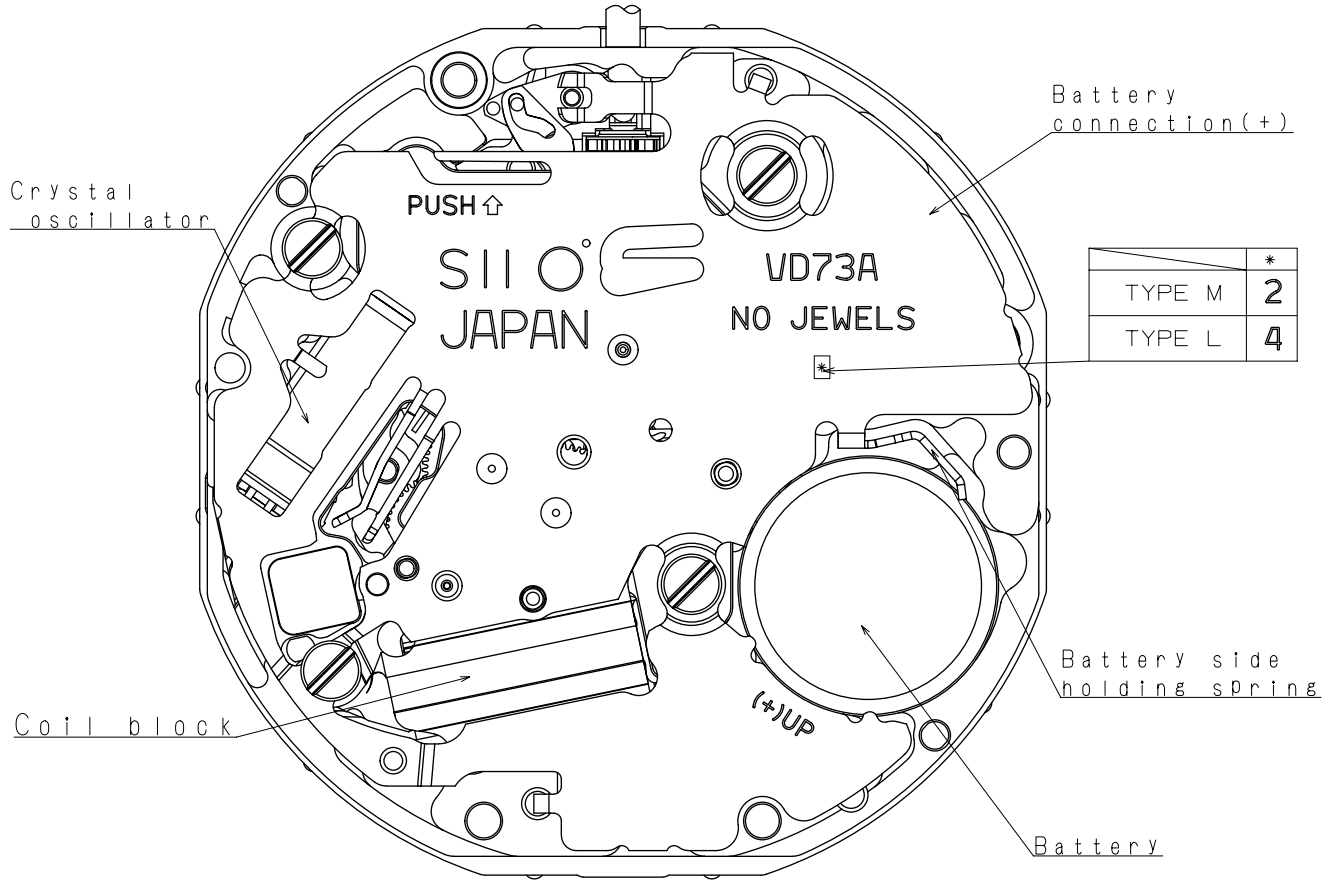

Scale : 5/1
Unit : 1=1/100mm

Version:3

* First pull out stroke 45
** Second pull out stroke 39.9

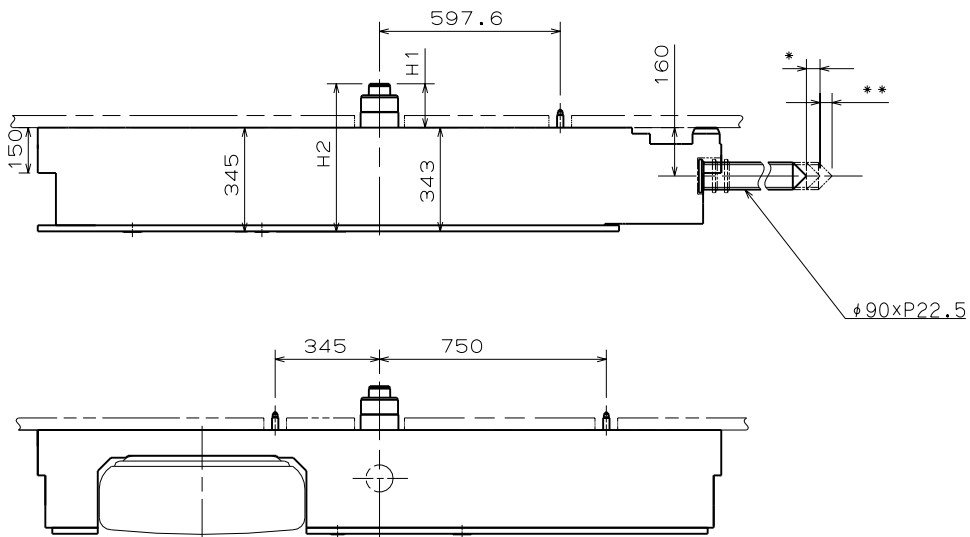

Center Post		TYPE M	TYPE L
Maximum height from main plate surface	H1	150	230
Total height incl. movement	H2	495	575

Hand Setting Stem	TYPE A	TYPE B
L1	2436	3012

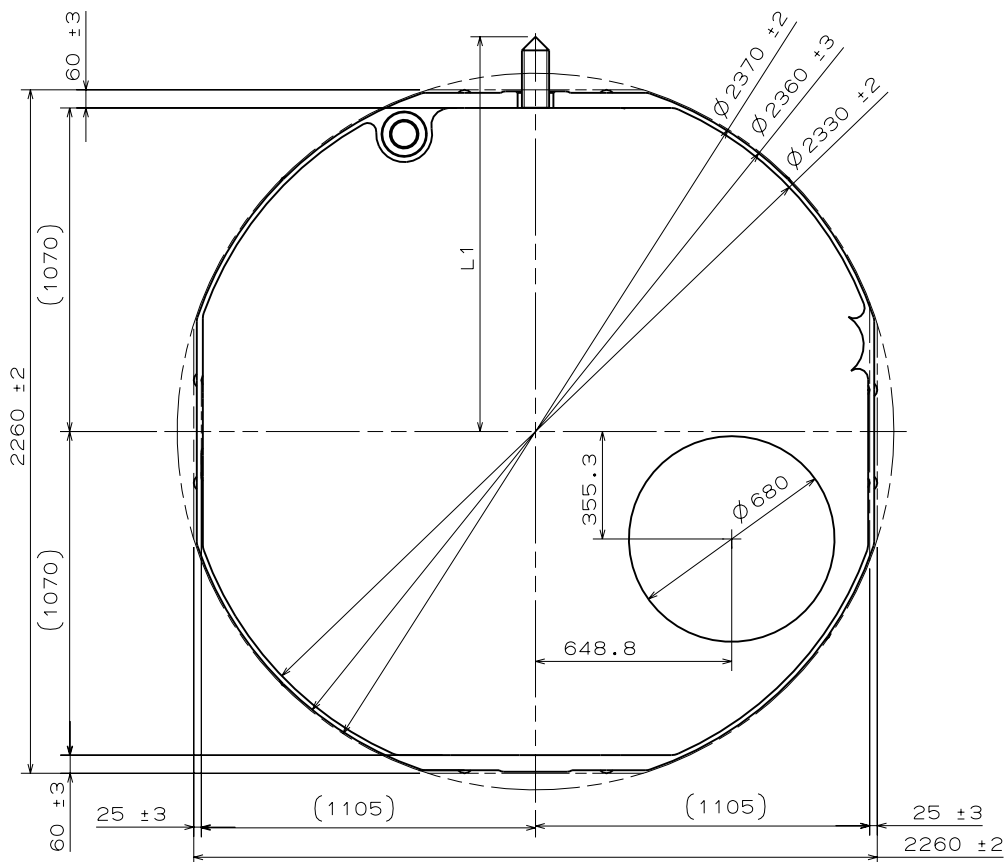

Scale : 4/1

Unit : 1=1/100mm

Version:6

Hand Fitting

Cal. VD73A

- *Hour hand unbalance $\leq 0.6 \mu\text{N}\cdot\text{m}$ (60mg·mm)
- *Minute hand unbalance $\leq 0.6 \mu\text{N}\cdot\text{m}$ (60mg·mm)
- *Small second hand unbalance $\leq 0.05 \mu\text{N}\cdot\text{m}$ (5mg·mm)
- *Date hand unbalance $\leq 0.05 \mu\text{N}\cdot\text{m}$ (5mg·mm)

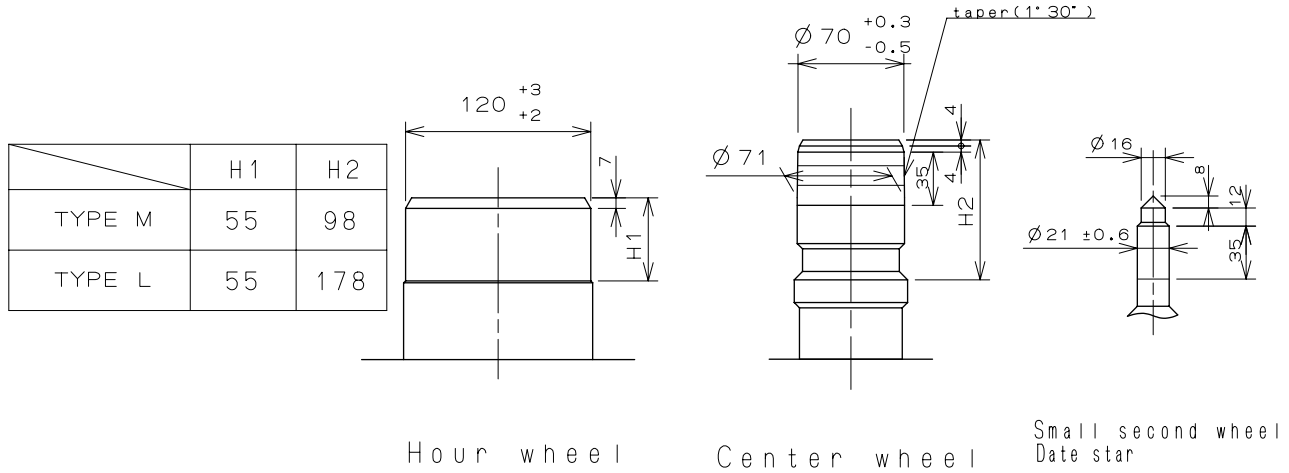

Part name	Part No.	
	TYPE M	TYPE L
Hour wheel	0273 1690	0273 0350
Center wheel	0221 0690	0221 0760
Small second wheel	0240 1690	0240 0150
Date star	0970 1690	0970 0370

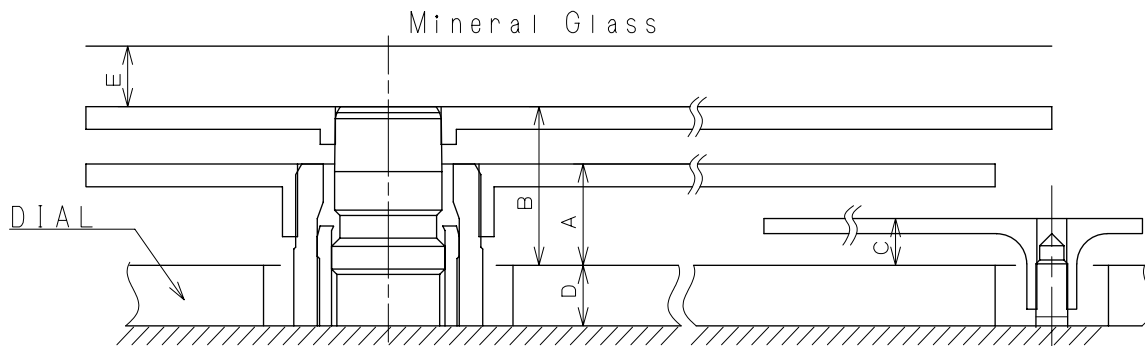

	A	B	C	D	E
TYPE M	72	110	31	40	35
TYPE L	95	145	41	85	40

Scale : 20/1

Unit : 1=1/100mm

Version : 3

- *Hour hand unbalance $\leq 0.6\mu\text{N}\cdot\text{m}$ (60mg·mm)
- *Minute hand unbalance $\leq 0.6\mu\text{N}\cdot\text{m}$ (60mg·mm)
- *Small second hand unbalance $\leq 0.05\mu\text{N}\cdot\text{m}$ (5mg·mm)
- *Date hand unbalance $\leq 0.05\mu\text{N}\cdot\text{m}$ (5mg·mm)

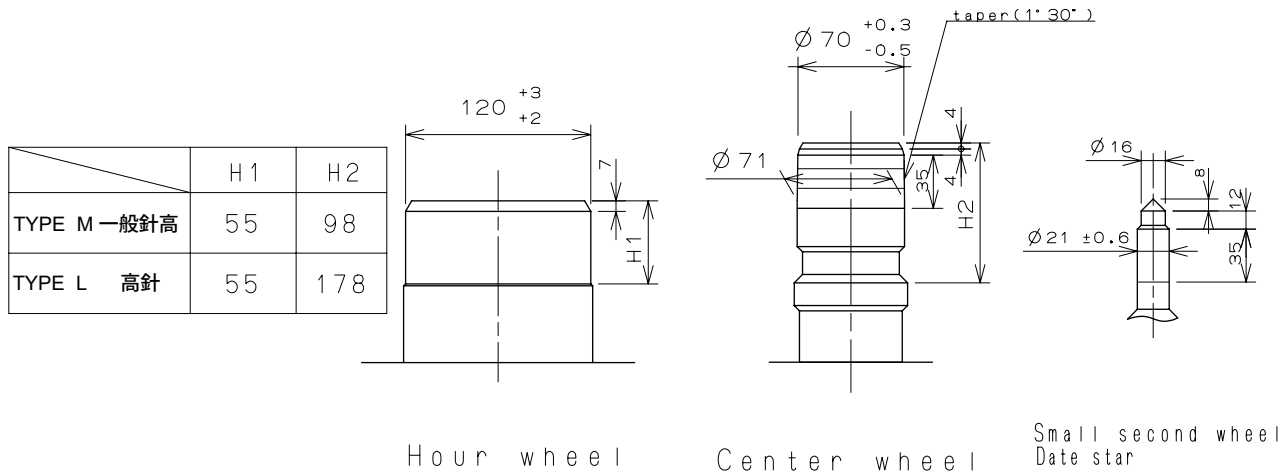

Part name	Part No.	
	TYPE M 一般針高	TYPE L 高針
Hour wheel 時針輪	0273 1690	0273 0350
Center wheel 分針輪	0221 0690	0221 0760
Small second wheel 小秒針輪	0240 1690	0240 0150
Date star 日曆針輪	0970 1690	0970 0370

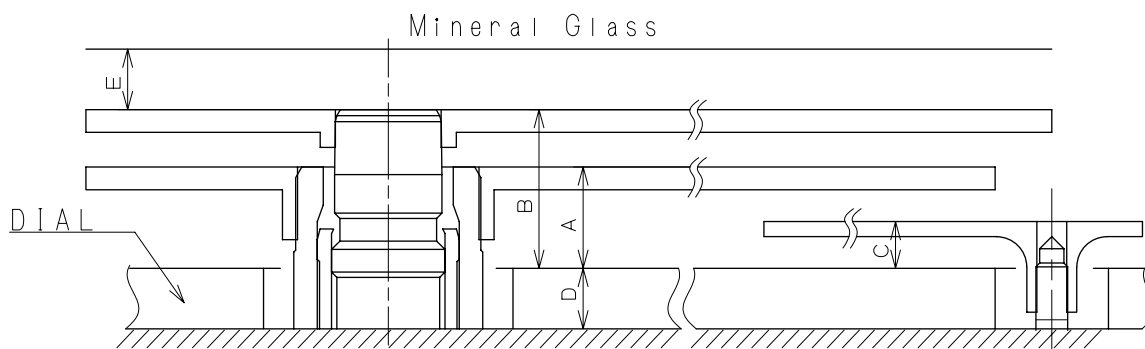

	A	B	C	D	E
TYPE M 一般針高	72	110	31	40	35
TYPE L 高針	95	145	41	85	40

Scale : 20/1

Unit : 1=1/100mm

Version : 3

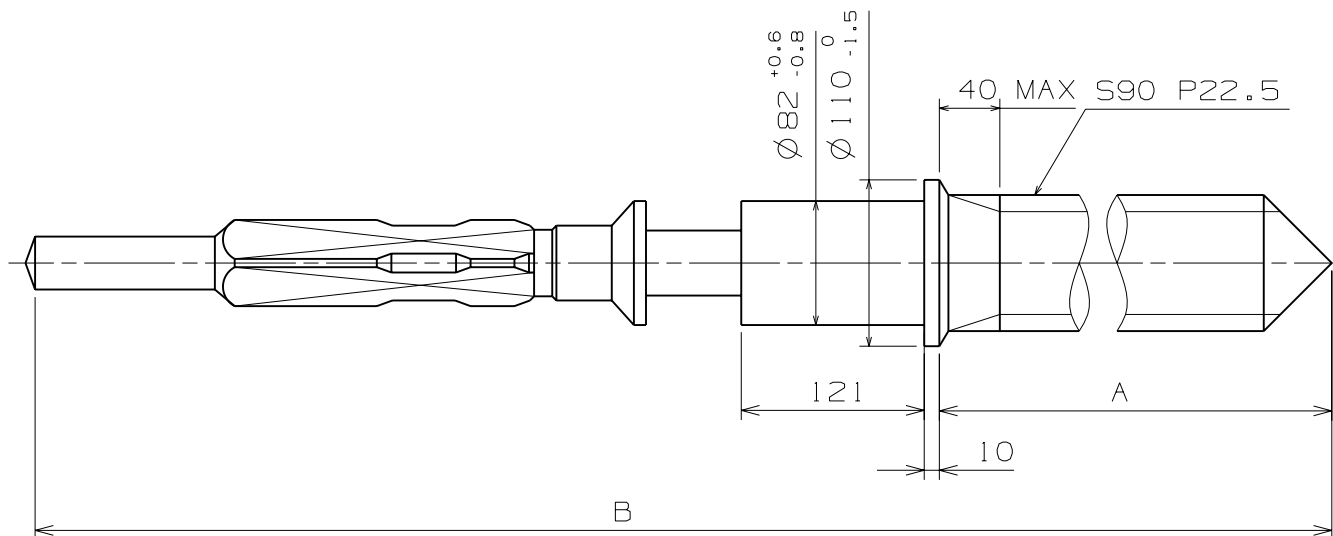

	Part. No.	A	B
TYPE A	0351 1770	1371	1969
TYPE B	0351 1220	1947	2545

Scale : 20/1

Unit : 1=1/100mm

Version:4

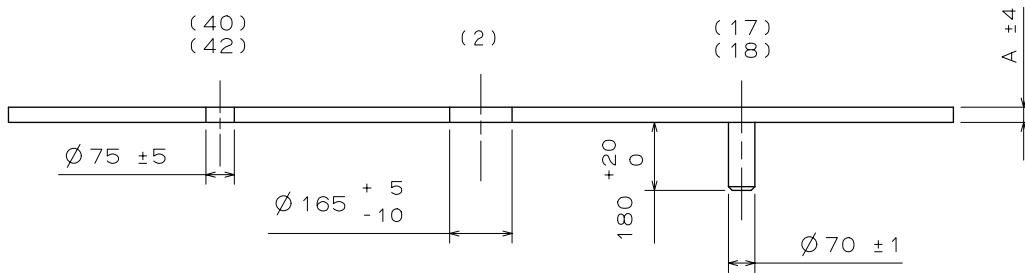
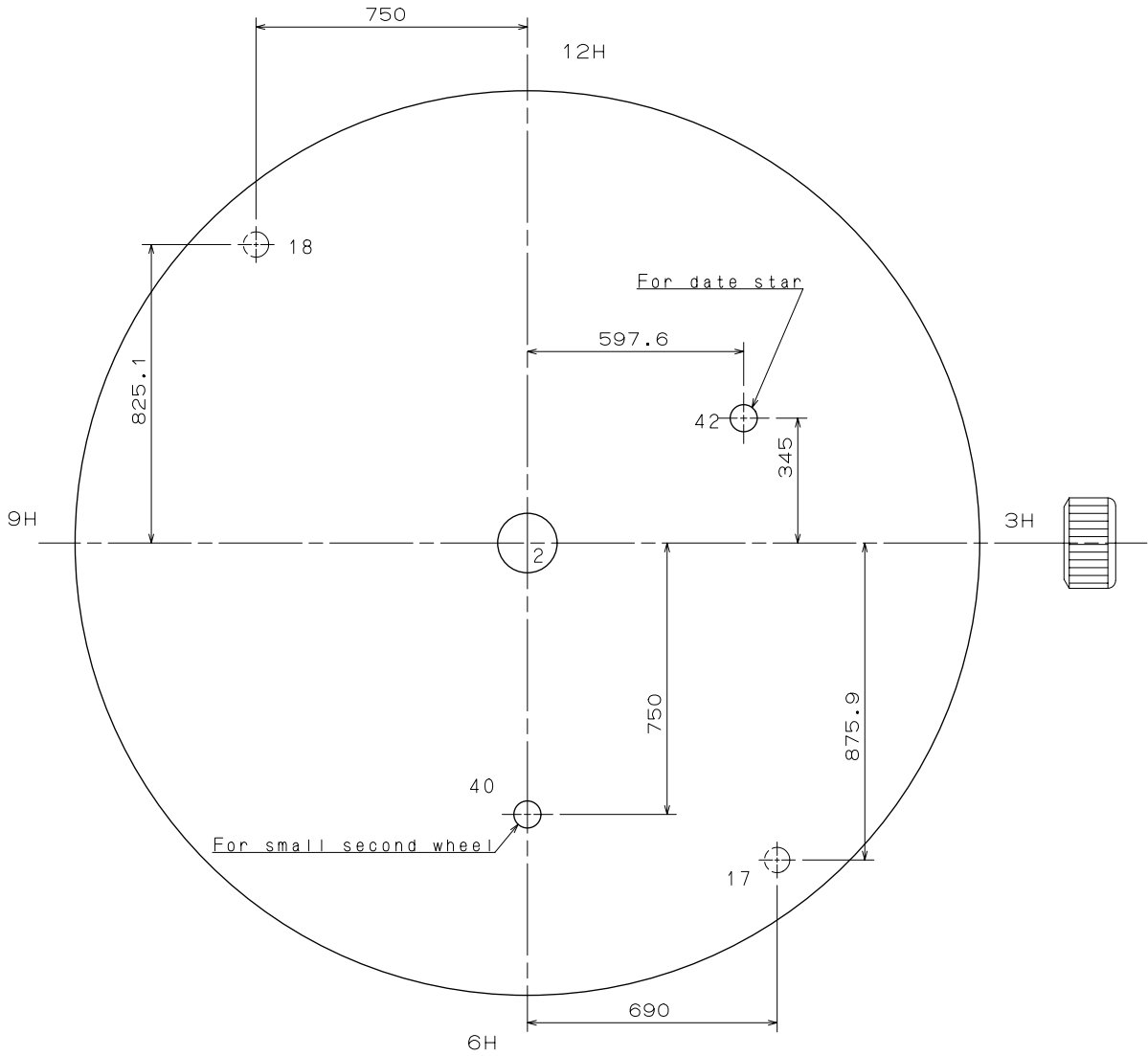

	TYPE M	TYPE L
A	40	85

Scale : 5/1
Unit : 1=1/100mm

Version:2

Casing Ring

Cal. VD73A

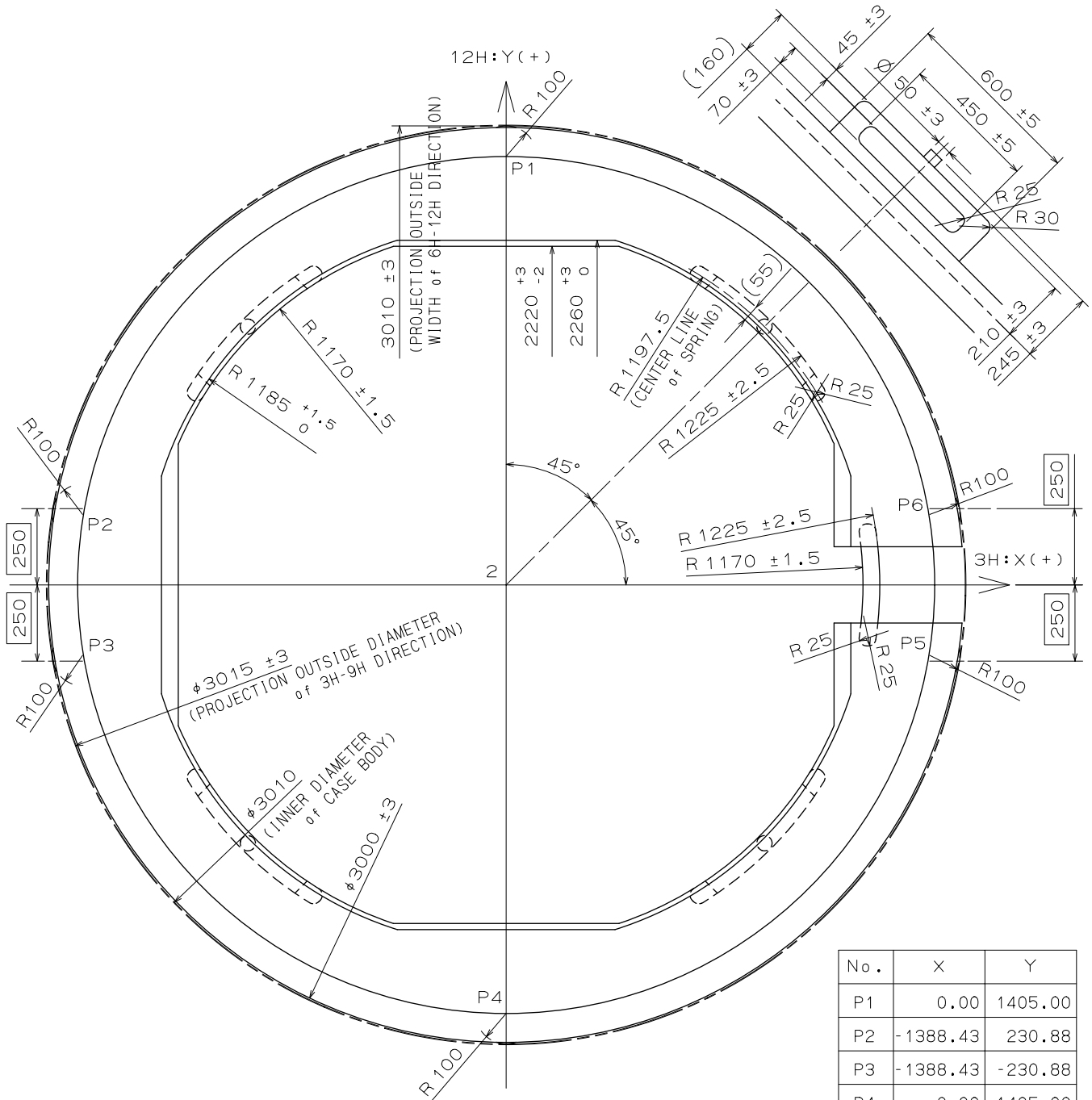

No.	X	Y
P1	0.00	1405.00
P2	-1388.43	230.88
P3	-1388.43	-230.88
P4	0.00	-1405.00
P5	1388.43	-230.88
P6	1388.43	230.88

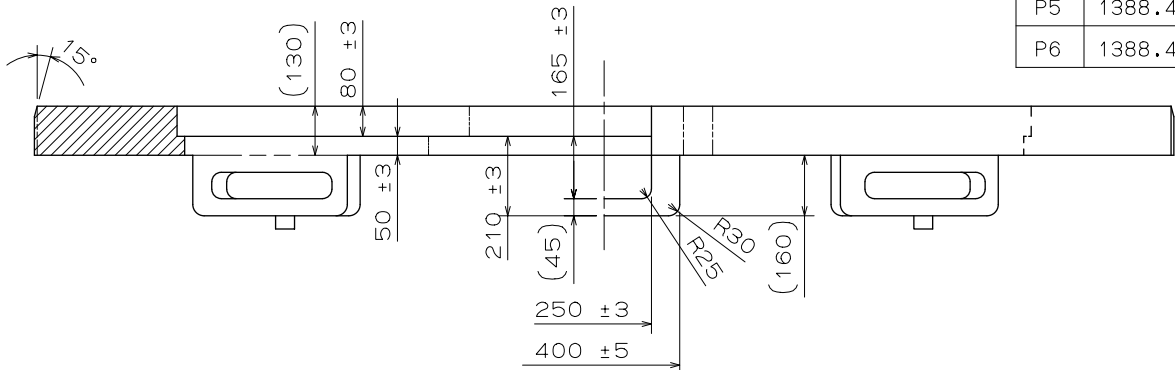

SECTIONAL VIEW of 6H(12H) DIRECTION

SIDE VIEW of 3H DIRECTION

Scale : 5/1
Unit : 1=1/100mm

Version:1

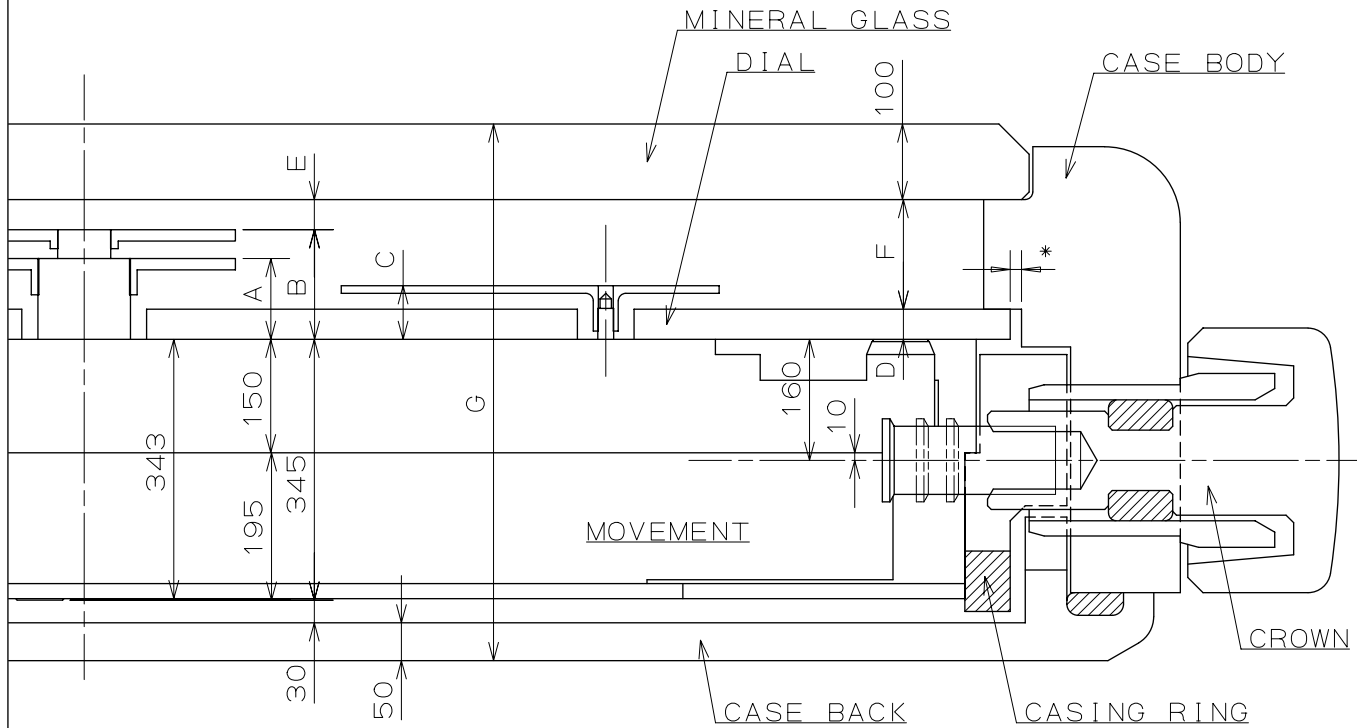

	A	B	C	D	E	F	G
TYPE M	112	150	71	40	35	145	710
TYPE L	180	230	126	85	40	185	795

*Recommended Dimension(Clearance of DIAL and CASE BODY):15

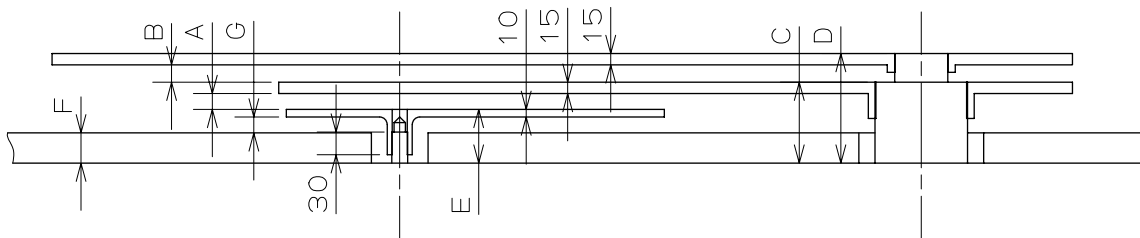

	A	B	C	D	E	F	G
TYPE M	26	23	112	150	71	40	21
TYPE L	39	35	180	230	126	85	31

Scale : 10/1

Unit : 1=1/100mm

Version:4

TYPE M

MINUTE

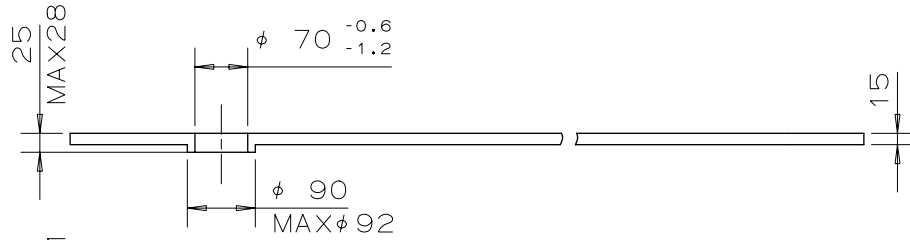

HOUR

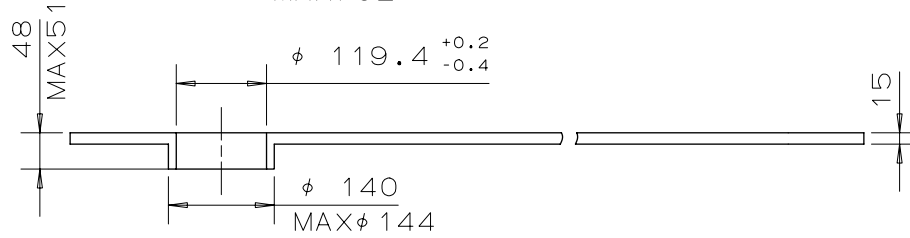

SMALL SECOND
DATE

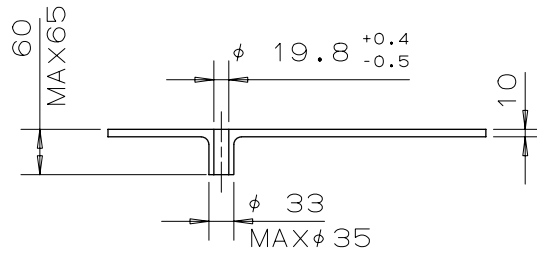

TYPE L

MINUTE

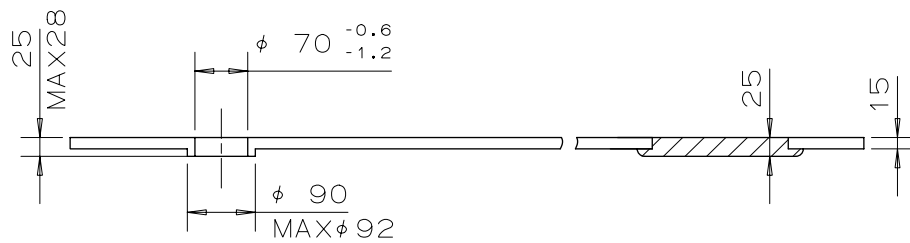

HOUR

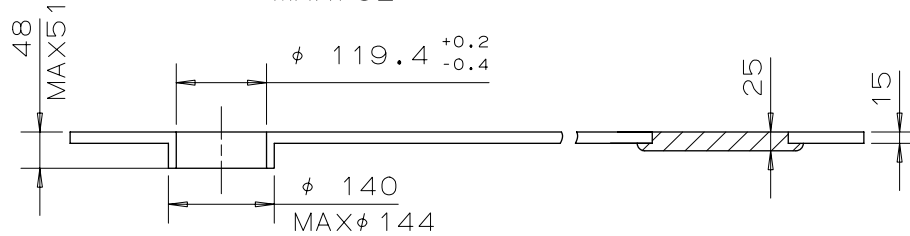

SMALL SECOND
DATE

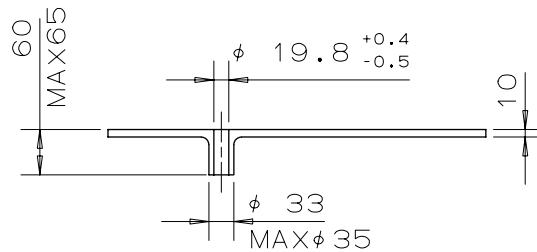

Scale : 10/1

Unit : 1=1/100mm

Version:2