

RONDA powertech 500 and 762E, 763E

Affordable metal movements
for reliable quality watches

Caliber 515.24D – 11½'''

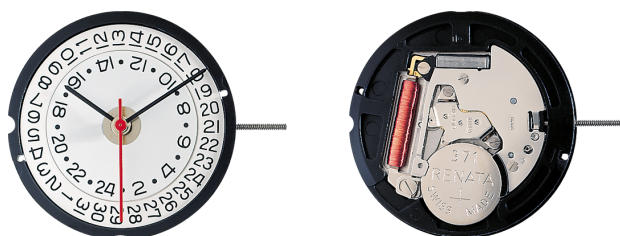

Product Specifications

Analog quartz movement

Line powertech

Caliber 515.24D

Size 11½'''

Version Swiss Made 1 Jewels / nickel plated
Swiss Parts 1 Jewels / nickel plated

Standard battery life 45 months

Hand fitting height 1

Features

- Repairable metal watch movement
- Power saving mechanism with pulled out stem: Reduction of consumption approximately 70%
- Interchangeability: All versions 11½''' with same movement height 3.00 mm and stem height 1.50 mm
- Very powerful stepping motor
- GMT function with quick change

Functions

- Date
- 24 hours by disc – GMT function
- 24 hours
- 3 hands

Technical Specifications

Diameter Total	26.00 mm
Case fitting	25.60 mm
Movement height	3.00 mm
Height over standard battery	3.25 mm
Movement rest	0.80 mm
Height over stem	1.50 mm
Length of stem travel	1.00 mm
Force to push the stem for screwed crown	N
Stem thread	0.90 mm
Standard battery	371
Standard battery life	45 months
Battery voltage	1.5 V
Current consumption – typical	1.28 µA (Date Mechanism not in Gear)
Current consumption – maximum	1.85 µA (Date Mechanism not in Gear)
Useful torque second – typical	11 µNm
Useful torque minute – typical	550 µNm
Operating temperature	0 - 50 °C
Instantaneous rate	-10/ +20 sec/month
Resistance to magnetic fields	18.8 Oe
Resistance against shock	NIHS 91-10



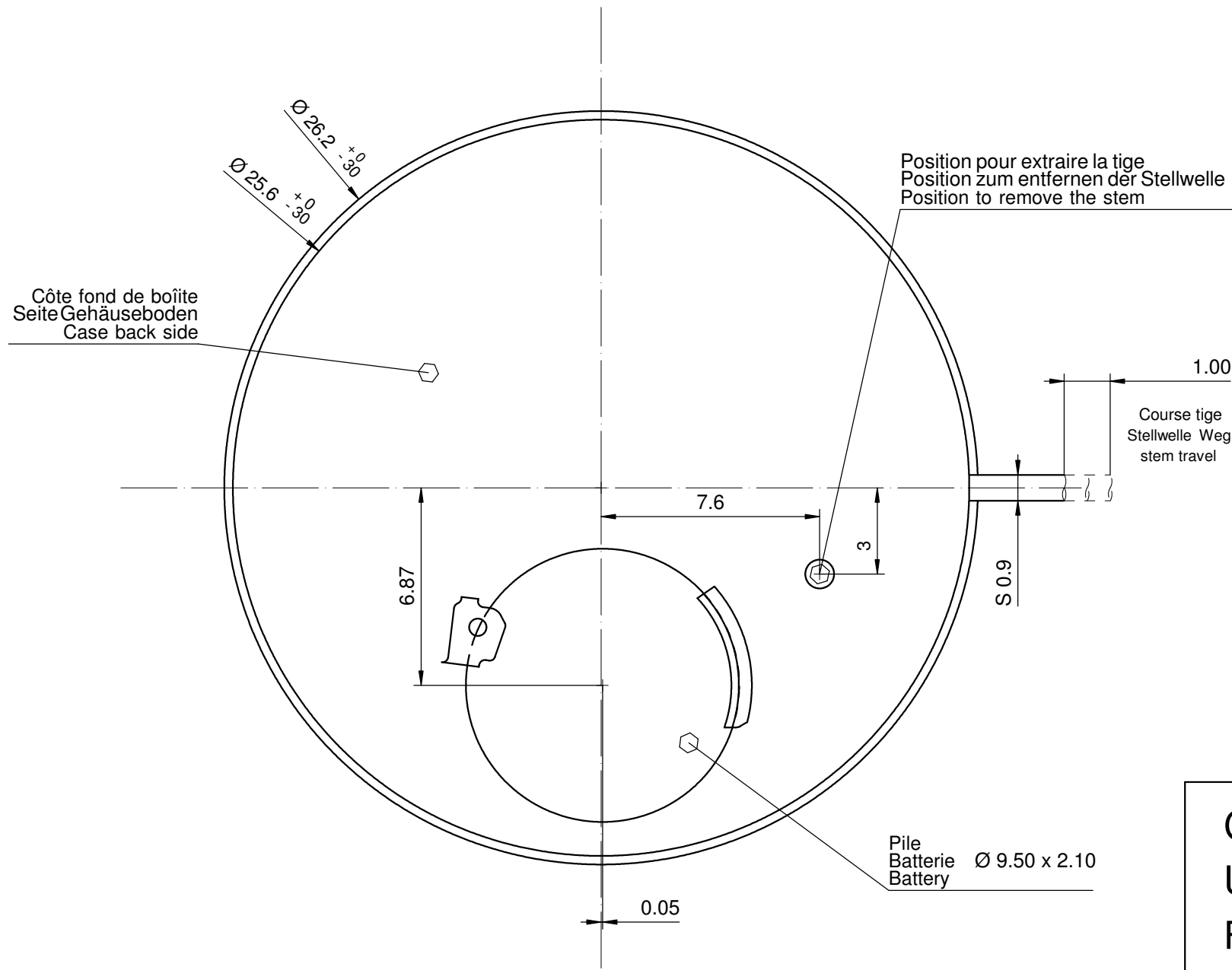
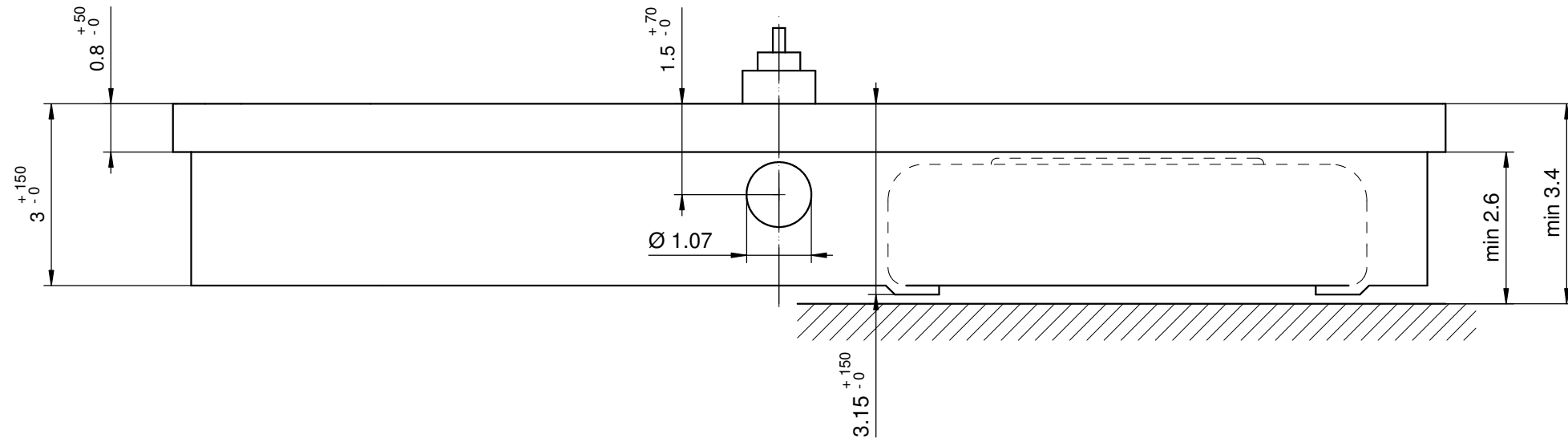

Sécurité entre aiguille seconde et verre : min 0.30 mm
 Sicherheit zwischen Sekundenzeiger und Glas : min 0.30 mm
 Security between second hand and glass : min 0.30 mm

Le cadran doit être maintenu en hauteur par la boîte.
 Das Zifferblatt muss in der Höhe vom Gehäuse festgehalten werden.
 The dial must be held in the height by the case.

Cage Uhrwerkgestell Frame		1 1/2"		Issued	10 Mrz 1999	gd
				Modified	23 Jun 2011	dh
				Released	ÄÄ 11169	
				Tolerance	+/- 20 µm	
				Scale	10 : 1 (5 : 1) (A3H)	
RONDA	515.24D	Sous réserve de modifications Änderungen vorbehalten Modifications reserved				
		No.	5000.297	05		

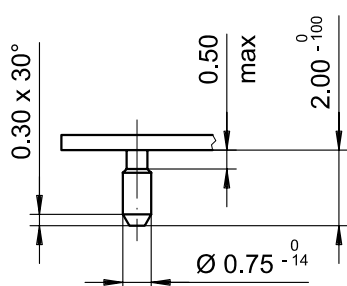
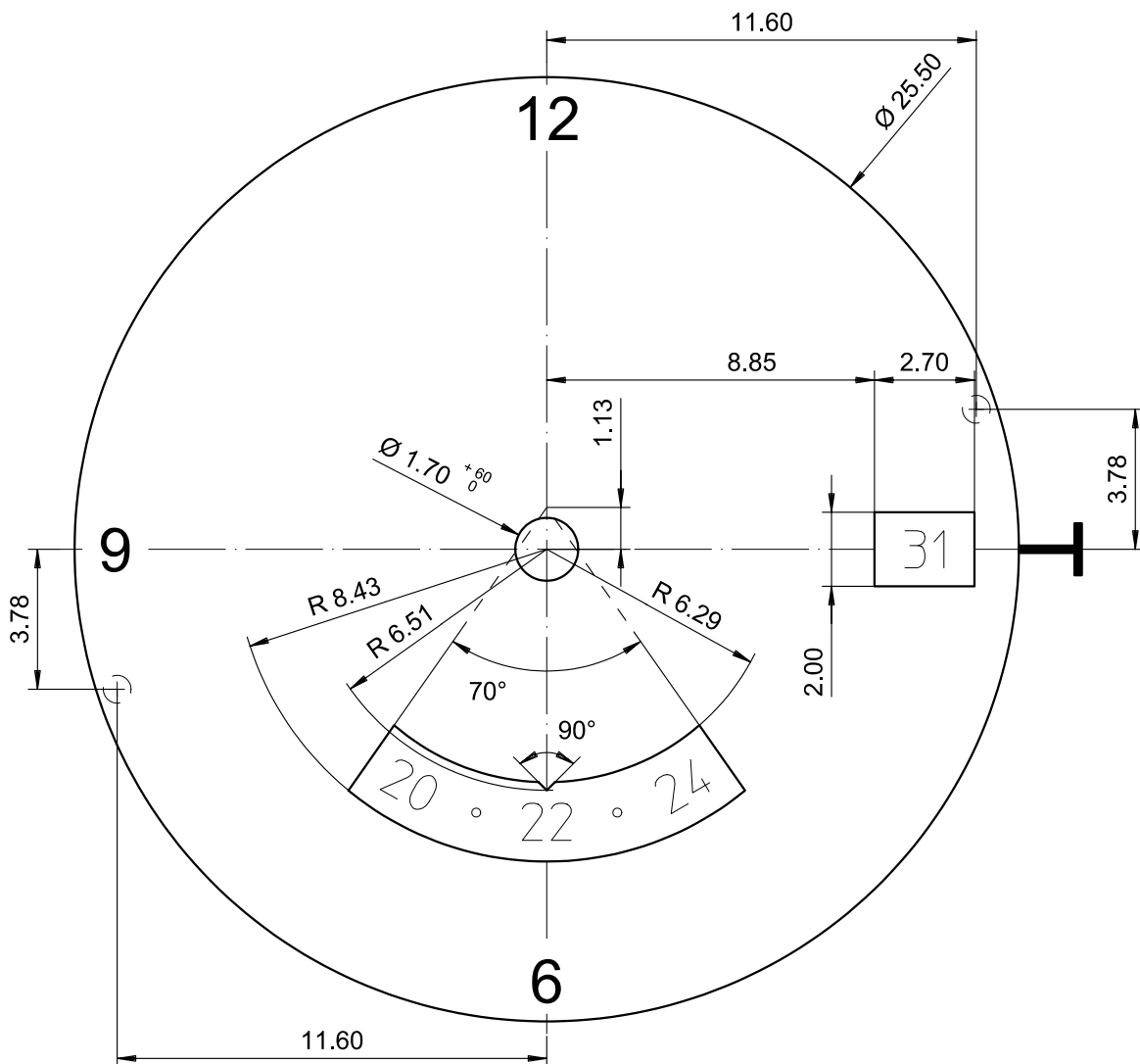

Epaisseur du cadran selon hauteur de l'aiguillage
 Zifferblattdicke gemäss Zeigerwerkhöhen
 Dial thickness according to hand fitting heights

Tige	Date	24h
Stellw.	Datum	24h
Stem	Date	24h
3H	3H	6H

Cadran Zifferblatt Dial	11½"	Issued	04 Sep 2007	cm
		Modified	16.Aug.2007 ÄÄ 2480	cm
		Released	YES	
		Tolerance	+/- 20 µm	
		Scale	5 : 1 (A4V)	
RONDA	515.24D	Sous réserve de modifications Aenderungen vorbehalten Modifications reserved		
		No.	5010.573	02

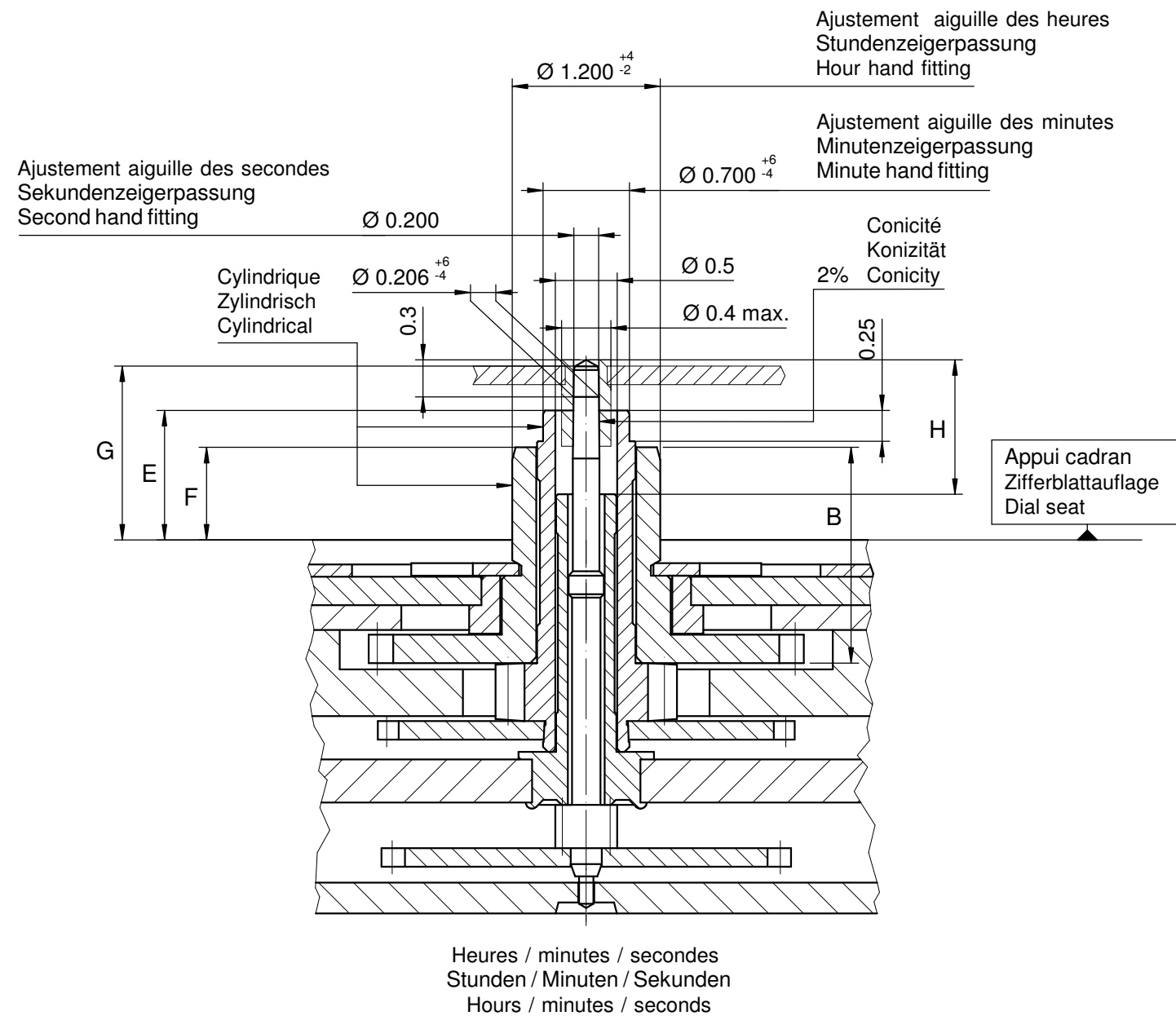

Aiguillage no Zeigerwerkhöhe Nr. Hand fitting height No	Dépassement Höhe über Zifferblattaufgabe Height over dial seat			Longueur Länge Length		Epaisseur max. (peinture comprise) Max. Dicke (inkl. Farbe) Max. thickness (paint included)			
	Pignon des secondes Sekundentrieb Second pinion	Chaussée Minutenrohr Cannon-pinion	Roue des heures Stundenrad Hour wheel			Cadran Zifferblatt Dial			Aiguilles Zeiger Hands
	G	F	F	H	B	Sous l'aiguille des secondes Unter Sekundenzeiger Under second hand	Sous l'aiguille des minutes Unter Minutenzeiger Under minute hand	Sous l'aiguille des heures Unter Stundenzeiger Under hour hand	
1	1.46	1.05	0.75	1.09	1.75	0.95	0.65	0.40	0.15
2	1.81	1.40	1.10	1.44	2.10	1.30	1.00	0.75	0.15

	Aig. des secondes Sekundenzeiger Second hand	Aig. des minutes Minutenzeiger Minute hand	Aig. des heures Stundenzeiger Hour hand	Lors de la pose d'aiguilles, le mouvement doit être soutenu. Beim Zeigersetzen muss das Werk abgestützt werden. The movement needs to be supported for hand setting.
mg max.	10	30	30	Masse / Masse / Weight *
µNm max.	0.08	0.70	0.70	Balourd / Unwucht / Unbalance *
gmm ² max.	0.4	-	-	Inertie / Massenträgheit / Inertia *
N max.	30	40	40	Force de chassage / Aufpresskraft / Force

Sous réserve de toutes modifications

Aenderungen vorbehalten

All modifications reserved

<h1>Aiguillages</h1> <h2>Zeigerwerkhöhen</h2> <h3>Hand fitting heights</h3>	10½", 11½"		
	Issued	10 Mär 1999	gd
	Modified	20 Apr 2011 ÄA 10340	ps
	Released	Yes	
	Tolerance	µm	
Scale	20 : 1 (A3H)		
RONDA 507, 509, 517, 519 505.24D, 515.24D	Sous réserve de modifications Aenderungen vorbehalten Modifications reserved		
	No.	3316.060	06

* En cas de données différentes, veuillez contacter le service après-vente

* Bei abweichenden Werten, bitte technischen Kundendienst anfragen

* In case of different values, please contact the customer service

Ajustement aiguille des secondes
Sekundenzeigerpassung
Second hand fitting

Ajustement aiguille des heures
Stundenzeigerpassung
Hour hand fitting

Ajustement aiguille des minutes
Minutenzeigerpassung
Minute hand fitting

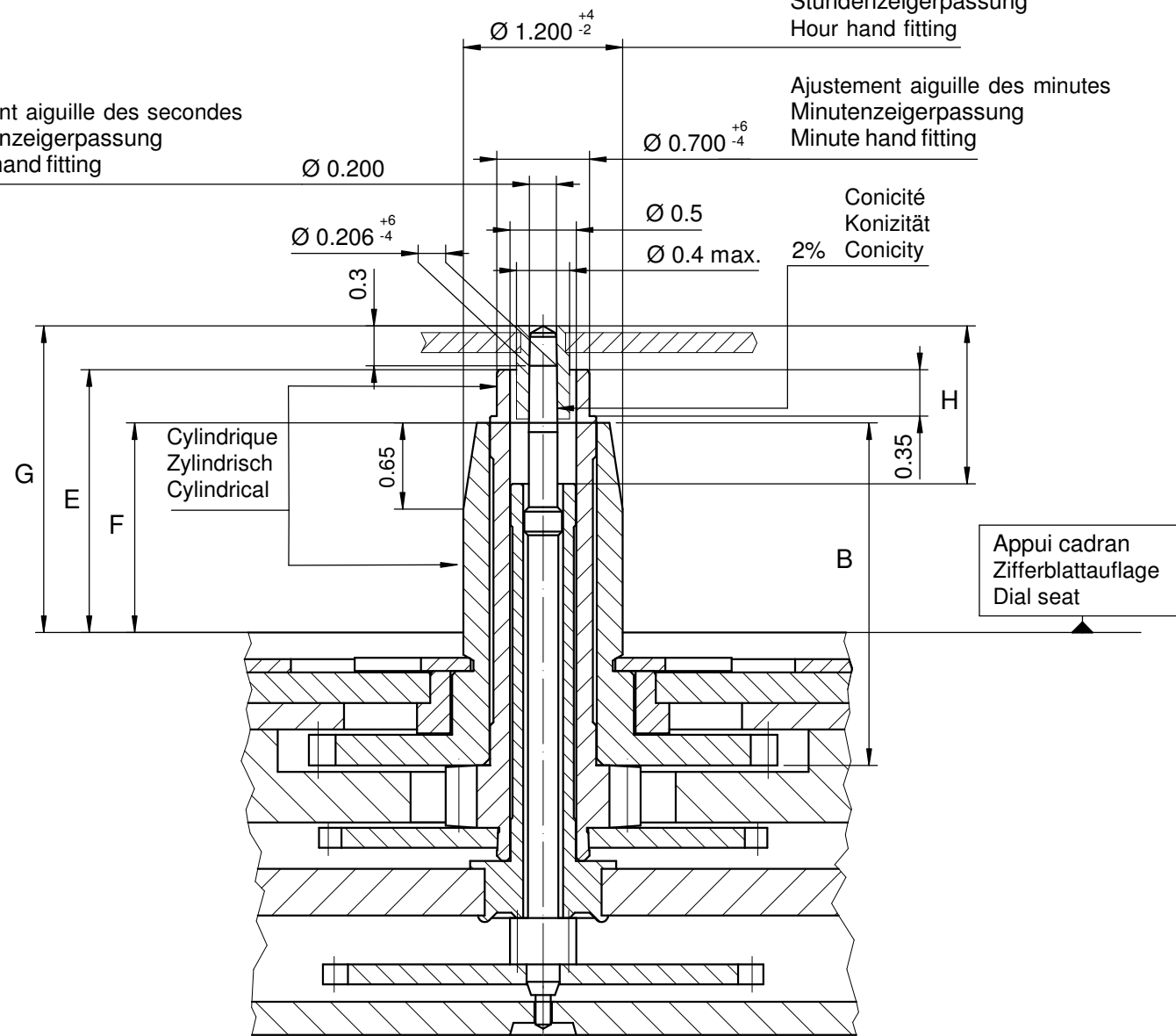

Heures / minutes / secondes
Stunden / Minuten / Sekunden
Hours / minutes / seconds

Aiguillage no ZeigerwerkhöheNr. Hand fitting height No	Dépassement Höhe über Zifferblattauflage Height over dial seat			Longueur Länge Length		Epaisseur max. (peinture comprise) Max. Dicke (inkl. Farbe) Max. thickness (paint included)			
	Pignon des secondes Sekundentrieb Second pinion	Chaussée Minutenrohr Cannon-pinion	Roue des heures Stundenrad Hour wheel		Roue des heures Stundenrad Hour wheel	Cadran Zifferblatt Dial			Aiguilles Zeiger Hands
	G	E	F	H	B	Sous l'aiguille des secondes Unter Sekundenzeiger Under second hand	Sous l'aiguille des minutes Unter Minutenzeiger Under minute hand	Sous l'aiguille des heures Unter Stundenzeiger Under hour hand	
6	2.31	1.98	1.58	1.19	2.58	1.80	1.55	0.40	0.15

	Aig. des secondes Sekundenzeiger Second hand	Aig. des minutes Minutenzeiger Minute hand	Aig. des heures Stundenzeiger Hour hand	Lors de la pose d'aiguilles, le mouvement doit être soutenu. Beim Zeigersetzen muss das Werk abgestützt werden. The movement needs to be supported for hand setting.
mg max.	10	30	30	Masse / Masse / Weight *
µNm max.	0.08	0.70	0.70	Balourd / Unwucht / Unbalance *
gmm ² max.	0.4	-	-	Inertie / Massenträgheit / Inertia *
N max.	30	40	40	Force de chassage / Aufpresskraft / Force

Sous réserve de toutes modifications

Aenderungen vorbehalten

All modifications reserved

Aiguillages
Zeigerwerkhöhen
Hand fitting heights

10 1/2", 11 1/2"

RONDA

507, 509, 517, 519
505.24D, 515.24D

Issued	23 Mai 2011	dh
Modified	24 Mai 2011 ÄA 11034	dh
Released	Yes	
Tolerance	µm	
Scale	20 : 1 (A3H)	
Sous réserve de modifications Aenderungen vorbehalten Modifications reserved		
No.	3316.157	00

* En cas de données différentes, veuillez contacter le service après-vente

* Bei abweichenden Werten, bitte technischen Kundendienst anfragen

* In case of different values, please contact the customer service

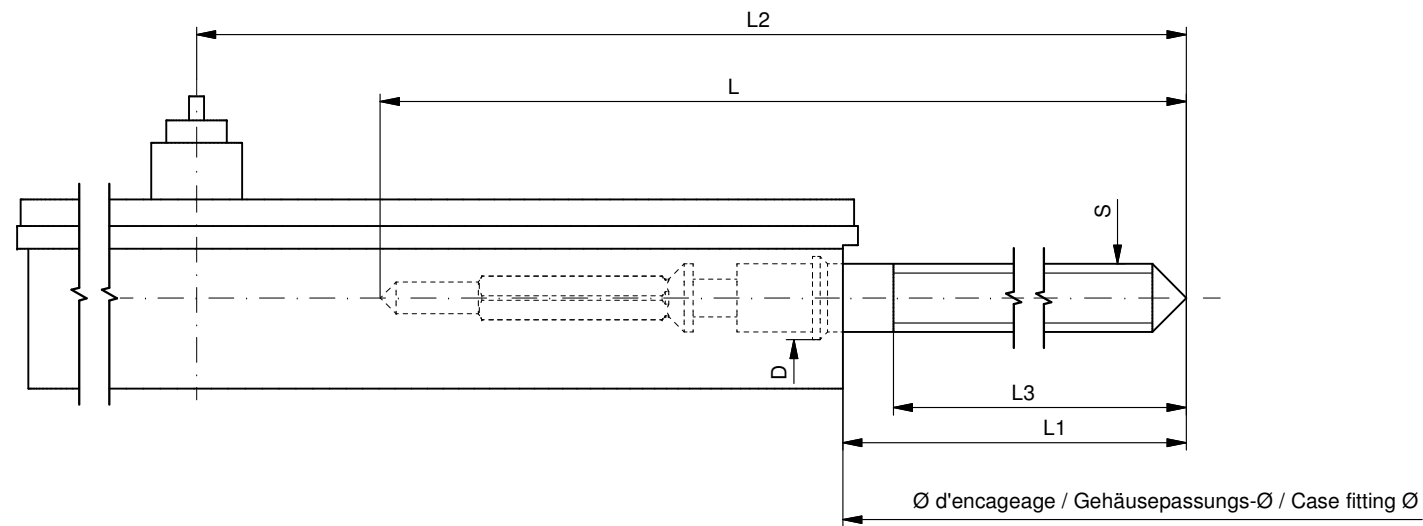

Tige de travail (intégrée dans le mouvement)
 Arbeitstellwelle (im Werk eingebaut)
 Working stem (implemented in the movement)

No. d'article Artikelnummer Part number	L	L1	L2	L3	S	D
3000.164.CO	20.50	9.92	22.72	11.83	0.90	1.05

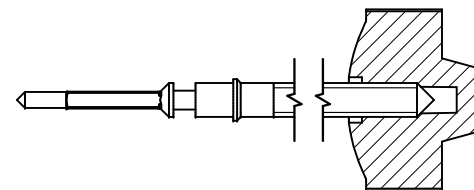

Couleur de la couronne Kronenfarbe Crown color	brun braun brown
Code	UN 8052

Tige (normale) / Stellwelle (normal) / Stem (normal)

No. d'article Artikelnummer Part number	L	L1	L2	L3	S	D
3000.164	20.50	9.92	22.72	11.83	0.90	1.05
3000.171	32.50	21.92	34.72	23.83	0.90	1.05

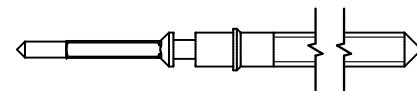

Tige (à arracher)
 Stellwelle (Ausreissversion)
 Stem (extractable version)

No. d'article Artikelnummer Part number	L	L1	L2	L3	S	D
3000.163	20.05	9.92	22.72	11.83	0.90	1.05
3000.196	32.50	21.92	34.72	23.83	0.90	1.05

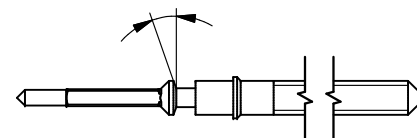

Rallonge de tige / Stellwelle Verlängerung / Stem extension

No. d'article Artikelnummer Part number	L4	L5 (min)	L6	S1	S2	D1
3000.040	12.00	1.90	2.60	0.90	0.90	1.35

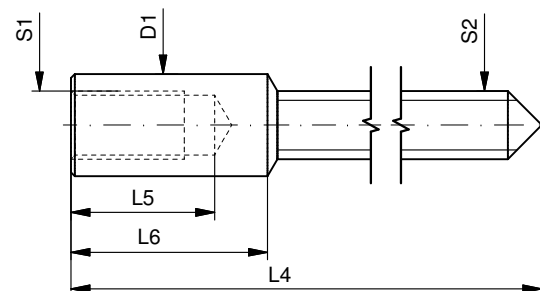

Couronne normale
 Normale Krone
 Normal crown

Boîte / Gehäuse / Case

0.02 - 0.10

Couronne vissée
 Geschraubte Krone
 Screwed crown

Force ⇐ min. Kraft ⇐ min. Force ⇐ min.	10 N
Force ⇐ max. Kraft ⇐ max. Force ⇐ max.	15 N

Tige Stellwelle Stem	(dimensions / forces) (Dimensionen / Kräfte) (dimensions / forces)		Issued	15 Aug 2012	ds5222	
	RONDA	512, 513, 513S, 515, 515S, 515.24H, 515.24D, 517, 519	Modified	17 Mär 2017	mg5224	
			Released	ÄA 34582		
			Tolerance	---		
			Scale	10:1 (A3)		
		Sous réserve de modifications Änderungen vorbehalten Modifications reserved		No.	5030.002	01

User's Manual English Movements Caliber

RONDA powertech

- 505.24D/515.24D
- 505.24H/515.24H
- 507/517
- 509/519

You have decided to buy a watch, which was assembled by a watchmaker using a Ronda movement. Please note that no watches are produced or distributed under the Ronda brand.

In case of repairs, guarantee claims and questions concerning the functioning of a watch, purchasers and consumers should contact their retailer or the watch manufacturer, for which the relevant information can be found in the sales or guarantee documentation provided with the watch.



Cal. 505.24D / 515.24D

Pos. I **Position of rest** (watch running)

Pos. II **Quick-change correction for date**

The date can also be corrected during the day-changing phase between 10 pm and midnight. The date of the following day has to be set, because no automatic date change takes place at midnight.

- Pull the crown out to position II (watch still running).
- Turn the crown clockwise until the required date appears.
- Push the crown back into position I.

Quick-change correction for 24-hour display

- Pull the crown out to position II (watch still running).
- Turn the crown anticlockwise until the desired time appears.
- Push the crown back into position I.

Pos. III **Setting the time**

- Pull the crown out to position III (watch stopped).
- Turn the crown, until the current time is displayed (remember the 24-hour cycle).
- Push the crown back into position I.



Cal. 505.24H / 515.24H



Cal. 507 / 517

Pos. I **Position of rest** (watch running)

Pos. II **Quick-change correction for date**

The date can also be corrected during the day-changing phase between 10 pm and midnight. The date of the following day has to be set, because no automatic date change takes place at midnight.

- Pull the crown out to position II (watch still running).
- Turn the crown until the required date appears.
- Push the crown back into position I.

Quick-change correction for day of the week

The blocking time for the day of the week quick-change correction is from approx. 10 pm and midnight.

- The second language always first appears around 24.00hrs for about 2 hours, until the display changes to the required language.
- Pull the crown out to position II (watch still running).
- Turn crown anticlockwise until the desired day of the week appears in the required language.
- Push the crown back into position.



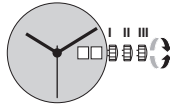

Cal. 507/517

Pos. III Setting the time

- Pull the crown out to position III (watch stopped).
- Turn the crown, until the current time is displayed (remember the 24-hour cycle).
- Push the crown back into position I.

Cal. 509/519

Pos. I Position of rest (watch running)

Pos. II Quick-change correction for date

The date display comprises a 2-disc system. For construction reasons, on the first day of a new month, the date must be set on 01 via the quick-change method passing through 31-39.

The date can also be changed during the day-changing phase between approx. 10 pm and midnight. The date of the following day has to be set, because no automatic date change takes place at midnight.

- Pull the crown out to position II (watch still running).
- Turn the crown clockwise until the required date appears.
- Push the crown back into position I.

Pos. III Setting the time

- Pull the crown out to position III (watch stopped).
- Turn the crown, until the current time is displayed (remember the 24-hour cycle).
- Push the crown back into position I.

Applies to all calibers:

Battery type: 371/SR920SW

Precision: +20/-10 seconds per month





11 1/2^{mm}

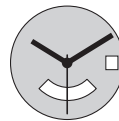

515.24D

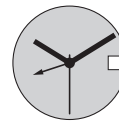

515.24H

Funktionen

Fonctions

Functions

Kaliber Calibre Caliber	Stellwellenpos. Pos. de tige Stem position	Funktionen Fonctions Functions
515.24	1	Normale Position / Position normale / Running position
	2	Datumkorrektur / 24-Stundenkorrektur Correction de la date / Correction 24 heures Date correction / 24 hours correction
	3	Zeiger stellen, Sekunden-Stopp mit Unterbruch der Motorimpulse Mise à l'heure, stop-seconde avec interruption des impulsions moteur Hand setting, stop-second with interruption of motor pulses

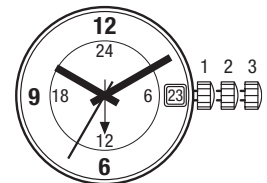
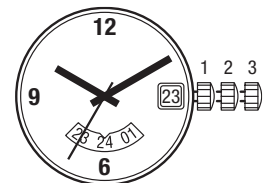

Batterie

Pile

Battery

Kaliber Calibre Caliber	Batterie Pile Battery	Spannung Voltage Tension	Artikelnummer RONDA Numero d'article RONDA Part number RONDA
515.24	371/SR920SW	1.55 V	3600.015.HGF

11 1/2''' 515.24H, 515.24D

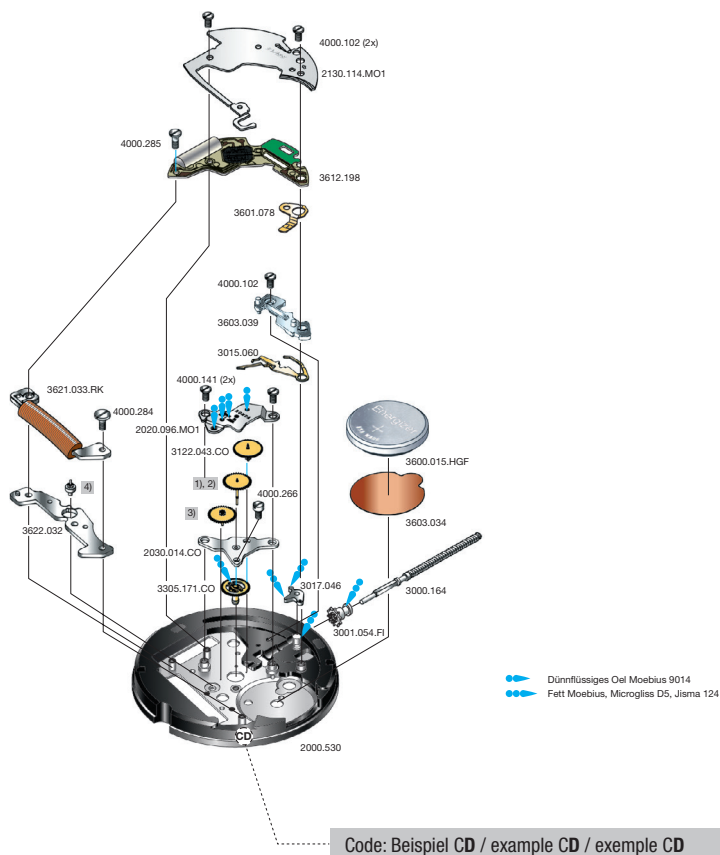

Cal. 515.24D	Werkseite / Côté mouvement / Movement side		
Plan No.	Bestandteile	Fournitures	Spare Parts
2000.530	Werkplatte	Platine	Main plate
2020.096.MO1	Räderwerkbrücke	Pont rouge	Train w. bridge
2030.014.CO	Zentrumbrücke	Pont centre	Centre bridge
2130.114.MO1	Modul-Abdeckp.	Couvre module	Module cover pl.
3000.164	Stellwelle	Tige	Stem
3001.054.FI	Kupplungstrieb	Pignon coulant	Sliding pinion
3015.060	Kuppl.-triebhebel	Bascule	Yoke
3017.046	Winkelhebel	Tirette	Setting lever
3122.043.CO	Kleinbodenrad	Roue moyenne	Third wheel
1)	Sekundenrad	Roue secondes	Second-wheel
3)	Zwischenrad	Roue interméd.	Intermed. wheel
3305.171.CO	Minutenrohr	Chaussée	Cannon pinion
3600.015.HGF	Batterie	Pile	Battery
3601.078	Batterie-Kontakt	Bride contact	Battery contact
3603.034	Batterie-Isolation	Isolateur pile	Battery insulation
3603.039	Deckplatte/ Ste.	Couvre mécan.	Setting lev. cover
3612.198	Modul	Module	Module
3621.033.RK	Spule	Bobine	Coil
3622.032	Stator	Stator	Stator
4)	Rotor	Rotor	Rotor
4000.102	Schraube	Vis	Screw
4000.141	Schraube	Vis	Screw
4000.266	Schraube	Vis	Screw
4000.284	Schraube	Vis	Screw
4000.285	Schraube	Vis	Screw

Abweichungen / Divergences / Deviations

Cal. 515.24H	Werkseite / Côté mouvement / Movement side		
Plan No.	Bestandteile	Fournitures	Spare Parts
A)	Sekundenrad	Roue secondes	Second-wheel
3305.180.CO	Minutenrohr	Chaussée	Cannon pinion

Cal. 515.24D		
	Bis Juni 2015 Jusqu' en Juin 2015 Untill June 2015	Ab Juli 2015 A partir de Juillet 2015 From July 2015
Code	2. Buchstabe ... C Second letter ... C 2 ^{ème} chiffre: ... C	2. Buchstabe: ab D Second letter: from D 2 ^{ème} chiffre: à partir de D
1)	3136.090.CO	3136.194.CO
3)	3147.019.CO	3147.092.CO
4)	3715.089.RK	3715.144.RK

Die obigen 3 Teile bilden jeweils eine Gruppe. Deshalb sind die 3 Teile jeder Gruppe nicht einzeln gegeneinander austauschbar.

Les 3 fournitures ci-dessous forment un groupe individuel. C'est pourquoi les 3 fournitures de chaque groupe ne sont pas interchangeables.

The 3 parts mentioned above are forming an individual group. Therefore the 3 parts of each group are not interchangeable.

Cal. 515.24H		
	Bis Juni 2015 Jusqu' en Juin 2015 Untill June 2015	Ab Juli 2015 A partir de Juillet 2015 From July 2015
Code	2. Buchstabe ... C Second letter ... C 2 ^{ème} chiffre: ... C	2. Buchstabe: ab D Second letter: from D 2 ^{ème} chiffre: à partir de D
2)	3136.095.CO	3136.218.CO
3)	3147.019.CO	3147.092.CO
4)	3715.089.RK	3715.144.RK

Die obigen 3 Teile bilden jeweils eine Gruppe. Deshalb sind die 3 Teile jeder Gruppe nicht einzeln gegeneinander austauschbar.

Les 3 fournitures ci-dessous forment un groupe individuel. C'est pourquoi les 3 fournitures de chaque groupe ne sont pas interchangeables.

The 3 parts mentioned above are forming an individual group. Therefore the 3 parts of each group are not interchangeable.

Werkaufbau

Assemblage

Assembling

11 1/2''' 515.24H

11 1/2''' 515.24D

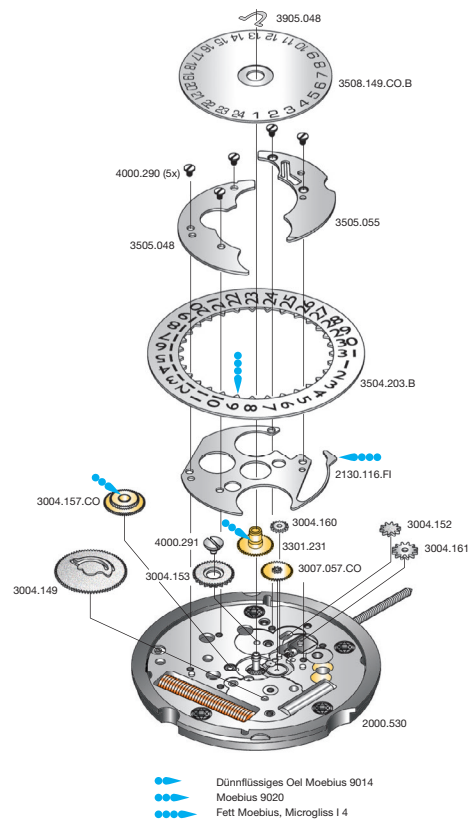
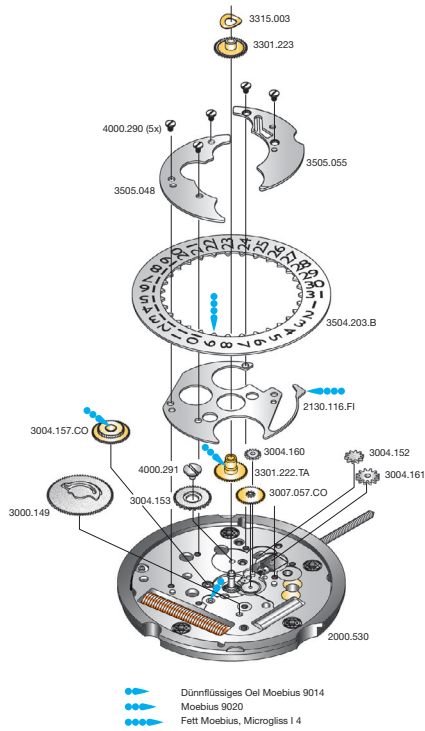

Cal. 515.24H	Zifferblattseite / Côté cadran / Dial side		
Plan No.	Bestandteile	Fournitures	Spare Parts
2130.116.FI	Kalenderplatte	Plaque calendrier	Date ind. plate
3004.160	Zeigerstellrad	Renvoi minuterie	Setting wheel
3004.149	Datummitn.-rad	Renvoi entraîin.	Ind. driving wheel
3004.161	Verbindungsrad-Kupplungtrieb	Renvoi pig. coulant	Slid. pin. sett. wh.
3004.152	Umkehrad	Baladeur	Correction wheel
3004.153	Korrekturrad	Roue correcteur	Correcteur wheel
3004.157.CO	Friktionsrad	Friction	Friction wheel
3007.057.CO	Wechselrad	Minuterie	Minute wheel
3301.222.TA	Stundenrad	Canon	Hour wheel
3301.223	Stundenrad	Canon	Hour wheel
3315.003	Spreifeder	Clinquant	Washer
3504.203.B	Datumsanzeiger	Baque	Date indicator
3505.055	Kalender-Abdeckplatte (Nr. 2)	Couvercle calendrier (no. 2)	Date indicator cover (no. 2)
3505.048	Kalender-Abdeckplatte (Nr. 1)	Couvercle calendrier (no. 1)	Date indicator cover (no. 1)
4000.290	Schraube	Vis	Screw
4000.291	Schraube	Vis	Screw

Cal. 515.24D	Zifferblattseite / Côté cadran / Dial side		
Plan No.	Bestandteile	Fournitures	Spare Parts
2130.116.FI	Kalenderplatte	Plaque calendrier	Date indicator pl.
3004.160	Zeigerstellrad	Renvoi minuterie	Setting wheel
3004.149	Dat.-Mitn.rad	Renvoi entraîneur	Ind. driving wh.
3004.161	Verbindungsrad-Kupplungtrieb	Renvoi pig. cou.	Sliding pin. set.
3004.152	Umkehrad	Baladeur	Sliding gear
3004.153	Korrekturrad	Roue corr. disque	Correcteur wheel
3004.157.CO	Friktionsrad	Friction	Friction wheel
3007.057.CO	Wechselrad	Minuterie	Minute wheel
3301.231.TA	Stundenrad	Canon	Hour wheel
3504.203.B	Datumsanzeiger	Baque	Date indicator
3505.048	Kalender- Abdeckplatte (Nr. 1)	Couvercle calendrier (no. 1)	Date indicaor cover (no. 1)
3505.055	Kalender- Abdeckplatte (Nr. 2)	Couvercle calendrier (no. 2)	Date indicaor cover (no. 2)
3508.149.CO.B	24 Std.-Scheibe	Disque 24 h	24 h indicator
3905.048	Klemmfeder für Tagesscheibe	Clavett disque	Disc spring clip
4000.290	Schraube	Vis	Screw
4000.291	Schraube	Vis	Screw

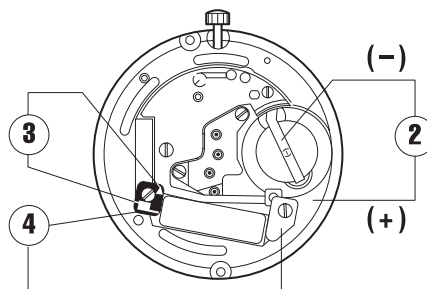
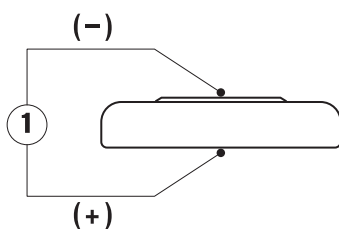

Kaliber Calibre Caliber	Pos. Pos. Pos.	Einheit Unité Unit	Messwerte Valeurs mesurées Measured values	Kontrolle Contrôle Check	Bemerkungen Remarques Remarks
515.24H 515.24D	1	V	1,55	Batterie-Spannung Tension de la pile Battery voltage	Batterie herausnehmen und messen Enlever et mesurer la pile Remove battery for measuring
515.24H 515.24D	2	µA	1,10–1,85	Stromaufnahme Consom. de courant Power consumption	Ohne Batterie, mit externer Speisung Sans pile, avec alimentation externe Without battery, with external power supply
515.24H 515.24D	2	V	≤ 1,30	Funktionskontrolle bei Minimalspannung Contrôle de fonctionnement à tension minimale Check with lowest possible voltage	Ohne Batterie, mit externer Speisung Sans pile, avec alimentation externe Without battery, with external power supply
515.24H 515.24D	3	KΩ	1,90–2,10	Spulenwiderstand Résistance de la bobine Resistance of the coil	Ohne Batterie Sans pile Without battery
515.24H 515.24D	4	KΩ	∞	Spulenisolation Isolation de la bobine Coil insulation	Ohne Batterie Sans pile Without battery
515.24H 515.24D		Sek./Monat sec./mois sec./month	- 10/+ 20	Induktivsonde 60 Sek. Senseur inductif 60 sec. Inductive sensor 60 sec.	Mit Batterie Avec pile With battery

Einschalen / Werkzeuge

Emboîtage / outils

Casing / tools

Nr. H 51X.1A



Nr. H 51X.1T



SWISS MADE & SWISS PARTS	
Schraube Vis Screw	

Zeigersetzen

Maximale Aufpresskraft:

- Stunden und Minutenzeiger: max. 40N
- Sekundenzeiger: max. 30N

Beim Zeigersetzen muss das Werk abgestützt werden.

Poser les aiguilles

Force de chassage maximale:

- Aiguilles des heure et des minutes: max. 40N
- Aiguille des secondes: max. 30N

Lors de la pose d'aiguilles, le mouvement doit être soutenu.

Hand setting

Maximal force:

- Hour and minute hands: max. 40N
- Second hand: max. 30N

The movement needs to be supported for hand setting.

Kal. 515.24H, 515.24D
Stellwelle entfernen

Beim Entfernen der Stellwelle muss sich die Stellwelle in **Position 2** befinden, bevor auf den Winkelhebel gedrückt wird.

Cal. 515.24H, 515.24D
Enlever la tige

Enlevant la tige, la tige doit se trouver en **position 2**, avant de pousser sur la tirette.

Cal. 515.24H, 515.24D
Stem removal

For removal of the stem, the stem must be in **position 2** prior to apply pressure to the setting lever.