



7 3/4''' ETA 956.112

CT 956112 ESI 492798 10 16.03.2015

7 3/4''' Ø 17,20 mm

Movement height	Altura sobre máquina	Altezza sopra movimento	2,50 mm
Height on battery	Altura sobre pila	Altezza sopra pila	2,65 mm
Number of jewels	Número de piedras	Numero di pietre	7
Frequency	Frecuencia	Frequenza	32'768 Hz

Movement height	Altura sobre máquina	Altezza sopra movimento	2,50 mm
Height on battery	Altura sobre pila	Altezza sopra pila	2,65 mm
Number of jewels	Número de piedras	Numero di pietre	7
Frequency	Frecuencia	Frequenza	32'768 Hz

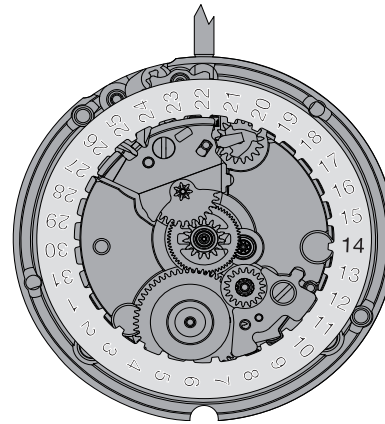
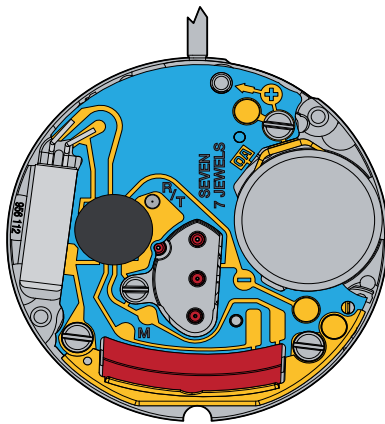

The repair and reconditioning work must only be performed by properly trained personnel.
Las tareas de reparación y revisión sólo deben ser llevadas a cabo por personal debidamente formado.
I lavori di riparazione e di revisione devono essere eseguiti esclusivamente da personale adeguatamente formato.



General information



Before starting work, please study this "Technical communication" carefully.



Eye protection is obligatory for all operations / work on the movement!



ETA SA disclaims any liability in case of damage arising from failure to observe this "Technical communication".

Environmental protection requirements



The legal provisions relating to waste handling and disposal must be observed in all operations / work on the movement!

In particular, lubricating and cleaning products harmful to the environment must be disposed of in accordance with the rules!



Substances prone to cause water pollution must be stored, transported, collected and disposed of in appropriate vessels.

Under no circumstances must they pollute the soil or be poured into sewage systems!

Explanation of symbols



Caution! Risk of material damage!

Below are some obligatory instructions for preventing any material damage!



Below is some advice for use and important information.

Información general



Esta "Comunicación técnica" deberá estudiarse muy bien **antes** de comenzar los trabajos.



Es obligatorio utilizar protección ocular para todos los trabajos en y con el reloj.



ETA SA no se hace responsable de los daños provocados como consecuencia de la inobservancia de esta "Comunicación técnica".

Normas de protección medioambiental



Deberá cumplirse la normativa legal relativa al reciclaje y la eliminación correctos de los residuos en todos los trabajos en y con el reloj.

En especial, deberán eliminarse correctamente los productos lubricantes y de limpieza peligrosos para el medio ambiente.



Las sustancias contaminantes del agua deben recogerse, almacenarse, transportarse y eliminarse en recipientes adecuados.

En ningún caso se permitirá que contaminen el suelo o que lleguen a la canalización.

Significado de los símbolos



Atención Peligro de daños materiales

Instrucciones que deberán respetarse necesariamente para evitar daños materiales.



Consejos de aplicación e información importantes.

Informazioni generali



Questa "Comunicazione Tecnica" deve essere studiata attentamente **prima** dell'inizio dei lavori.



Per tutti i lavori su e con il movimento dell'orologio è obbligatorio proteggere gli occhi!



ETA SA declina qualunque responsabilità per eventuali danni causati dalla mancata osservanza della presente "Comunicazione tecnica".

Disposizioni relative alla protezione ambientale



Per tutti i lavori su e con il movimento dell'orologio si dovranno rispettare le disposizioni di legge relative al corretto riciclaggio e smaltimento dei rifiuti!

In particolare si dovrà provvedere al corretto smaltimento di lubrificanti e detergenti nocivi per l'ambiente!



Le sostanze inquinanti per l'acqua devono essere conservate, trasportate, raccolte e smaltite in contenitori adatti.

Queste non devono inquinare il terreno o arrivare nelle canalizzazioni!

Spiegazione dei simboli



Attenzione! Pericolo di danni materiali!

Seguono importanti indicazioni che devono essere tassativamente rispettate per evitare danni materiali!



Seguono consigli per l'uso e informazioni importanti.

List of components - Lista de piezas - Lista fornitori

Pos	Article number Número de artículo Numero articolo		List of components	Lista de piezas	Lista fornitori
1	Var		Main plate, assembled	Platina, montada	Piastra, montata
1-1	7613226056893	2x	Dial fastener	Sujetador de esfera	Ferma-quadrante
1-2	7613226008885		Stator	Estátor	Statore
1-3	7613226040724		Rivet for stator	Remache del estátor	Ribattino dello statore
2	7613226001572		Sliding pinion	Piñón corredizo	Pignone scorrevole
3	Var		Handsetting stem	Tija de puesta en hora	Albero di messa all'ora
4	7613226007994		Double corrector operating lever	Mando del corrector doble	Comando del correttore doppio
5	7613226009370		Setting lever, assembled	Tirete, montado	Tiretto, montato
6	7613226051997		Setting lever spring-clip	Chaveta de tirete	Chiavetta del tiretto
7	7613226056848		Setting lever jumper	Muelle flexible de tirete	Scatto del tiretto
8	7613226048317		Rotor	Rotor	Rotore
9	7613226031098		Third wheel	Rueda primera	Ruota mediana
10	Var		Second wheel	Rueda de segundos	Ruota dei secondi
11	7613226043794		Intermediate wheel, assembled	Rueda intermedia, montada	Ruota intermedia, montata
12	Var		Train wheel bridge, jewelled	Puente de rodaje empedrado	Ponte del ruotismo con pietre
13	7613226014299		Centre second stop lever	Palanquita de parada de segundos al centro	Leva d'arresto dei secondi al centro
14	7613226047273		Battery insulator	Aislante de pila	Isolatore della pila
15	7613226090934		Electronic module	Módulo electrónico	Modulo elettronico
16	Var		Cannon pinion with driving wheel	Cañón de minutos con arrastrador	Pignone calzante con conduttore
17	7613226011212		Minute wheel, assembled	Rueda de minutería, montada	Ruota della minutería, montata
18	7613226041097		Setting wheel	Rueda de transmisión	Rinvio
19	7613226053991		Date corrector, assembled	Corrector de fecha, montada	Correttore della data, montata
20	7613226055292		Yoke	Báscula de piñón corredizo	Bascula del pignone scorrevole
21	7613226004719		Minute train bridge	Puente de rodaje de minutería	Ponte del ruotismo di minutería
22	Var		Date indicator	Indicador de fecha	Indicatore della data
23	7613226016569		Date indicator driving wheel, assembled	Rueda de arrastre del indicador de fecha, montada	Ruota conduttrice dell'indicatore della data, montata
24	7613226003668		Intermediate date wheel	Palanquita de parada e interruptor	Leva di arresto e interruttore
25	7613226047648		Date jumper	Muelle flexible de fecha	Scatta-data
26	7613226047037		Date jumper maintaining plate	Placa de sujeción del muelle flexible de fecha	Placca di guardia dello scatta-data
27	Var		Hour wheel, assembled	Rueda de horas, montada	Ruota delle ore, montata
28	7613226006898		Hour wheel spring-clip	Chaveta de rueda de horas	Chiavetta della ruota delle ore
29	Var		Battery	Pila	Pila
30	7613226017276		Battery limiting spring	Muelle de limitación de pila	Molla di limitazione della pila
900	7613226108462	1x	Cylindrical head screw - Pos. 12: Screw for train wheel bridge	Tornillo de cabeza cilíndrica - Pos. 12: Tornillo del puente de rodaje	Vite a testa cilíndrica - Pos. 12: Vite del ponte del ruotismo
901	7613226108653	2x	Cylindrical head screw - Pos. 15: Screw for electronic module, long	Tornillo de cabeza cilíndrica - Pos. 15: Tornillo de módulo electrónico, largo	Vite a testa cilíndrica - Pos. 15: Vite del modulo elettronico, lunga
902	7613226123816	1x	Cylindrical head screw - Pos. 15: Screw for electronic module, short	Tornillo de cabeza cilíndrica - Pos. 15: Tornillo de módulo electrónico, corto	Vite a testa cilíndrica - Pos. 15: Vite del modulo elettronico, corta
903	7613226088597	1x 1x	Countersunk head screw - Pos. 21: Screw for minute train bridge - Pos. 26: Screw for date jumper main- taining plate	Tornillo de cabeza cónica - Pos. 21: Tornillo del puente de rodaje de minutería - Pos. 26: Tornillo de placa de sujeción del muelle flexible de fecha	Vite a testa conica - Pos. 21: Vite del ponte del ruotismo di minutería - Pos. 26: Vite della placca di guardia dello scatta-data

Interchangeability and variants can be found on the ETA ONLINE SHOP (EOS):

www.eta.ch

→ Support Center
→ Support Center Portal

La intercambiabilidad y las variantes se encuentran en ETA ONLINE SHOP (EOS):

www.eta.ch











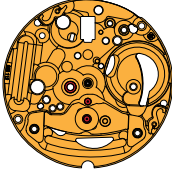















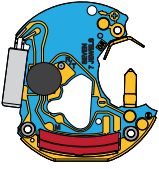





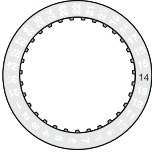

→ Support Center
→ Support Center Portal

L'intercambiabilità e le varianti si trovano sul ETA ONLINE SHOP (EOS):

www.eta.ch

→ Support Center
→ Support Center Portal

Materials - Fornituras - Forniture

								
1 Var	1-1	1-2	1-3	2	3 Var	4	5	
								
6	7	8	9	10 Var	11	12 Var	13	14
								
15	16 Var	17	18	19	20	21	22 Var	
								
23	24	25	26	27 Var	28	29 Var	30	
								
900	901	902	903					

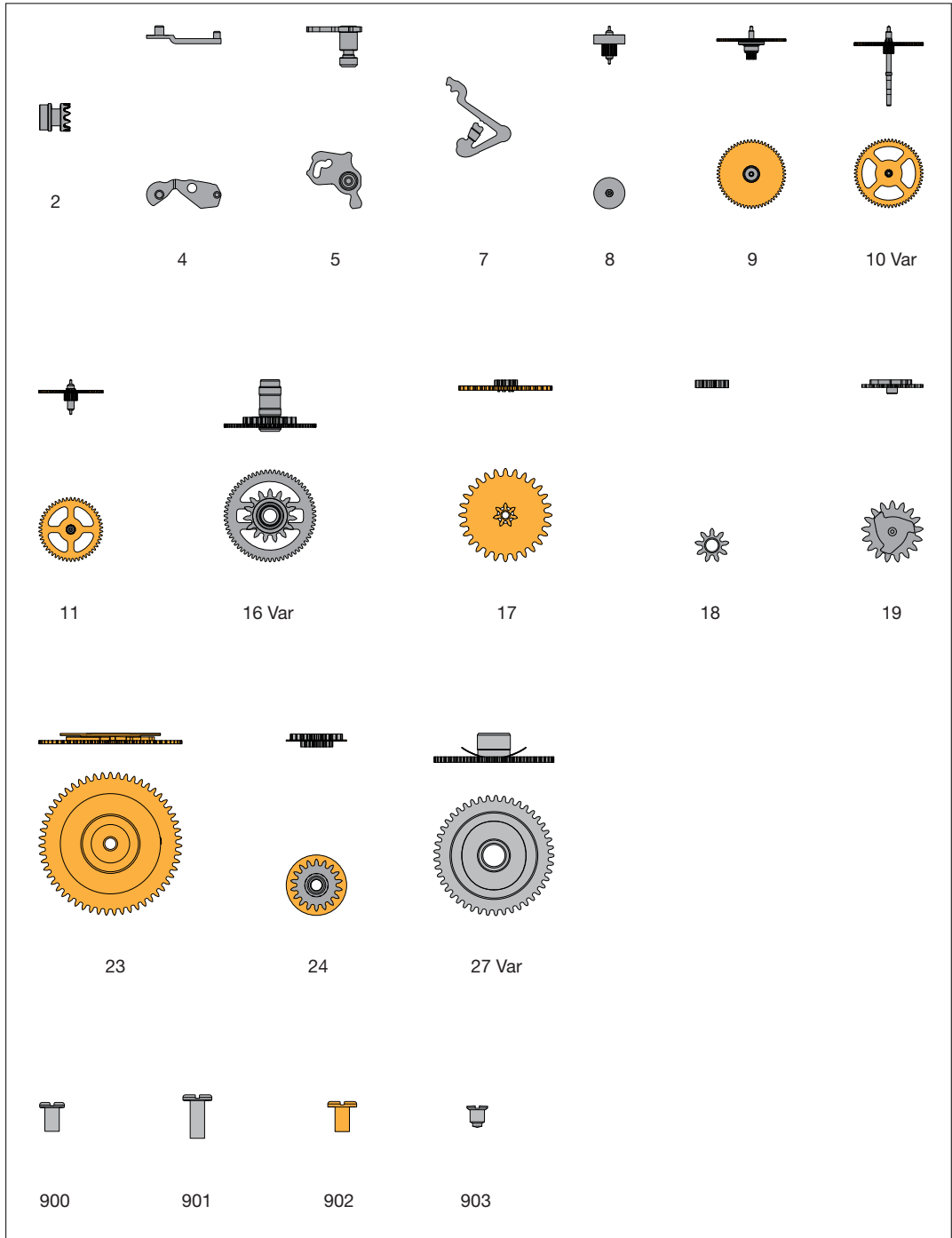

Order of assembly - Orden del montaje - Ordine dell'assemblaggio:
 Handsetting mechanism - Mecanismo de puesta en hora - Meccanismo della messa all'ora

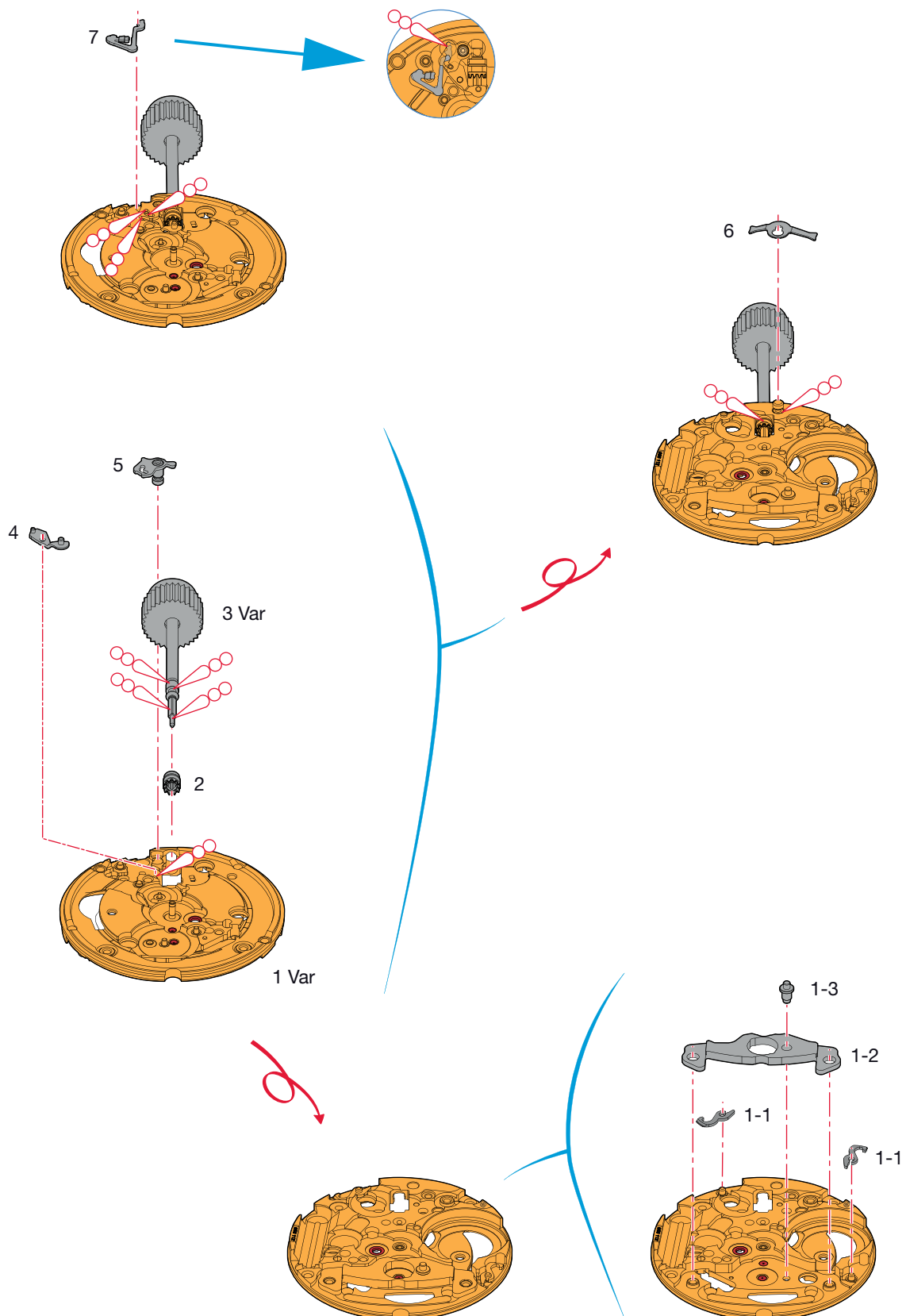

Assembling of the handsetting mechanism

(Parts listed in order of assembly)

Montaje del mecanismo de puesta en hora

(Lista de fornituras por orden de ensamblado)

Montaggio del meccanismo della messa all'ora

(Elenco delle forniture in ordine di montaggio)

1 Var	4	7
2	5	
3 Var	6	

Lubrication - Lubricación - Lubrificazione

Thick oil or grease
Aceite espeso o grasa
Olio denso o grasso

Moebius
HP-1300
or / ó / o
Moebius D5

Order of assembly - Orden del montaje - Ordine dell'assemblaggio:
Basic movement - Máquina de base - Movimento di base

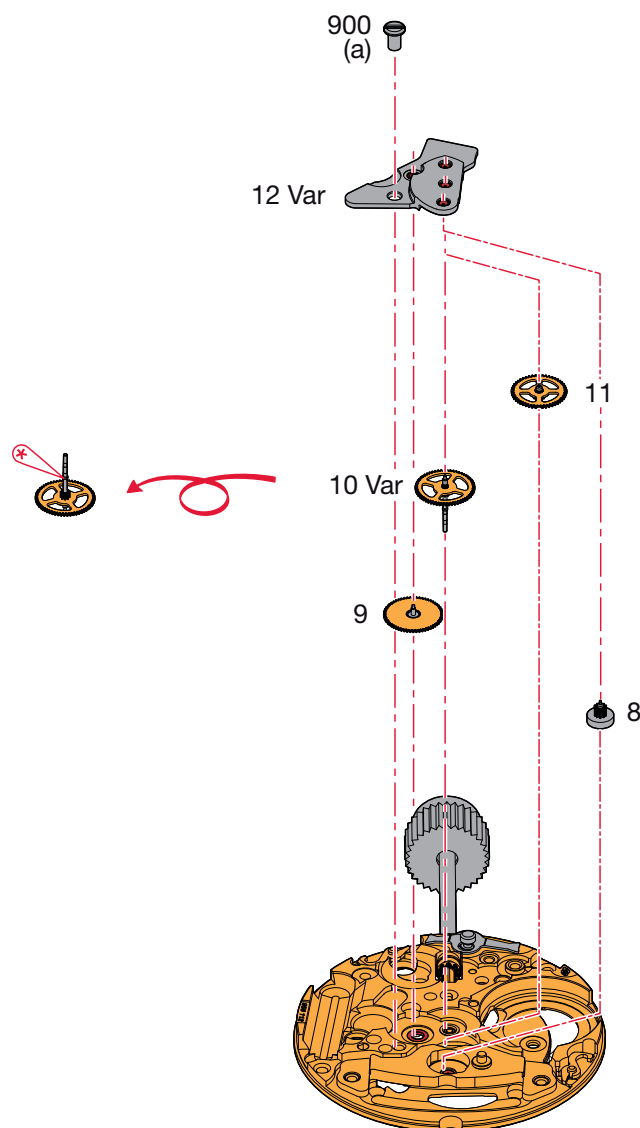

Assembling of the basic movement

(Parts listed in order of assembly)

Montaje de la máquina de base

(Lista de fornituras por orden de ensamblado)

Montaggio del movimento di base

(Elenco delle forniture in ordine di montaggio)

8	10 Var	12 Var
9	11	900

Lubrication - Lubricación - Lubrificazione

	Very small quantity	Moebius 9014
	Cantidad muy pequeña	or / ó / o
	Piccolissima quantità	Moebius 9034

M_L Minimum torque for loosening**M_L Par mínimo para desatornillar****M_L Coppia minima per svitare**

(a) 0,7 Ncm

Order of assembly - Orden del montaje - Ordine dell'assemblaggio:
Electronic module - Módulo electrónico - Modulo elettronico

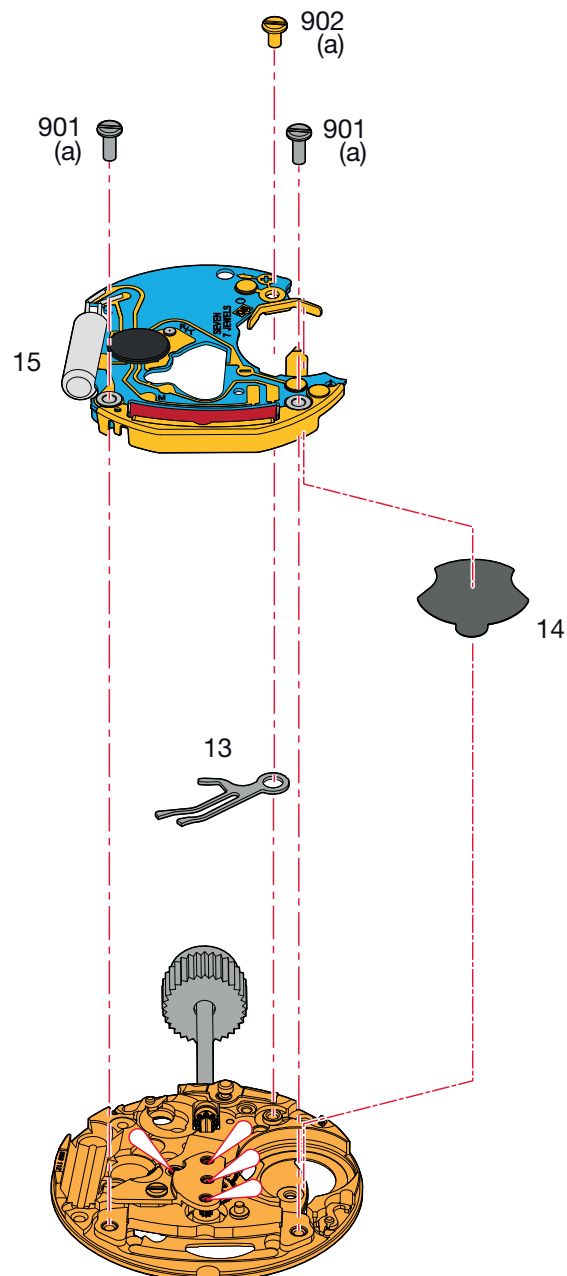

Assembling of the electronic module

(Parts listed in order of assembly)

Montaje del módulo electrónico

(Lista de fornitureas por orden de ensamblado)

Montaggio del modulo elettronico

(Elenco delle forniture in ordine di montaggio)

13	15	902
14	901 (2x)	

Lubrication - Lubricación - Lubrificazione

	Fine oil	Moebius 9014
	Aceite fino	or / ó / o
	Olio fluido	Moebius 9034

M_L Minimum torque for loosening**M_L Par mínimo para desatornillar****M_L Coppia minima per svitare**

(a) 0,7 Ncm

Order of assembly - Orden del montaje - Ordine dell'assemblaggio:
 Calendar mechanism - Mecanismo de calendario - Meccanismo di calendario

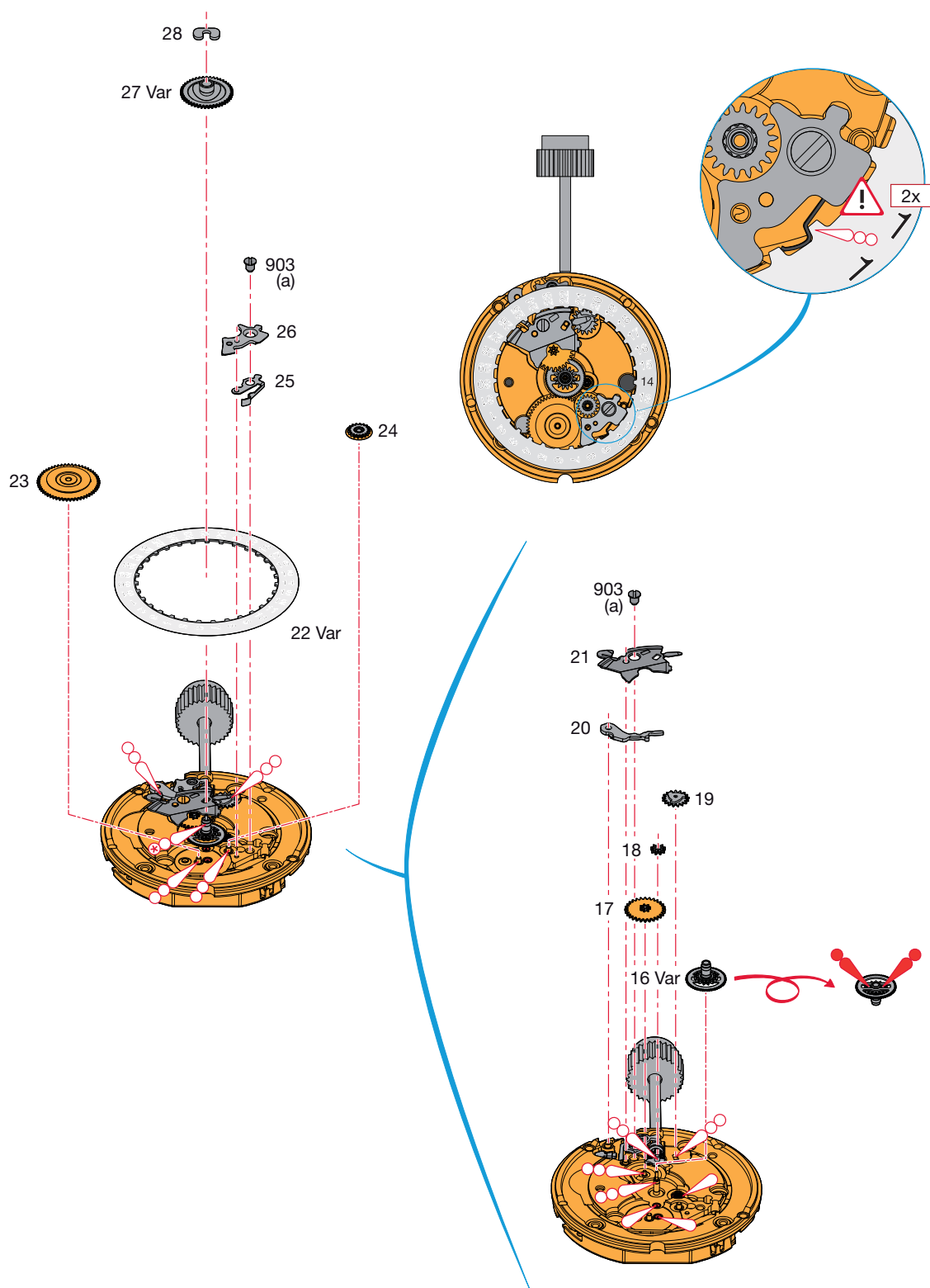

Assembling of the calendar mechanism

(Parts listed in order of assembly)

Montaje del mecanismo de calendario

(Lista de fornituras por orden de ensamblado)

Montaggio del meccanismo del calendario

(Elenco delle forniture in ordine di montaggio)

16 Var	21	25
17	903 (1x)	26
18	22 Var	903 (1x)
19	23	27 Var
20	24	28

Lubrication - Lubricación - Lubrificazione

Fine oil
Aceite fino
Olio fluido

Moebius 9014
or / ó / o
Moebius 9034



Thick oil or grease
Aceite espeso o grasa
Olio denso o grasso

Moebius HP-1300
or / ó / o
Moebius D5



Grease
Grasa
Grasso

Moebius 9501
or / ó / o
Jismaa 124



Very small quantity
Cantidad muy pequeña
Piccolissima quantità

Moebius HP-1300
or / ó / o
Moebius D5



- | | |
|--|---|
| | Lubricate part pos. 25.
1. Lubrique la pieza pos. 25 .
Lubrificare il pezzo pos. 25. |
| | Rotate part pos. 22 approx 10 teeth with rapide correction.
2. Gire la pieza pos. 22 unos dientes con la corrección rápida.
Ruotare il pezzo pos. 22 di circa 10 denti con la correzione rapida. |
| | Lubricate again part pos. 25.
3. Lubrique de nuevo la pieza pos. 25.
Lubrificare di nuovo il pezzo pos. 25. |
| | Rotate part pos. 22 approx 10 teeth with rapide correction again.
4. Gire de nuevo la pieza pos. 22 unos 10 dientes con la corrección rápida.
Ruotare di nuovo il pezzo pos. 22 di circa 10 denti con la correzione rapida. |

M_L Minimum torque for loosening**M_L Par mínimo para desatornillar****M_L Coppia minima per svitare**

(a) 0,7 Ncm

Order of assembly - Orden del montaje - Ordine dell'assemblaggio:
Battery - Pila - Pila

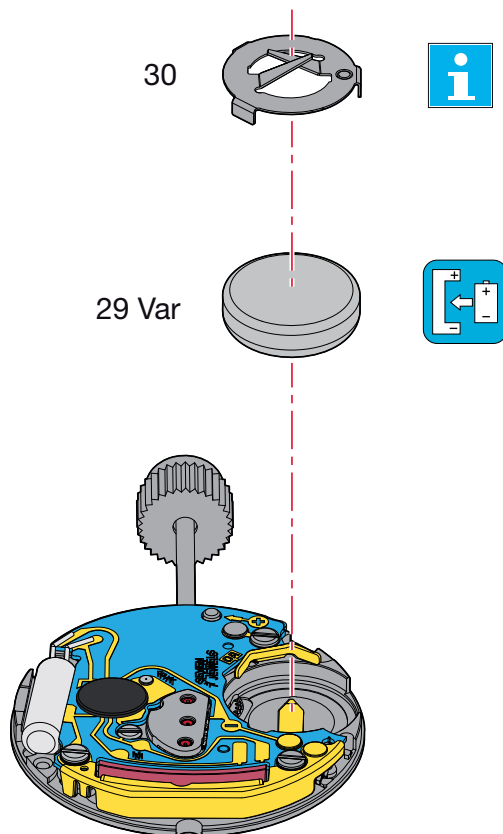

Assembling of the battery

(Parts listed in order of assembly)

Montaje de la pila

(Lista de forniture por orden de ensamblado)

Montaggio pila

(Elenco delle forniture in ordine di montaggio)

29 Var

30

Pos. 30:

To be fitted when the clearance between the movement and the case back is too great.



Necesario, si la seguridad entre el movimiento y el fondo de la caja es demasiado elevada.

Necessario quando la sicurezza tra il movimento e il fondo della cassa è troppo elevata.

Electrical tests - Controles eléctricos - Controlli elettrici

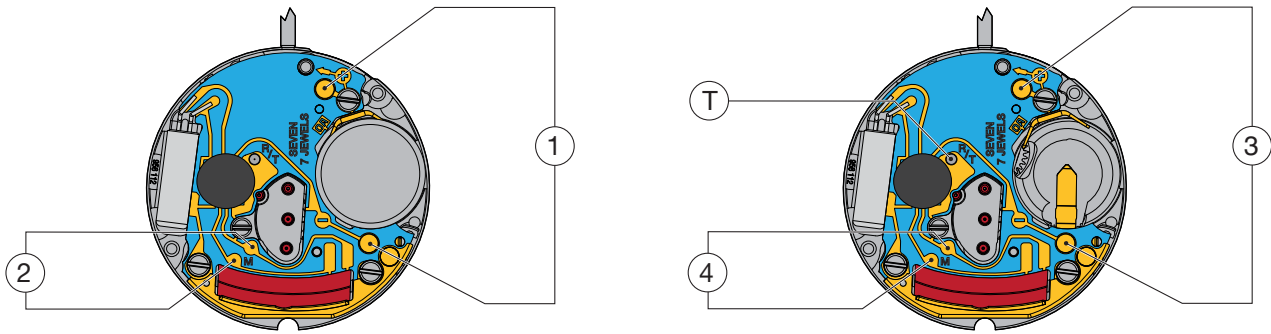

Position Posición Posizione	Setting of apparatus Escala de medición Scala di misura	Measurement Medición Misura	Test Control Controllo	Remarks Notas Osservazioni
1	2 V ($R_i \geq 10 \text{ k}\Omega/\text{V}$)	1,55 V	Battery voltage Tensión de la pila Tensione della pila	Measurement with battery. Medición con pila. Misura con pila.
	2 V	4 steps jump every 4 sec., when feed voltage < 1.30 V.	EOL function. End of life test for the battery.	Measurement without battery, with feed voltage < 1.30 V, EOL –function after about 2 min.
		Salto de 4 pasos cada 4 segundos, con tensión de alimentación < 1,30 V.	Función EOL. Prueba de indicación de fin de vida de la pila.	Medición sin pila, con tensión de alimentación < 1,30 V, EOL –funcionamiento después de 2 minutos.
		Scatto di 4 passi ogni 4 secondi quando la tensione e di un alimentazione < 1,30 V.	Funzione EOL. Prova dell'indicazione di fine vita della pila.	Misura senza pila, con tensione di alimentazione < 1,30 V, EOL –funzionamento dopo 2 minuti.
2	1 V ($R_i \geq 10 \text{ k}\Omega / \text{V}$)	Hand of the measuring apparatus oscillates in + and – direction. La aguja del multimetro oscila en sentido + y –. La lancetta del multimetro oscilla nel senso + e –.	Impulses at output of integrated circuit: Frequency 1/s. Impulsos a la salida del circuito integrado: Frecuencia 1/s. Impulsi all'uscita del circuito integrato: Frequenza 1/s.	Measurement with controlled battery. Medición con pila controlada. Misura con pila controllata.
3	2 V	$\leq 1,30 \text{ V}$ Connect R/T point with the – conductor. Motor driven with 8 steps/s at 1.55 V and 32 steps/s with voltage $\leq 1,30 \text{ V}$ (EOL). Conectar el punto R/T con la pista –. Mando del motor con 8 pasos/s a 1,55 V y 32 pasos/s con tensión $\leq 1,30 \text{ V}$ (EOL). Mettere in contatto il punto R/T con il punto –. Comando del motore con 8 passi/s a 32 passi/s con tensione $\leq 1,30 \text{ V}$ (EOL).	Lower working–voltage limit. Limite inferior de la tensión de funcionamiento. Limite inferiore della tensione di funzionamento.	Measurement without battery, with variable external power supply, starting with 1.55 V, lower tension until movement stops. Medición sin pila, con alimentación exterior variable bajando de 1,55 V hasta la parada de la máquina. Misura senza pila con alimentazione esterna variabile, scendendo da 1,55 V fino all'arresto del movimento.
	10 μA	$\leq 1,10 \mu\text{A}$	Consumption of movement. Consumo de la máquina. Consumo del movimento.	Measurement without battery, with external power supply 1.55 V. Medición sin pila, con alimentación exterior de 1,55 V. Misura senza pila con alimentazione esterna di 1,55 V.
		$\leq 0,5 \mu\text{A}$	Function of stop lever, pos. 3 of handsetting. Funcionamiento del interruptor en pos. 3 de la tija de puesta en hora. Funzionamento dell'interruttore in pos. 3 dell'albero di massa all'ora.	Measurement without battery, with external power supply 1.55 V. Medición sin pila, con alimentación exterior de 1,55 V. Misura senza pila con alimentazione esterna di 1,55 V.
4	$\sim 10 \text{ k}\Omega$ 200 μA	1,7–2,1 $\text{k}\Omega$ 95–118 μA	Resistance of motor coil. Resistencia de la bobina del motor. Resistenza della bobina motore.	

Position Posición Posizione	Setting of apparatus Escala de medición Scala di misura	Measurement Medición Misura	Test Control Controllo	Remarks Notas Osservazioni
	<i>Ohmmeter with a test voltage exceeding 0.40 V unsuitable, recommended voltage 0.20 V. Ohmiómetros con tensión de medición superior a 0,40 V inapropiados; tensión recomendada 0,20 V Ohmmetri con tensione di misura superiore a 0,40 V sono inadeguati; tensione raccomandata 0.20 V</i>			

*The test must be conducted at an ambient temperature of between 20°C and 25°C.
Las pruebas deben realizarse a una temperatura ambiente comprendida entre 20°C y 25°C.
I test devono essere effettuati a temperatura ambiente compresa tra 20°C e 25°C.*

Fitting the battery

Slide the battery against the contact strip
①. Press the battery firmly into its
mounting ②. The contact strip keeps the
battery in position.

*The tweezers must not be electrically con-
ductive!*

Colocación de la pila

Colocar la pila debajo de las dos lengüetas
metálicas del cobre-módulo ①. Apretar la
pila al fondo de su alojamiento ②. El dedo
del cobre-módulo sujeta la pila en
su sitio.

*Las pinzas no deben ser conductoras de la
electricidad!*

Posa della pila

Far scivolare la pila sotto le due linguette
metalliche del copri-módulo ①. Premere
la pila al fondo del suo alloggiamento ②. Il dito
del copri-módulo mantiene la pila nella sua
posizione.

La pinzetta non deve condurre elettricità!

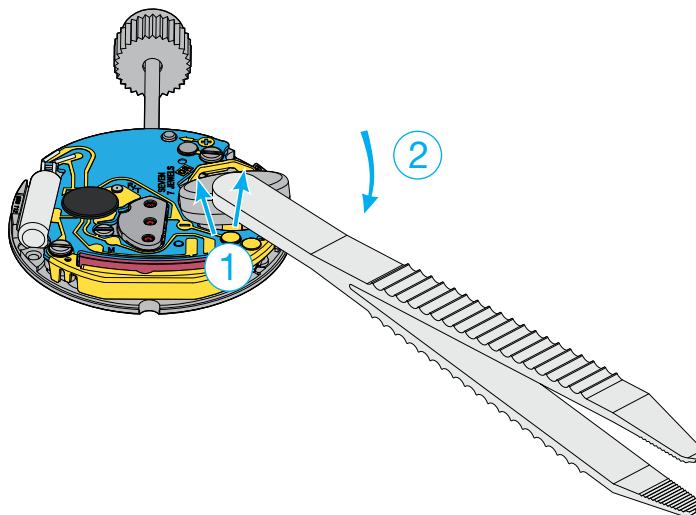

Removing the battery

Insert tweezers ① between main plate
and battery (see drawing) and lift out the
battery by gently lifting back ②. Remove
the battery ③.

*The tweezers must not be electrically con-
ductive!*

Retiro de la pila

Insertar unas pinzas ① entre el módulo y
la pila (véase dibujo) y palanquear la pila
apartando cuidadosamente el dedo del
cobre-módulo ②. Sacar la pila ③.

*Las pinzas no deben ser conductoras de la
electricidad!*

Ritiro della pila

Far scivolare una pinzetta ① tra il modulo
e la pila (vedi disegno) e fare leva sotto
quest'ultima allargando leggermente il dito
di sostegno verso dietro ②.
Ritirare la pila ③.

La pinzetta non deve condurre elettricità!

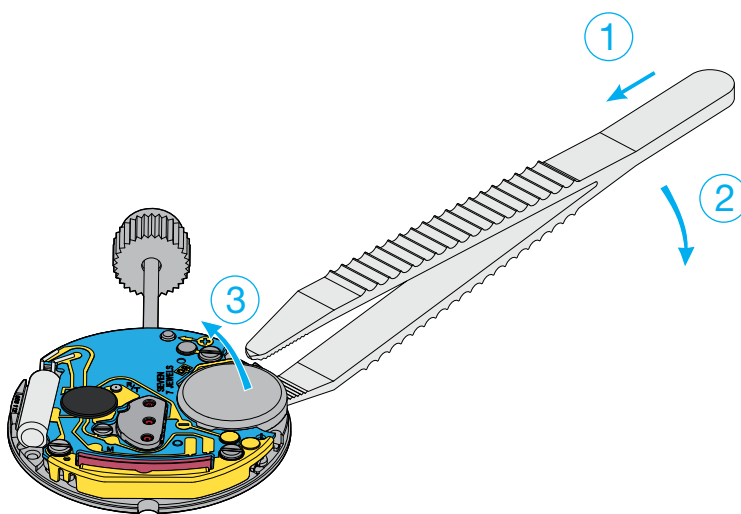

Extracting the stem

The handsetting stem must be pushed back to position 1 (neutral) before pressing on the point lying on the right sider of the setting lever.

Extracción de la tija de puesta en hora

Antes de pulsar el punto a la derecha del tirete, es obligatorio empujar la tija de puesta en hora en posición 1 (neutral).

Estrazione dell'albero di messa all'ora

Prima di premere il punto a destra del tireto, è obbligatorio premere l'albero di messa all'ora in posizione 1 (neutra).

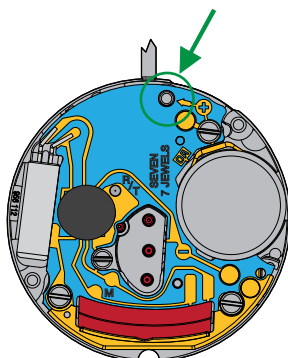



For information regarding hand fitting heights see:

Manufacturing Information

Drawing:
AIGUILLAGES
ZEIGERWERKHÖHEN
HAND FITTING HEIGHTS



Para obtener información sobre las alturas de la minutería, consulte:

Información de la producción

Plan:
AIGUILLAGES
ZEIGERWERKHÖHEN
HAND FITTING HEIGHTS



Per informazioni concernenti l'aggiustamento lancette, consultare:

Informazione di produzione

Disegno:
AIGUILLAGES
ZEIGERWERKHÖHEN
HAND FITTING HEIGHTS

This page has deliberately been left blank in case of A3 format printing.

Esta página se han dejado en blanco a propósito en caso de imprimirla en formato A3.

Questa pagina è lasciata intenzionalmente bianca in caso di stampa formato A3.

This page has deliberately been left blank in case of A3 format printing.

Esta página se han dejado en blanco a propósito en caso de imprimirla en formato A3.

Questa pagina è lasciata intenzionalmente bianca in caso di stampa formato A3.

This page has deliberately been left blank in case of A3 format printing.

Esta página se han dejado en blanco a propósito en caso de imprimirla en formato A3.

Questa pagina è lasciata intenzionalmente bianca in caso di stampa formato A3.

Modifications compared with previous document versions**Modificaciones comparadas con las versiones anteriores del documento****Modifiche comparate con le versioni precedenti del documento**

Version Versión Version	Date Fecha Data	Modification	Modificación	Modifica	Page Página Pagina
10	16.03.2015	Correction: consumption of movement	Corrección: consumo de la máquina	Correzione: consumo del movimento	16
09	27.05.2014	Adaptation variante and GTIN number	Adaptación variante y número GTIN	Adattamento variante e numero GTIN	3, 4, 6, 7, 10, 11
08	21.05.2012	New illustrations	Nuevas ilustraciones	Nuove illustrazioni	1, 4-5
		New address	Nueva dirección	Nuovo indirizzo	1, 3, 24
		Montage modifications	Modificaciones montaje	Modifiche d'assemblaggio	6-15
		New chapters	Nuevos capítulos	Nuovi capitoli	18-19
07	28.09.2010	Modifications lubrications	Modificaciones lubricaciones	Modifica lubrificazione	7
06	04.12.2009	Correction of the height over battery	Correzione della altezza sopra la batteria	Corrección de la altura sobre pila	1
05	08.09.2009	Modification lubrication	Modificación lubricación	Modifica lubrificazione	6
		New layout	Nuevo layout	Nuovo layout	1-12
		Allocation per caliber	Asignación por calibre	Ripartizione per calibro	--

All modifications reserved.

Salvo modificación.

Con riserva di ogni eventuale modifica.

This document can be found on the
Support Center Portal (SCP):

www.eta.ch

- Support Center
- Support Center Portal
- Technical Documents

Este documento se encuentran en el
Support Center Portal (SCP):

www.eta.ch

- Support Center
- Support Center Portal
- Technical Documents

Il presente documento si trovano sul
Support Center Portal (SCP):

www.eta.ch

- Support Center
- Support Center Portal
- Technical Documents



ETA^{SA}
MANUFACTURE HORLOGÈRE SUISSE
DEPUIS 1793

SC PRODUCT COMMUNICATION

Bahnhofstrasse 9
2540 Grenchen
Switzerland

Phone +41 (0)32 655 71 11
Fax +41 (0)32 655 71 74

contact@eta.ch
www.eta.ch