

Watch Movement Specification and Drawing

CALENDAR

Cal. AL32A

Movement Size

10 1/2'''

Casing Diameter

Ø 23.3mm

Height

4.15mm

Battery Life

2 years

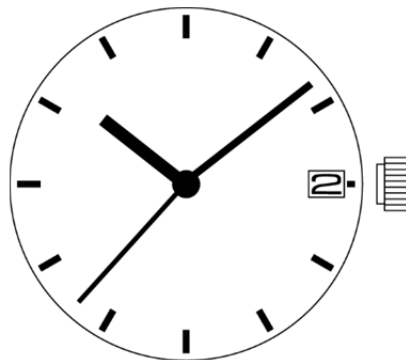

Date: 20/Oct./'14

Cal. AL32A

Items	Rev.	Page
Specifications	03	1
Appearance	01	2
Casing	02	3
Hand fitting	01	4
Hand setting stem	03	5
Dial-01	01	6-01
Dial-02	01	6-02
Dial-03	01	6-03
Dial-04	01	6-04
Casing ring	02	7

Analog Quartz 10 1/2" Calendar Series Movement / Three Hands(H/M/S) with Calendar

1. MOVEMENT DIMENSIONS

Outside diameter	ϕ 23.70mm × 22.00mm(3-9H) × 22.60mm(12-6H)
Casing diameter	ϕ 23.00mm
Total height	4.15mm (including battery)

2. TIME STANDARD

Type of quartz oscillator	Tuning fork
Frequency of quartz oscillator	32,768 Hz
Accuracy	±20 seconds per month (on wrist)
Operating temperature range	-5°C to +50°C
Regulation device	Nil (Pre-adjusted)

3. INDICATOR / FUNCTIONS

3 Hands	Hour / Minute / Second						
Calendar	Instant setting device for date calendar						
Reset switch							
Setting mechanism	<table> <tr> <td>Crown at normal position</td> <td>: Free</td> </tr> <tr> <td>Crown pulled out 1st click</td> <td>: Instant date change</td> </tr> <tr> <td>Crown pulled out 2nd click</td> <td>: Time setting / Reset</td> </tr> </table>	Crown at normal position	: Free	Crown pulled out 1st click	: Instant date change	Crown pulled out 2nd click	: Time setting / Reset
Crown at normal position	: Free						
Crown pulled out 1st click	: Instant date change						
Crown pulled out 2nd click	: Time setting / Reset						

4. FEATURES

Jewels	0 Jewels						
Anti-magnetism	Over 1600A/m (Direct current magnetic field)						
Maximum unbalance of hands	<table> <tr> <td>Second hand</td> <td>: 0.06 μ N·m</td> </tr> <tr> <td>Minute hand</td> <td>: 0.6 μ N·m</td> </tr> <tr> <td>Hour hand</td> <td>: 0.5 μ N·m</td> </tr> </table>	Second hand	: 0.06 μ N·m	Minute hand	: 0.6 μ N·m	Hour hand	: 0.5 μ N·m
Second hand	: 0.06 μ N·m						
Minute hand	: 0.6 μ N·m						
Hour hand	: 0.5 μ N·m						

5. BATTERY

Type / Size	Silver oxide battery / ϕ 6.8mm × t 2.6mm
Recommended battery	SR626SW
Nominal voltage	1.55 V
Battery life	Approx. 2 years
Driving current consumption	Approx. 1.5 μ A
Operation stopping voltage	1.1 V

6. SEPARATED PARTS (Parts code)

Hand setting stem	0351177 or 0351578
Battery	SR626SW

7. TEST OF ACCURACY

Equipment to be used	SEIKO quartz tester QT-99, Greiner quartz timer-C , Witschi Q-tester 4000
Duration of measurement	10 seconds
Microphone to be used	Electromagnetic detection type

All specifications are subject to change without notice.

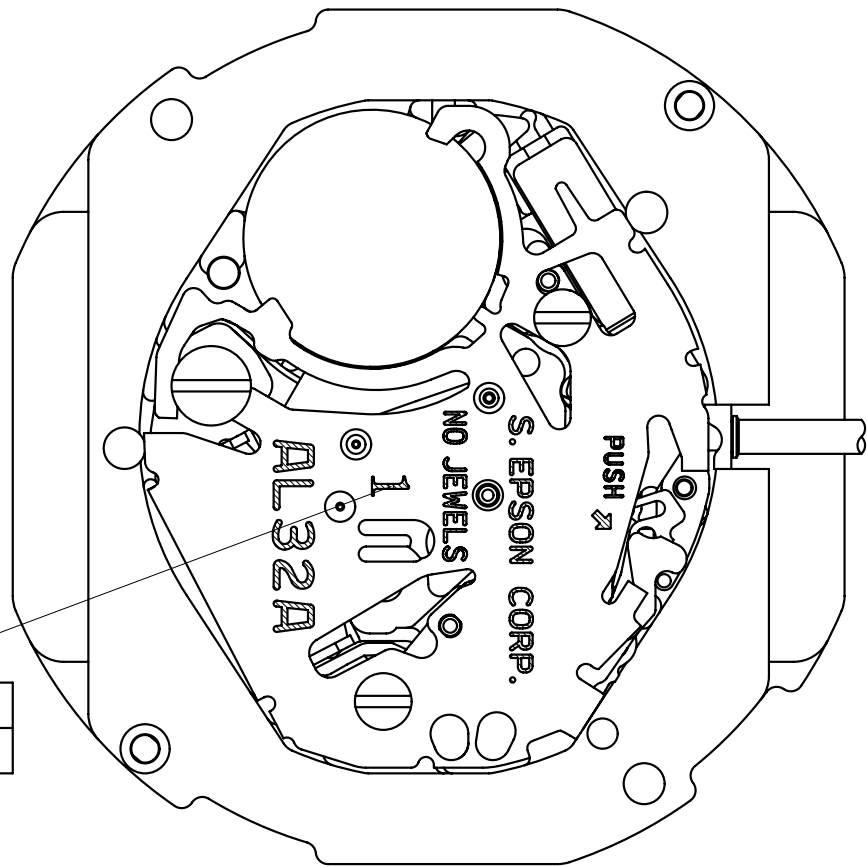

Hands type

	Mark
Type S (1)	1

Dial leg hole B

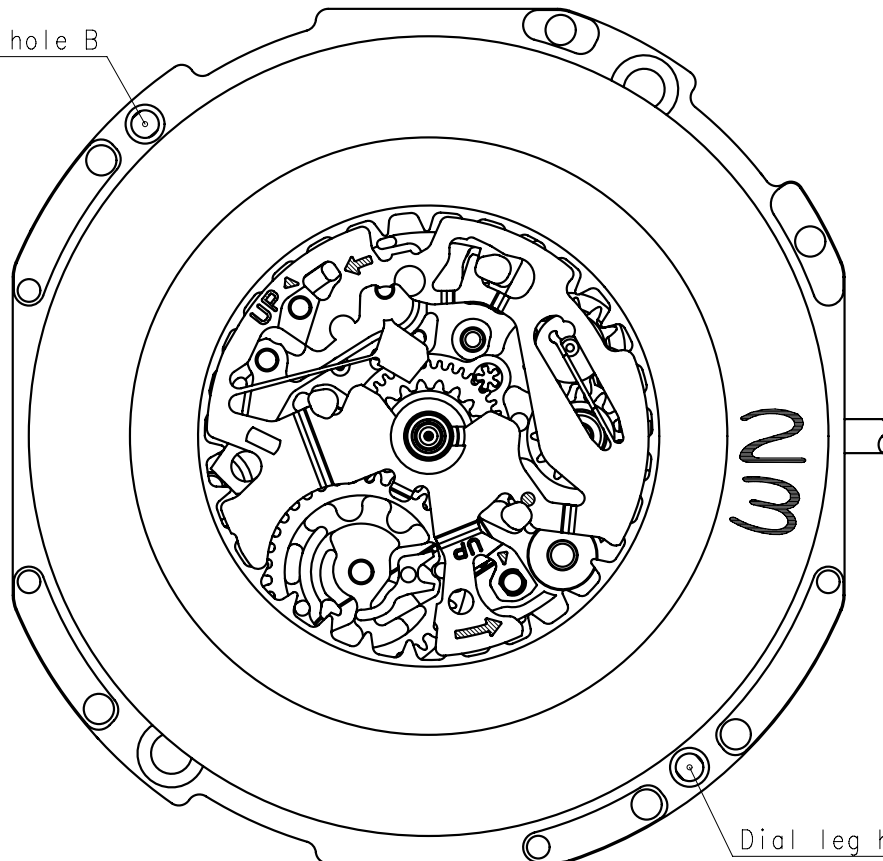

Dial leg hole A

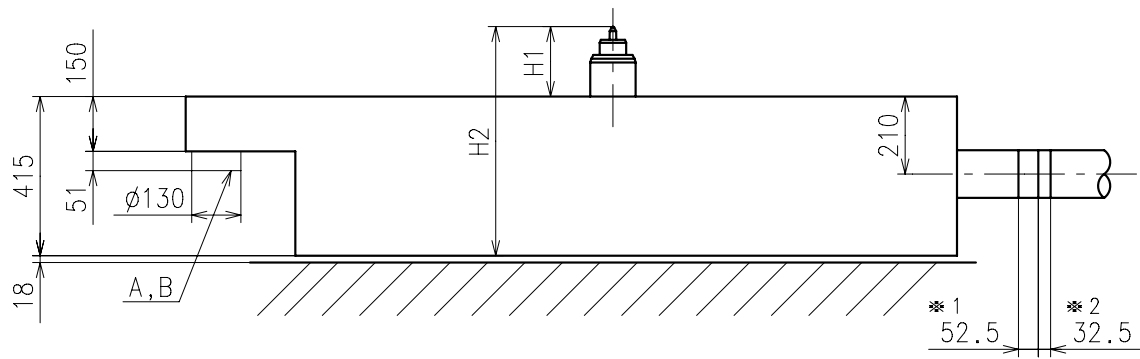

Center post		Type S (1) AL32A
Maximum height from dial support	H1	185
Total height including movement	H2	600

*1:First pullout stroke

*2:Second pullout stroke

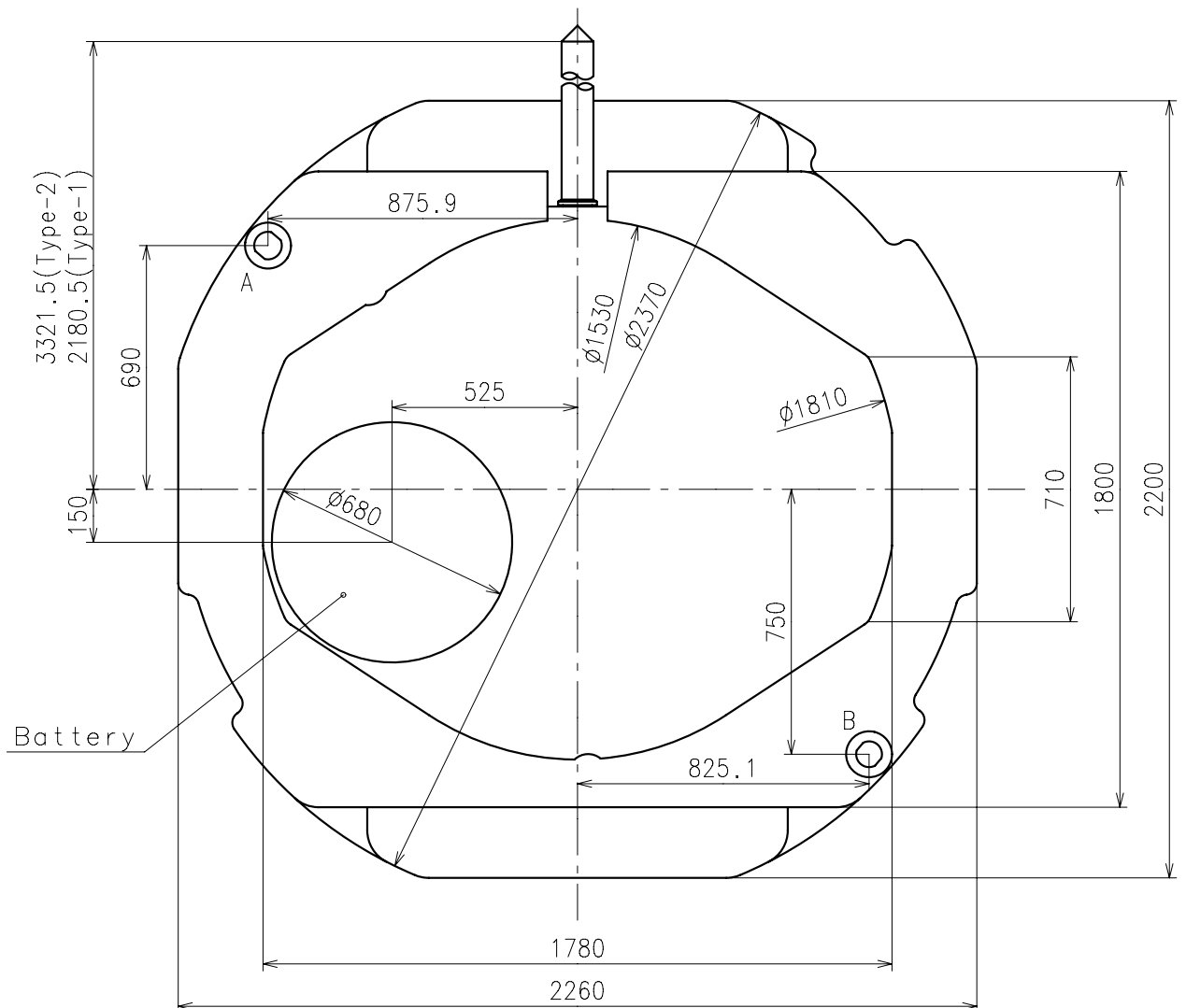

- * Second hand unbalance $\leq 0.06\mu N \cdot m$ ($6\mu g \cdot m$)
- * Minute hand unbalance $\leq 0.6\mu N \cdot m$ ($60\mu g \cdot m$)
- * Hour hand unbalance $\leq 0.5\mu N \cdot m$ ($50\mu g \cdot m$)

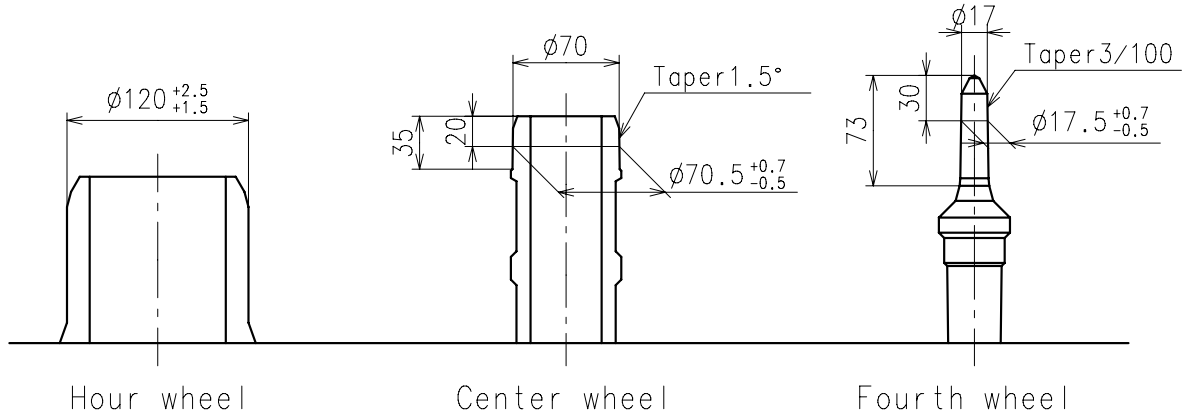

	Parts No.		
	Hour wheel	Center wheel	Fourth wheel
Type S (1) AL32A	0271517	0221565	0241527

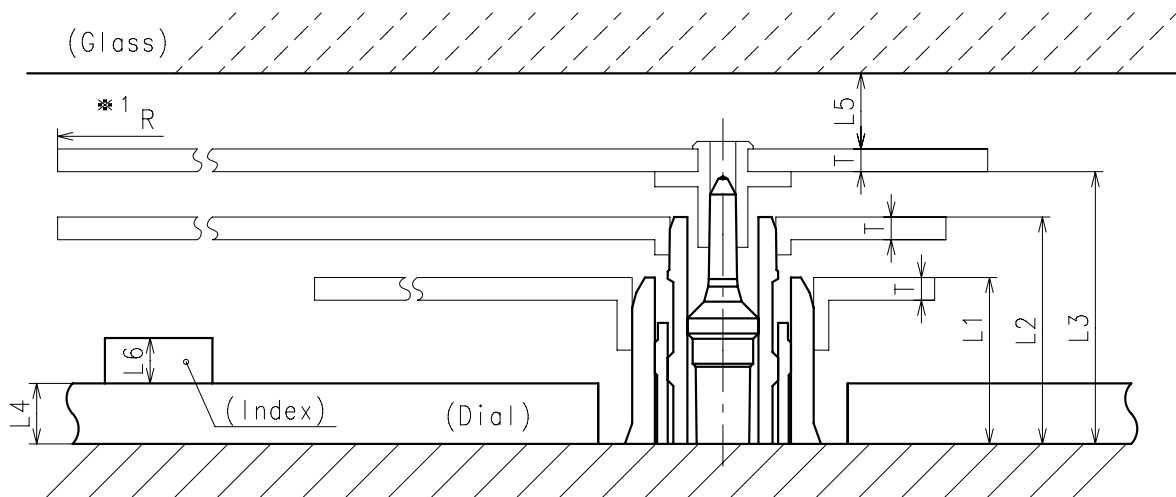

	L1	L2	L3	L4	L5	L6	T	*1 R
Type S (1) AL32A	110	150	180	40	MIN: 50	MAX: 30	15	MAX: 1250

*1: It is the size taken into consideration for hands attachment.
Please observe some standard value specified in unbalance when using long hands.

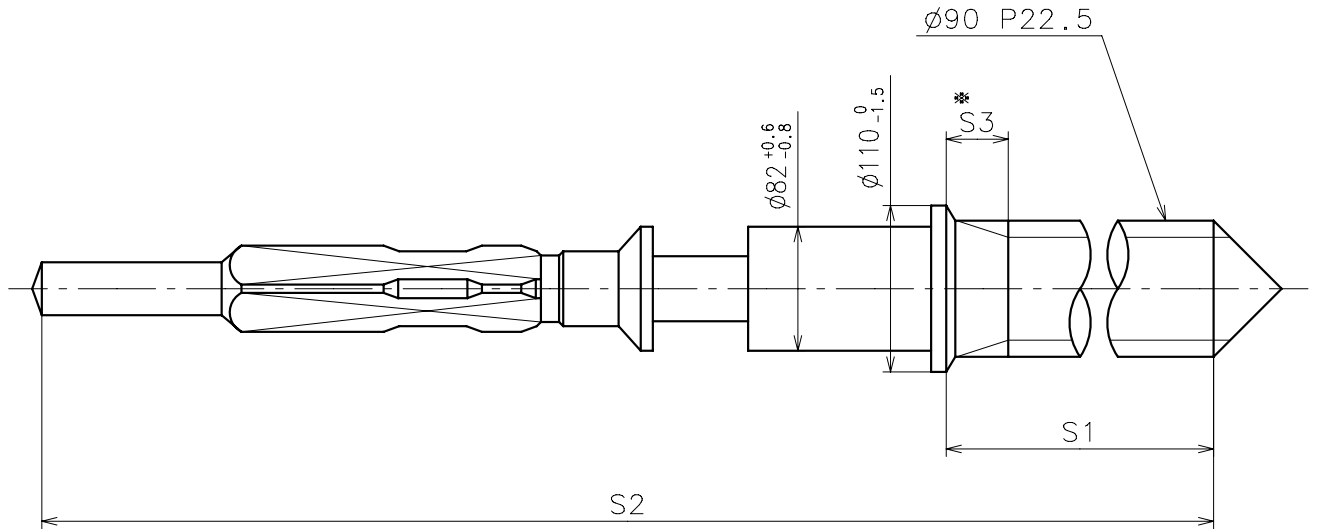

※ Not threaded

	Part No.	S1	S2	※ S3
Type-1 (Standard)	0351177	1366	1964	60
Type-2	0351578	2507	3105	650

Material : Steel

Hardness : Vickers 600±50

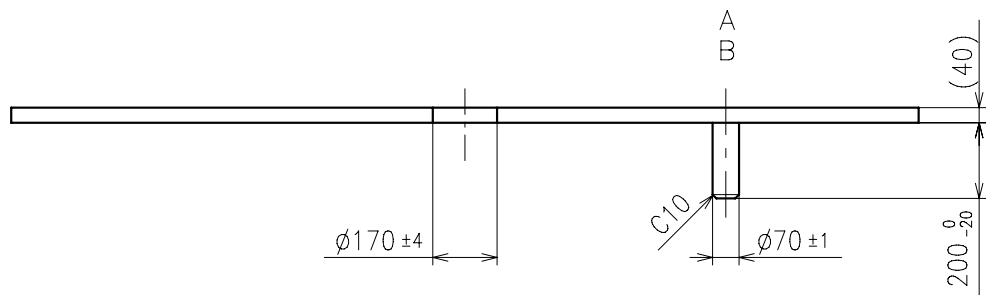
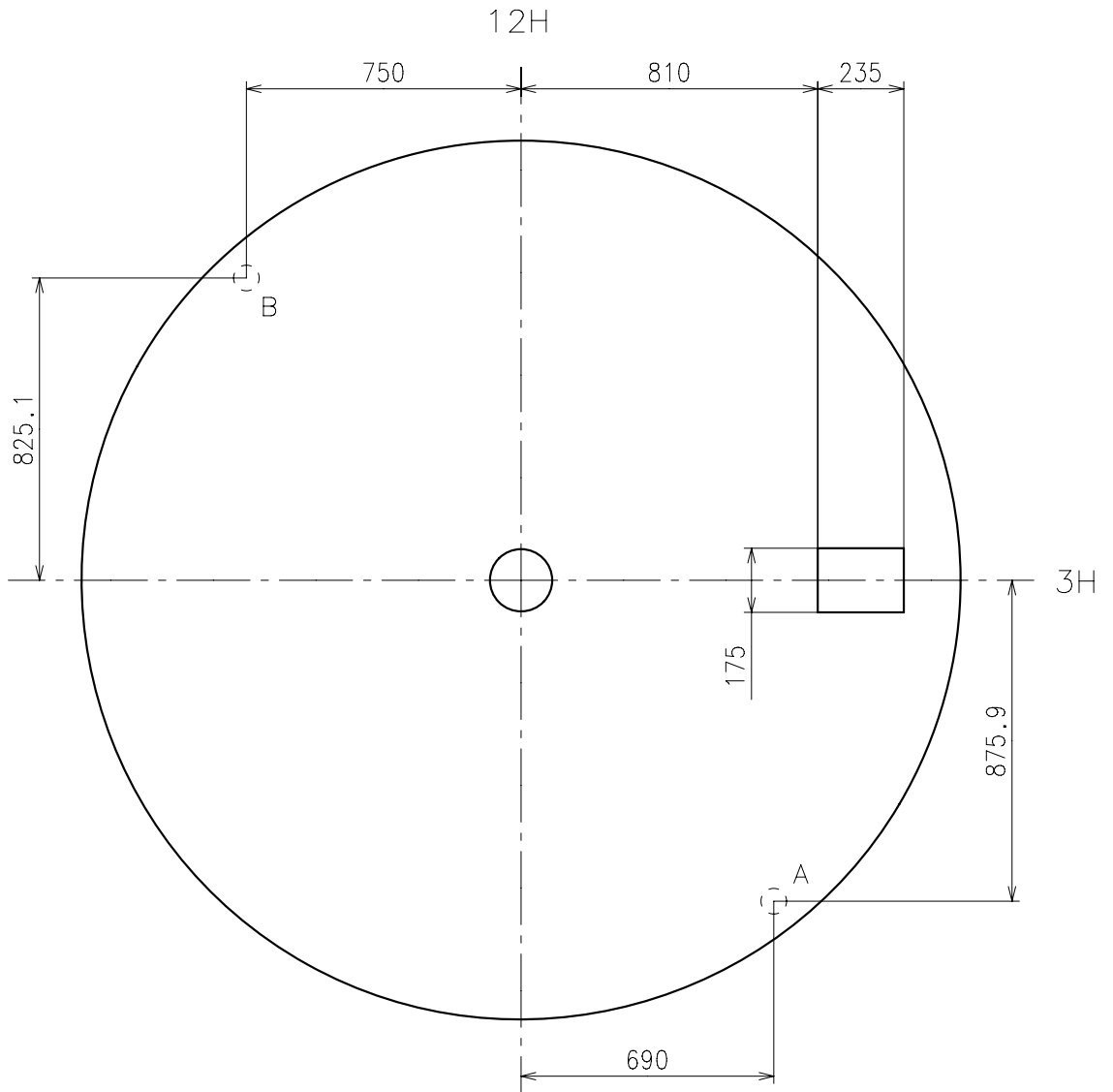

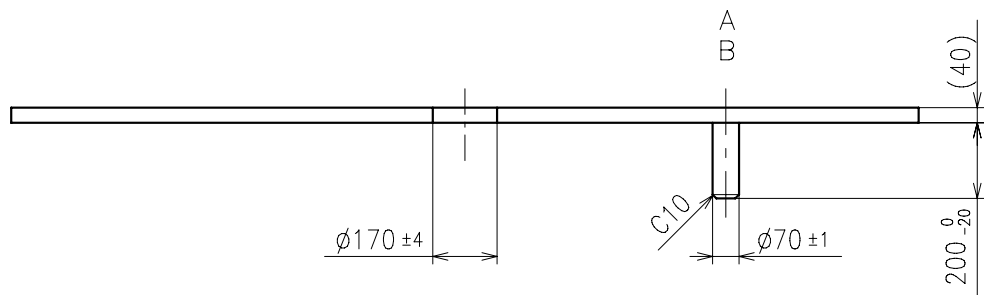
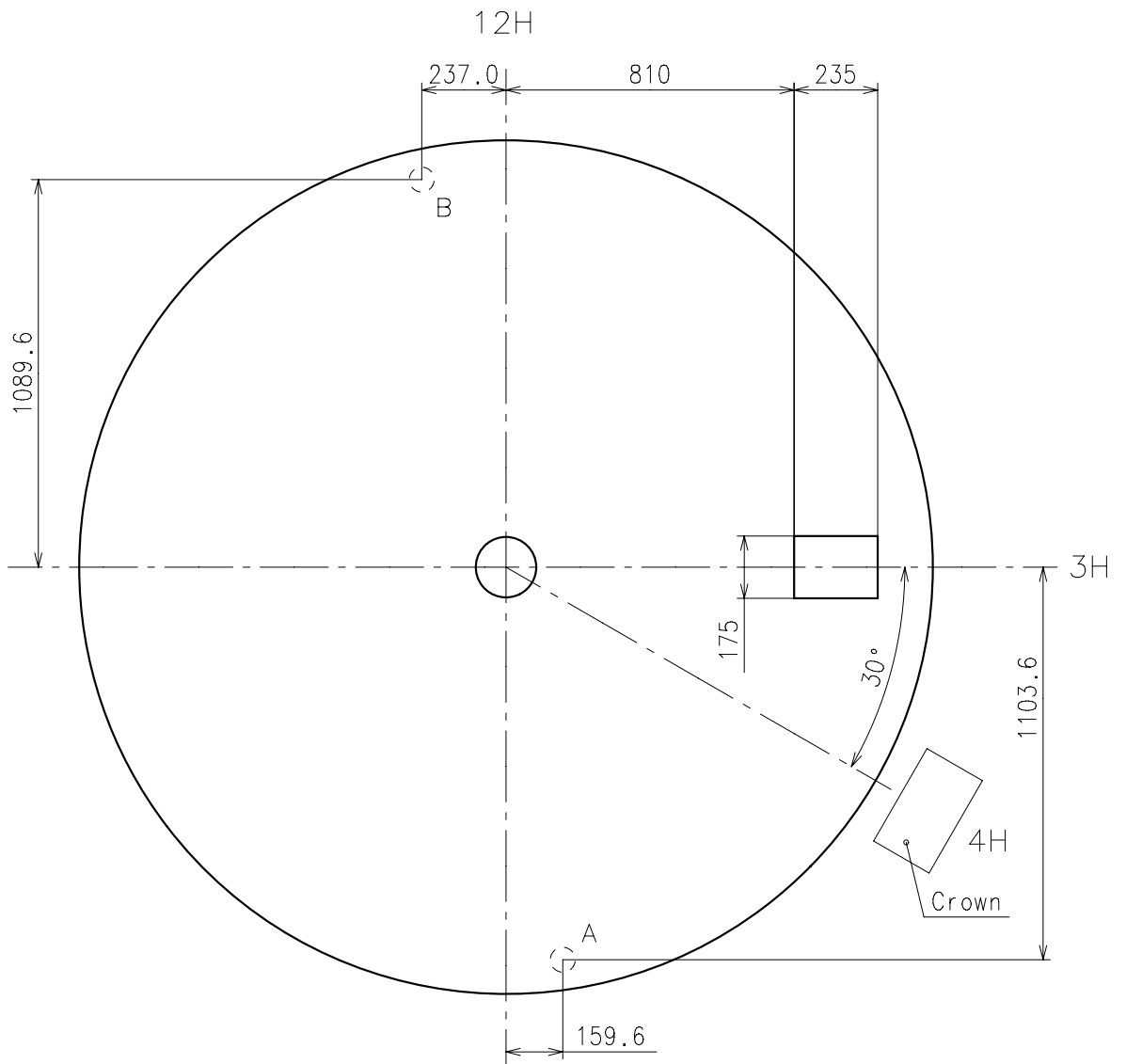

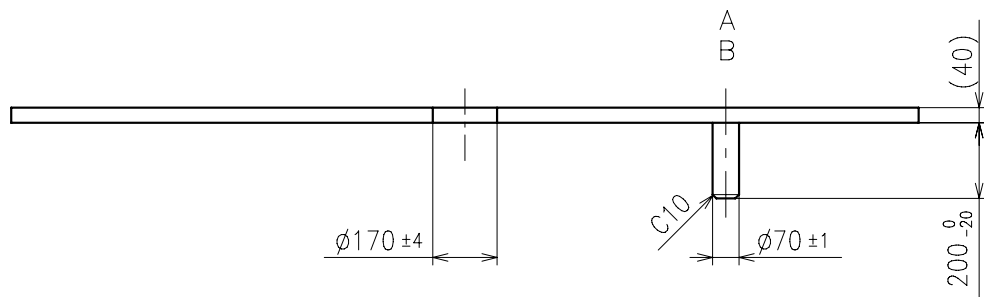
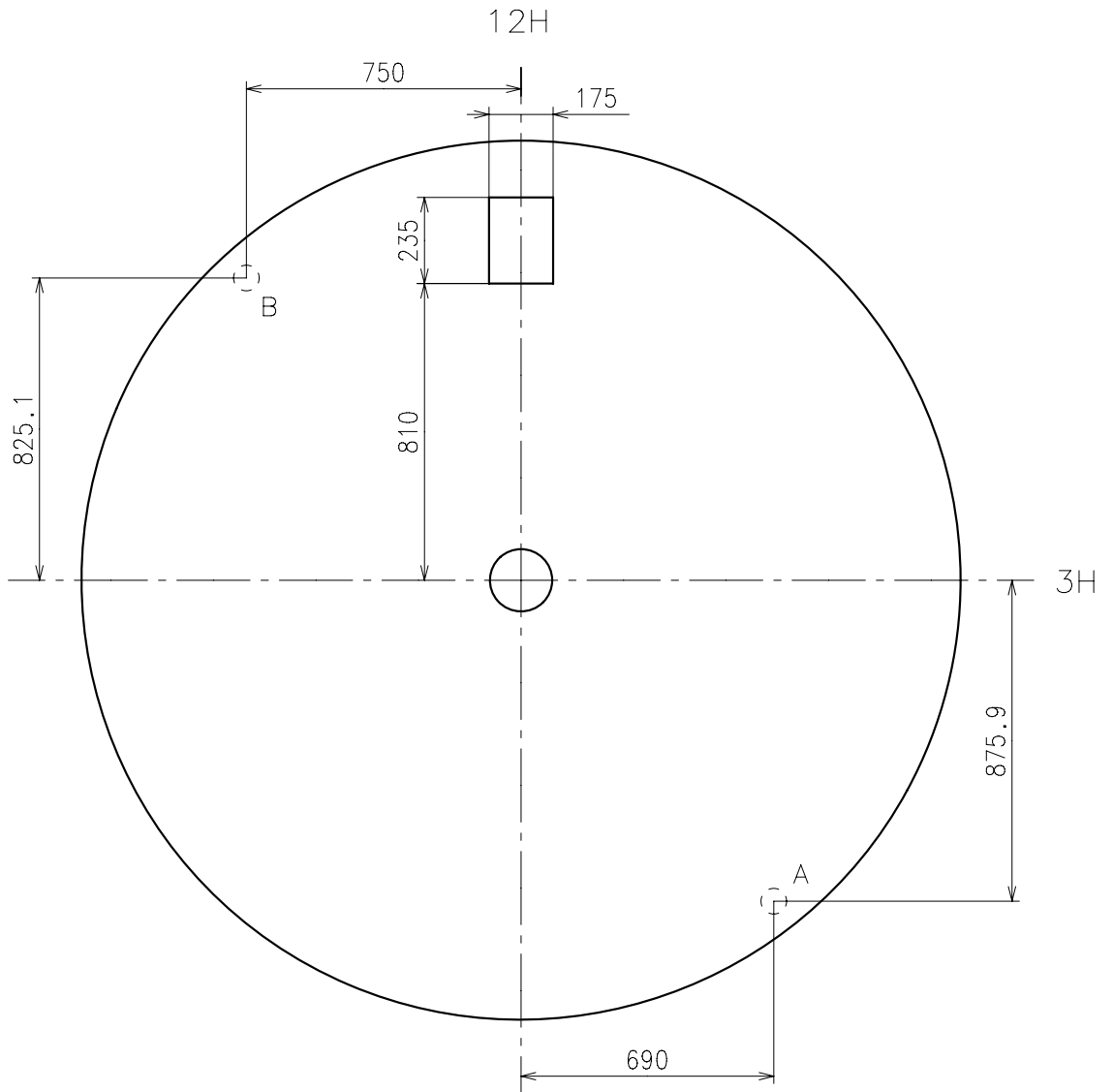

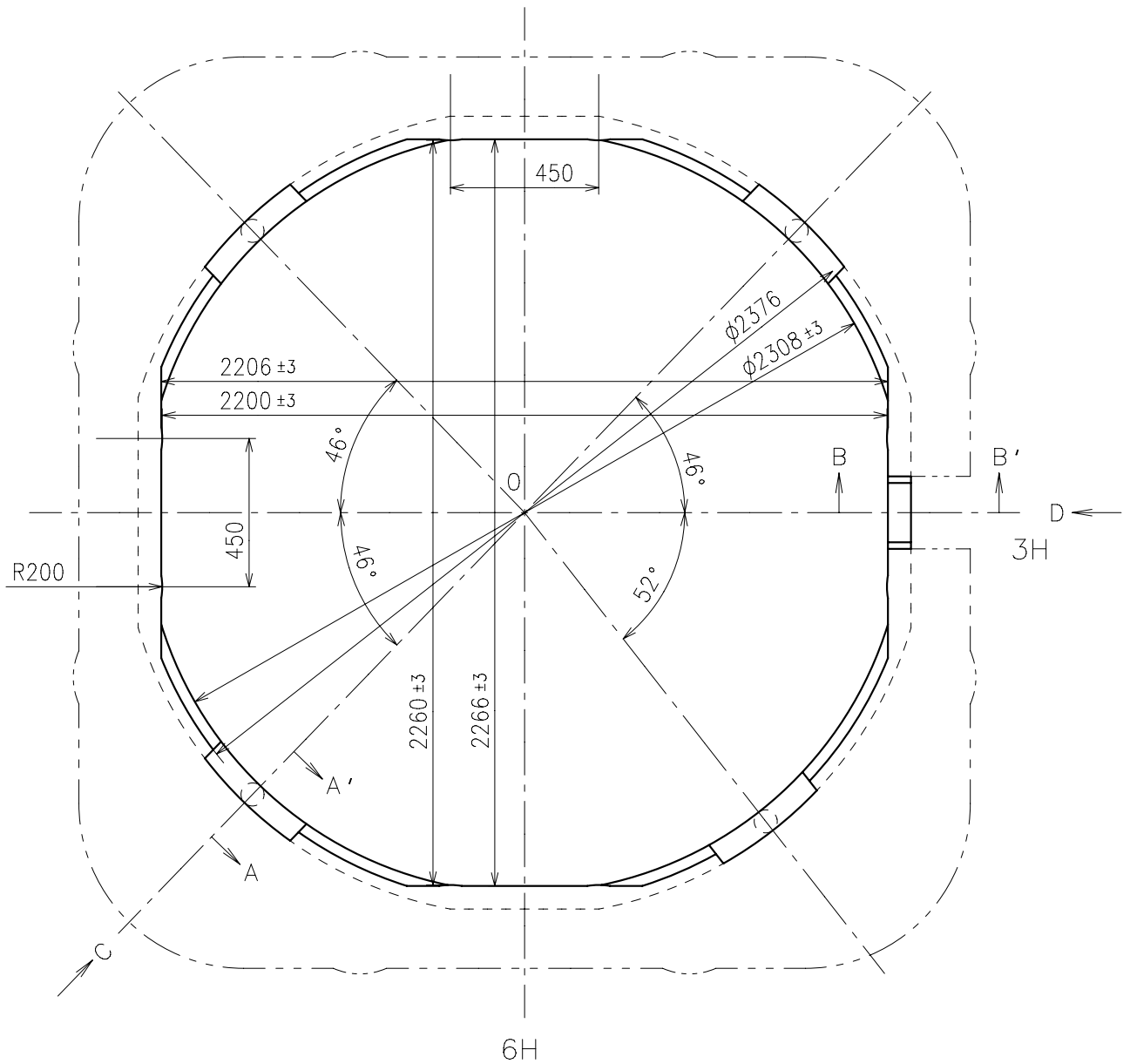

C view

A-A' section

B-B' section

D view

