

**TECHNICAL GUIDE  
&  
PARTS CATALOGUE**

**Cal.VD51C**

**ANALOGUE QUARTZ**

**SII Products**

## Cal.VD51C

[SPECIFICATION]

Version-01

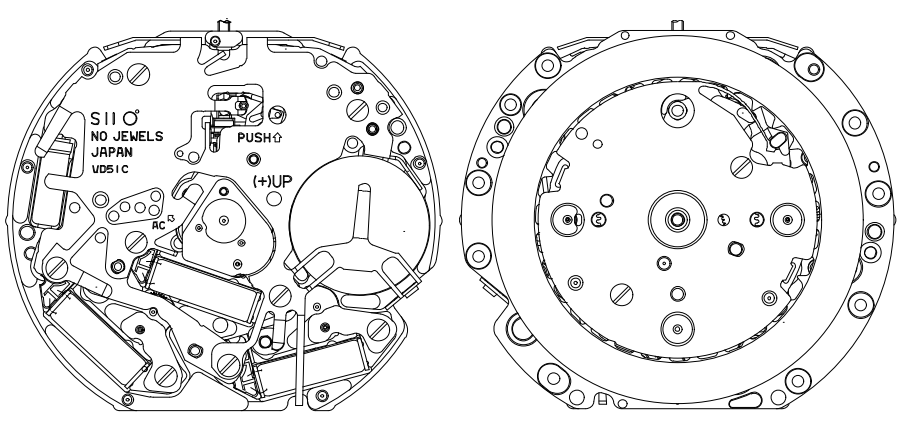
Item		Cal. No.	Cal.VD51C		
Movement					
Movement size	Outside diameter	( $\phi D$ ) $\phi 29.50 \text{ mm}$	(3H - 9H) × 26.00 mm	(12H - 6H) × —	
	Casing diameter	( $\phi D$ ) $\phi 28.80 \text{ mm}$	(3H - 9H) × —	(12H - 6H) × —	
	Total height	4.57 mm			
Time indication	3 hands ( Hour , Minute , Second ) Chronograph ( minute , 1/1 second ) Calendar				
Driving System	Two pole stepping motor Step motor 3 pieces				
Additional mechanism	Electronic circuit reset switch Second setting device [ Time ] Indicated by Hour , Minute , Second [ Stop watch ] Up to 60 minute in 1 second split time				
Antimagnetic	$\geq 1600 \text{ A/m}$				
Accuracy	Less than $\pm 20$ seconds : Monthly rate at normal temperature range				
Battery	SR920SW (SEIZAIKEN) Silver oxide battery $\phi 9.5 \times t 2.0 \text{ mm}$ Battery life is approximately 3 years				
Measuring gate by quartz tester	Use 10-second gate * Set the winding stem with crown at the normal position				
Jewels	0 Jewel				

Disassembling procedures Figs. (1) ⇒ (53)  
Reassembling procedures Figs. (53) ⇒ (1)

Lubricating : Types of oil      Oil quantity

●▶ Moebius 9010      ◊▶ Normal quantity  
■▶ Moebius 9030  
●●▶ S-6

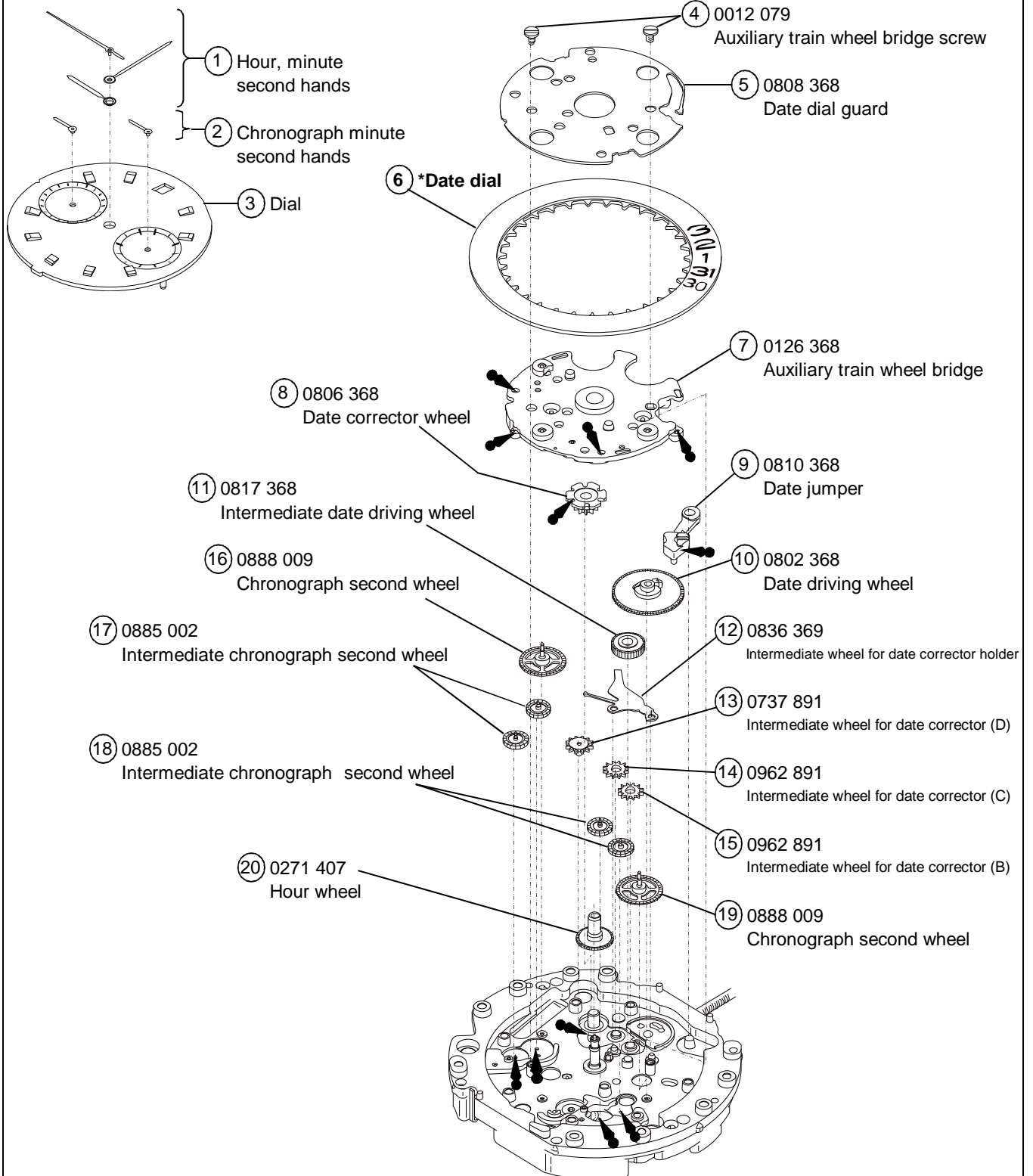

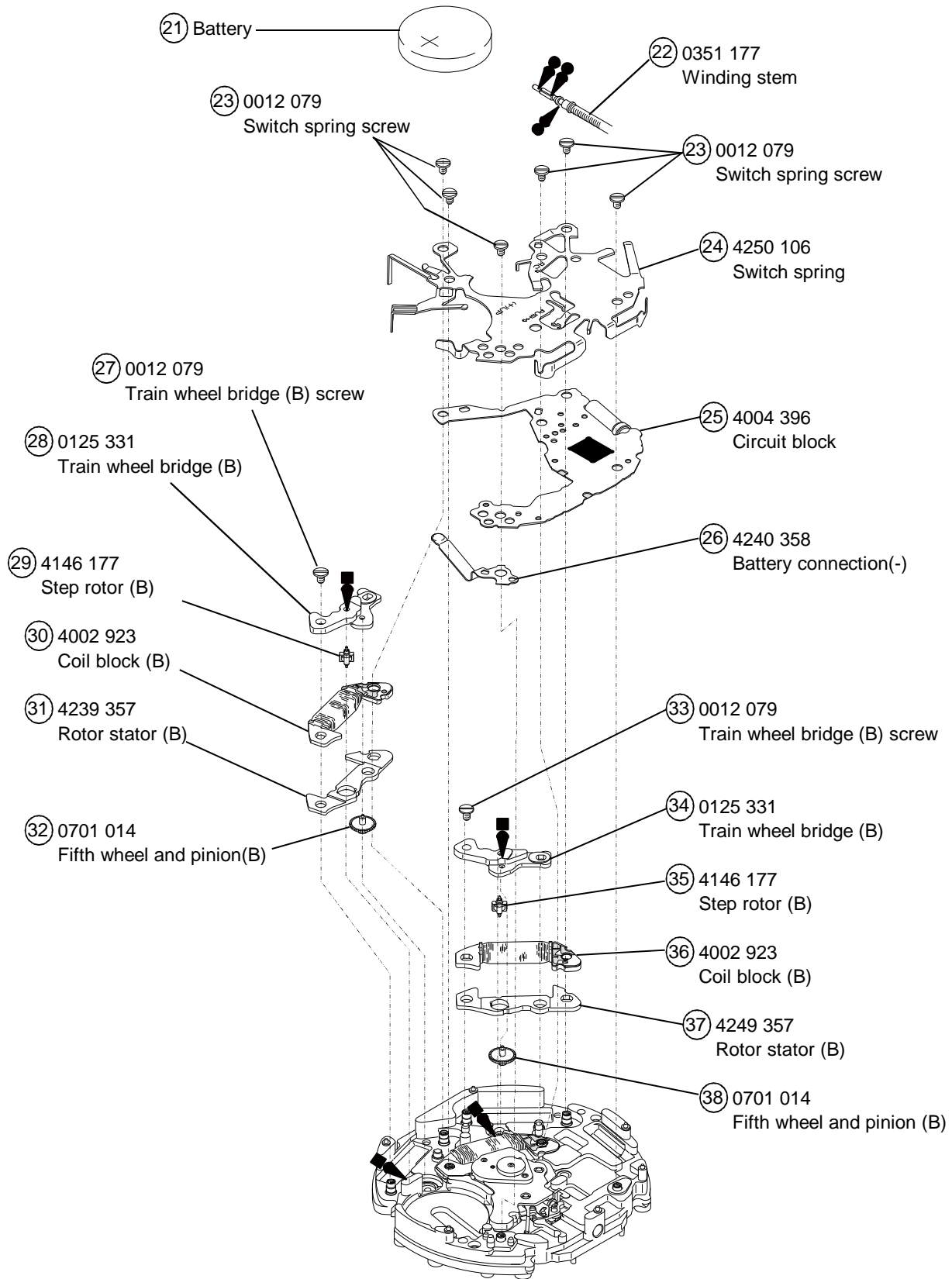

**\* All parts code are subject to change without notice.**

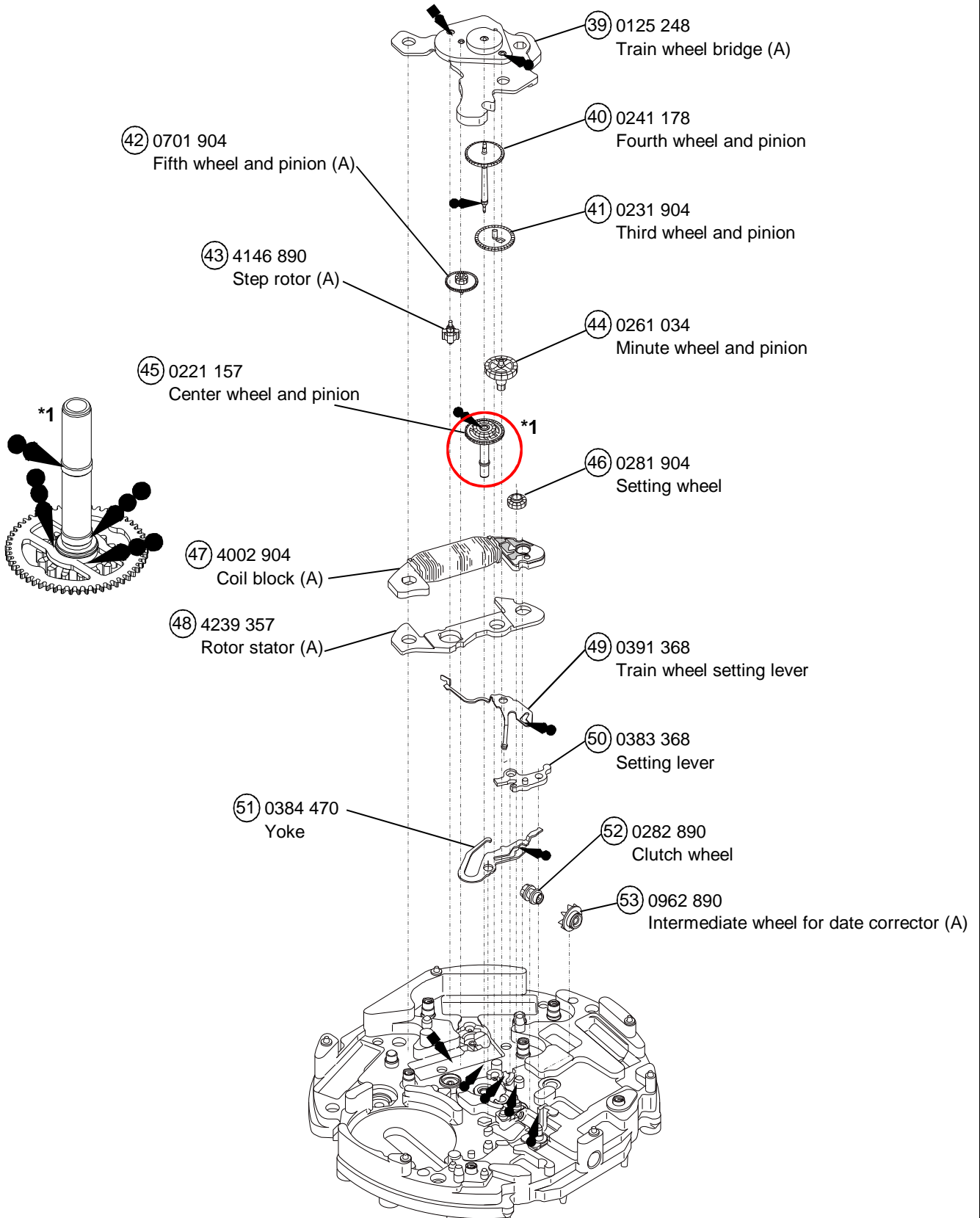

**\* All parts code are subject to change without notice.**

Remarks:

⑥ **Date dial**

Part code	Position of crown	Position of date frame	Color of figure	Color of background
0878 220	3H	3H	Black	White
0878 221	3H	3H	White	Black

\* All parts code are subject to change without notice.

•The explanation here is only for the particular point of Cal.VD51C

**1.REMARKS ON INSTALLING THE BATTERY**

1)After the battery is replaced with a new one or after the battery is reinstalled following the repairing procedures, Be sure to touch the short-circuit the AC terminal of circuit block and the switch spring with conductive tweezers to reset the circuit as illustrated at right.

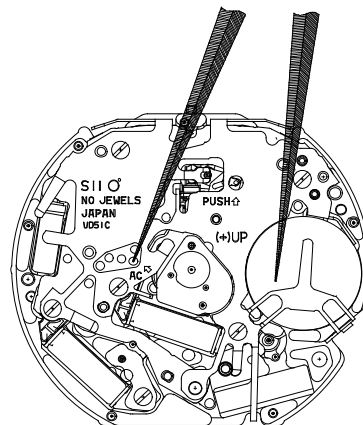

2) When the battery replaced with a new one, the time information stored in the built-in IC and the time indicated by the stopwatch hands do not correspond with each other. Reset the stopwatch hands to "0" position following the procedure below. If the stopwatch hands should move improperly, also follow the same procedure.

①Pull the crown out to the second click.

②Keep buttons "A" and "B" pressed at the same time for 2 seconds, and then, release the buttons. The stopwatch second hand move back and returned to where it was.

③Press button "A" or "B" to reset the stopwatch second and minute hands to "0" position.

\* By pressing button "A" , set the stopwatch 1/1 second hand.

\* By pressing button "B" , set the stopwatch minute hand.

④Turn the crown to set the hour, and minute hands to the desired time, and push the crown back in to the normal position.

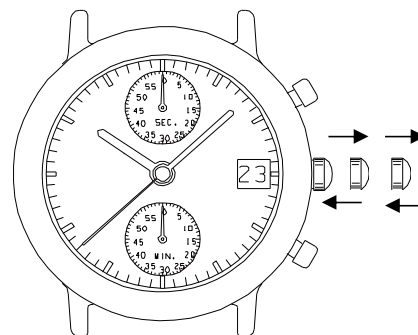

1.REMARKS ON INSTALLING THE BATTERY

(1) HAND

•How to install the hands

Place the movement directly on a flat metal plate or the like and press in the hands.

\* Install the hour , minute and second hands at the "12" o'clock position

\* Install the chrono minute and second hands at the "0" position.

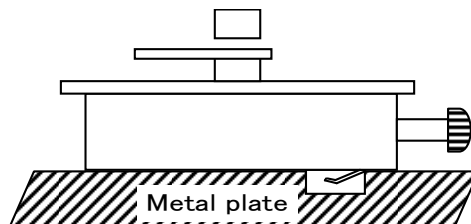

[Reference] The power of press hands

Minute & Hour hands < 5kg

Second hand < 5kg

Chrono minute & second < 3kg

(2) Battery

•How to install the battery

- ① Remove the hook of the switch spring 's battery clamp portion.
- ② Insert the battery sideways, and have the hook of the switch spring 's battery clamp portion catch the main plate.

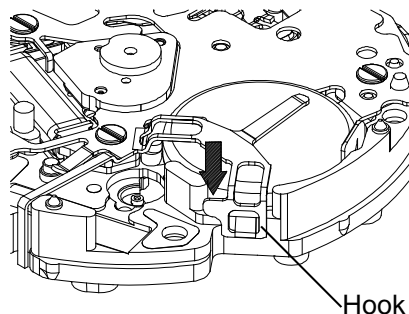

Battery clamp position

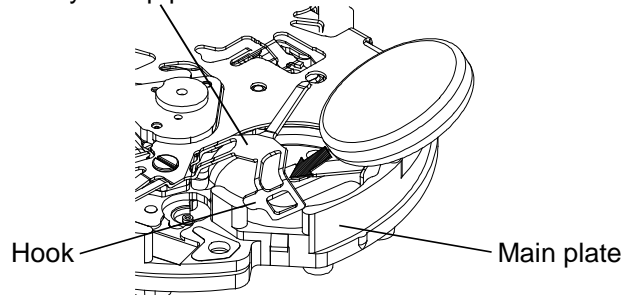

(3)Winding stem

•How to remove

While pushing the indented portion of the arrow pull out the winding stem.

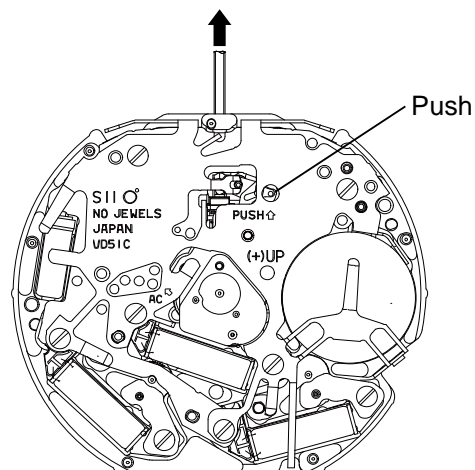

**DISPLAY AND CROWN / BUTTON OPERATION**

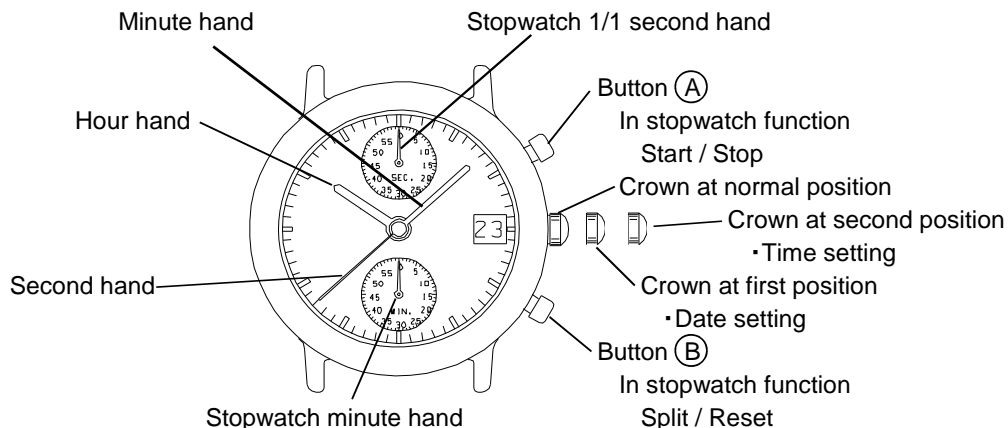

\*The measurement time is indicated by the stopwatch hands that move independently of small second hand.

**ADJUSTING THE STOPWATCH HAND POSITION**

Before setting the time , check if the stopwatch 1/1 second , minute hands are in the "0"(12 o'clock) position.

\* If the stopwatch is in use , press the button in the following order to reset it , and then , check if the hands return to "0" position.  
(for details , see "HOW TO USE THE STOPWATCH")

- \* If the stopwatch is counting : (A) → (B)
- \* If the stopwatch is stopped : (B)
- \* If the split time is displayed : (B) → (A) → (B)

•If either of the stopwatch hands are not in the "0" position , reset them following the procedure below.

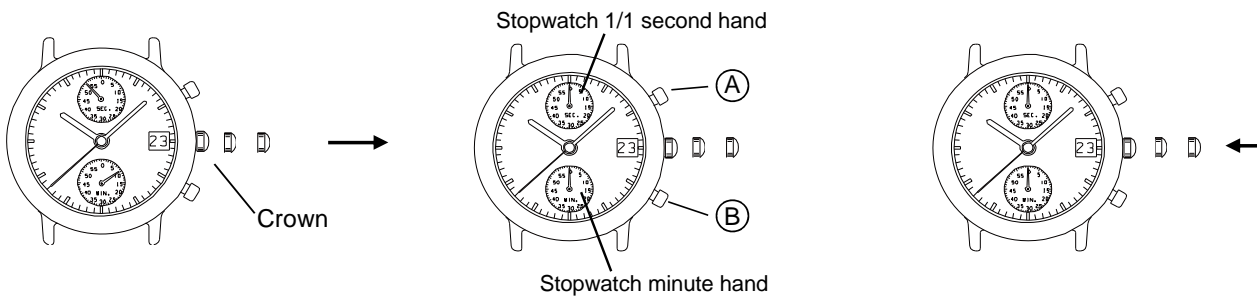

1. Put the crown out to the second click.

2. Press button A or B to reset the stopwatch 1/1second , minute hands to "0" position.  
\* By pressing button A , set the stopwatch 1/1second hand.  
\* By pressing button B , set the stopwatch minute hand.

3. Push the crown back in to the normal position.

\*The stopwatch minute hand moves correspondingly with the stopwatch second hand.  
\*The hands move quickly if the respective buttons are kept pressed.

**TIME SETTING**

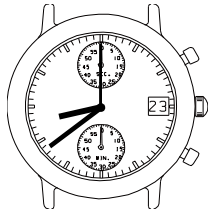

1. Pull out the crown to the first click.

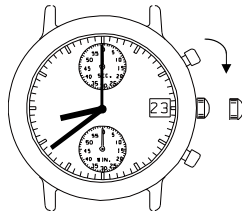

2. Turn the crown clockwise until the previous day's date appears.

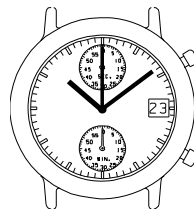

3. Pull out the crown to the second click when the second hand is at the 12 O'clock position. It will stop on the spot and advance the hour and minute hands by turning the crown. (Check that AM / PM is set correctly)

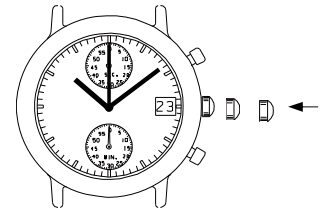

4. Push the crown back in to the normal position in accordance with a time signal.

\*When the crown is at the second click position. Do not press any button. Otherwise, the chronograph hands will move.

\*Do not set the date between 9:00 P.M. and 1:00 A.M.

Otherwise, the day may not change properly. If it is necessary to set the date during that time period, First change the time to any time outside it, set the date and then reset the correct time.

**HOW TO USE THE STOPWATCH**

- The measurement time is indicated by the stopwatch hands that move independently of the small second hands.
- The stopwatch can measure up to 12 hours in seconds.

(Standard measurement)

Ex) 100m race (Press the buttons in the following order

(A) ⇒ (A) ⇒ (B)

START

STOP  
(Finish)

RESET  
(Reset to "0:00")

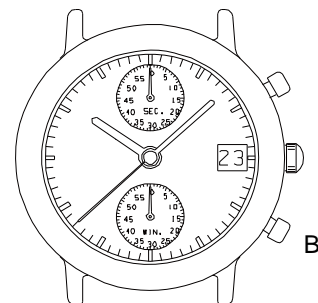
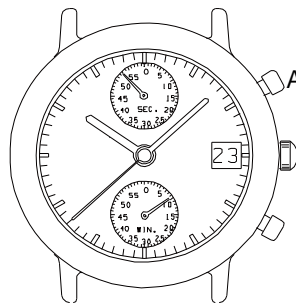
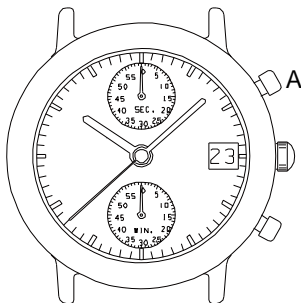

**HOW TO USE THE STOPWATCH**

(Accumulated elapsed time measurement)

Ex.) Basketball game (Press the buttons in the following order (A) ⇒ (A) / (A) ⇒ .. ⇒ (A) ⇒ (B) )

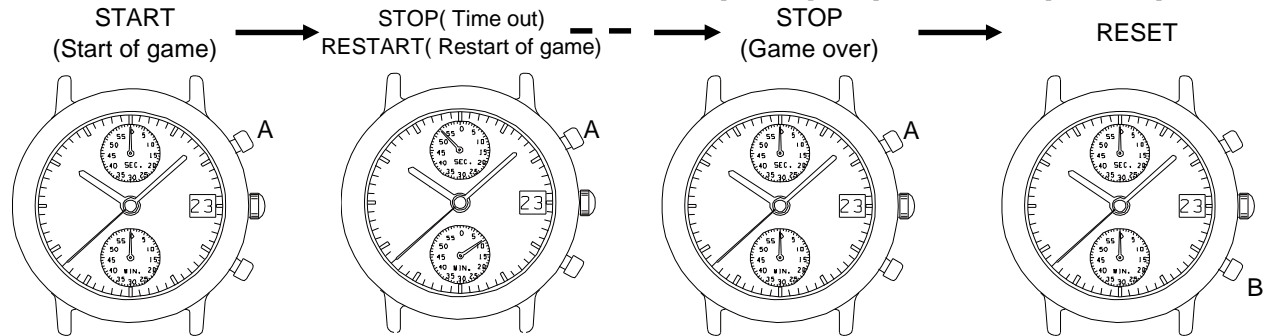

\*Restart and stop of the stopwatch can be repeated as many times as necessary by pressing button A.

(Split time measurement)

Ex.) 5,000m race (Press the buttons in the following order (A) ⇒ (B) / (B) ⇒ .. ⇒ (A) ⇒ (B) )

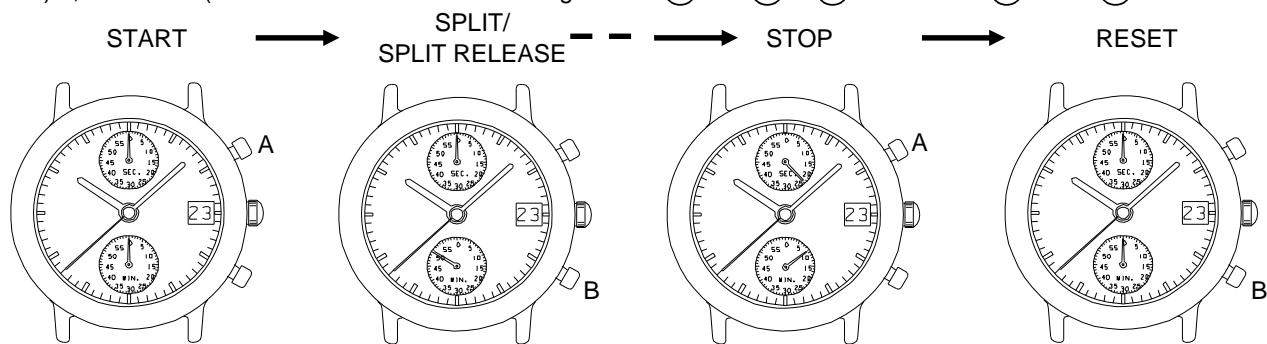

\*Measurement and release of the split time can be repeated as many times as necessary by pressing button B.